

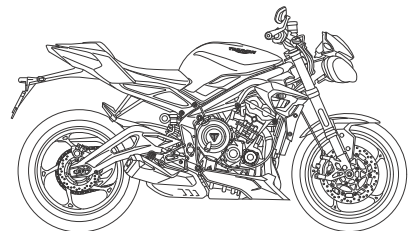

## Street Triple S (36.6 cu in (600 cc)), Street Triple R, Street Triple R (LRH) and Street Triple RS

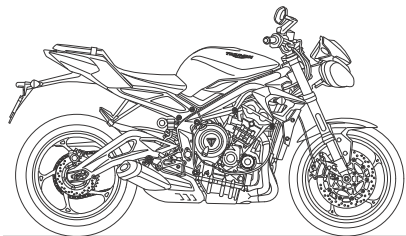

This handbook contains information on the Triumph Street Triple S (36.6 cu in (600 cc)), Street Triple R, Street Triple R (LRH) and Street Triple RS motorcycles. Always store this Owner's Handbook with the motorcycle and refer to it for information whenever necessary.

The information contained in this publication is based on the latest information available at the time of printing. Triumph reserves the right to make changes at any time without prior notice, or obligation.

Not to be reproduced wholly or in part without the written permission of Triumph Motorcycles America Limited. Este Manual del propietario está disponible en español.

© Copyright 06.2023 Triumph Motorcycles America Limited.

Publication part number 3850186\_2-US-EN issue 2

This handbook contains a number of different sections. The table of contents below will help you find the beginning of each section where, in the case of the major sections, a further table of contents will help you find the specific subject required.

- 03** FOREWORD
- 07** SAFETY FIRST
- 16** WARNING LABELS
- 18** PARTS IDENTIFICATION
- 23** SERIAL NUMBERS
- 25** GENERAL INFORMATION
- 121** HOW TO RIDE THE MOTORCYCLE
- 133** ACCESSORIES, LOADING AND PASSENGERS
- 139** MAINTENANCE AND ADJUSTMENT
- 197** CLEANING AND STORAGE
- 207** WARRANTY
- 221** SPECIFICATIONS
- 227** SPECIFICATIONS
- 233** SPECIFICATIONS
- 239** INDEX
- 244** APPROVAL INFORMATION

## Dangers, Warnings, Cautions and Notices

Particularly important information is presented in the following form:

### **DANGER**

This danger symbol identifies special instructions or procedures which, if not correctly followed, will result in serious injury, or death.

### **WARNING**

This warning symbol identifies special instructions or procedures which, if not correctly followed, could result in serious injury, or death.

### **CAUTION**

This caution symbol identifies special instructions or procedures which, if not strictly observed, could result in minor or moderate injury.

### **NOTICE**

This notice symbol indicates points of particular interest for more efficient and convenient operation.

## Warning Labels



At certain areas of the motorcycle, the symbol (above) can be seen. The symbol means **CAUTION: REFER TO THE HANDBOOK** and will be followed by a pictorial representation of the subject concerned and/or text.

Never attempt to ride the motorcycle or make any adjustments without reference to the relevant instructions contained in this handbook.

For the location of all labels showing this symbol, see the Warning Label Locations section of this Owner's Handbook. Where necessary, this symbol will also appear on the pages containing the relevant information.

## Street Triple R - Low Ride Height (LRH) Models

Unless stated otherwise, the information, instructions, and specifications for the Street Triple R - LRH model is identical to those detailed in this Owner's Handbook for the Street Triple R standard ride height model.

## Maintenance

To ensure a long, safe, and trouble-free life for your motorcycle, maintenance should only be carried out by a competent person with the specialist knowledge and technical understanding of motorcycles, such as an authorized Triumph dealer.

An authorized Triumph dealer will have the necessary knowledge, equipment, and skills to maintain your Triumph motorcycle correctly.

To locate your nearest authorized Triumph dealer, visit the Triumph web site at [www.triumph.co.uk](http://www.triumph.co.uk) or telephone the authorized distributor in your country. Their address is given in the service record book that accompanies this handbook.

## Noise Control System

Tampering with the noise control system is prohibited.

Owners are warned that the law may prohibit:

- ▼ The removal or rendering inoperative by any person other than for purposes of maintenance, repair or replacement, of any device or element of design incorporated into any new vehicle for the purpose of noise control prior to its sale or delivery to the ultimate purchaser or while it is in use and,
- ▼ The use of the vehicle after such device or element of design has been removed or rendered inoperative by any person.

Among those acts presumed to constitute tampering are the acts listed below:

- ▼ Removal of, or puncturing the muffler, baffles, header pipes or any other component which conducts exhaust gases.
- ▼ Removal of, or puncturing of any part of the intake system.
- ▼ Lack of proper maintenance.
- ▼ Replacing any moving parts of the vehicle, or parts of the exhaust or intake system, with parts other than those specified by the manufacturer.

## Owner's Handbook

### WARNING

This Owner's Handbook, and all other instructions that are supplied with your motorcycle, should be considered a permanent part of your motorcycle and should remain with it even if your motorcycle is subsequently sold.

All riders must read this Owner's Handbook and all other instructions which are supplied with your motorcycle, before riding, in order to become thoroughly familiar with the correct operation of your motorcycle's controls, its features, capabilities and limitations.

Do not lend your motorcycle to others as riding when not familiar with your motorcycle's controls, features, capabilities and limitations may lead to loss of motorcycle control which could result in serious injury or death.

Thank you for choosing a Triumph motorcycle. This motorcycle is the product of Triumph's use of proven engineering, exhaustive testing, and continuous striving for superior reliability, safety and performance.

Please read this Owner's Handbook before riding in order to become thoroughly familiar with the correct operation of your motorcycle's controls, its features, capabilities and limitations.

This Owner's Handbook includes safe riding tips, but does not contain all the techniques and skills necessary to ride a motorcycle safely.

Triumph strongly recommends that all riders undertake the necessary training to ensure safe operation of this motorcycle.

This Owner's Handbook is available from your local dealer in:

- ▼ English
- ▼ US English
- ▼ Arabic
- ▼ Chinese
- ▼ Dutch
- ▼ French
- ▼ German
- ▼ Italian
- ▼ Japanese
- ▼ Portuguese
- ▼ Spanish
- ▼ Swedish
- ▼ Thai
- ▼ Finnish (available online from [www.triumphmotorcycles.com](http://www.triumphmotorcycles.com)).

The languages available for this Owner's Handbook are dependent on the specific motorcycle model and country.

## Talk to Triumph

Our relationship with you does not end with the purchase of your Triumph. Your feedback on the buying and ownership experience is very important in helping us develop our products and services for you.

Please help us by ensuring your authorized Triumph dealership has your email address and registers this with us. You will then receive an online customer satisfaction survey invitation to your email address where you can give us this feedback.

Your Triumph Team.

This page intentionally left blank

## Table of Contents

The Motorcycle.....	08
Fuel and Exhaust Fumes .....	09
Helmet and Clothing .....	10
Parking .....	11
Parts and Accessories.....	11
Maintenance and Equipment.....	12
Riding .....	13
Handlebars and Footrests.....	15

# SAFETY FIRST

## The Motorcycle

### WARNING

This motorcycle is designed for on-road use only.

Do not ride this motorcycle off-road.

Off-road operation may lead to loss of motorcycle control which could result in serious injury or death.

### WARNING

This motorcycle is not designed to tow a trailer or be equipped with a sidecar.

Mounting a sidecar and/or a trailer may affect the handling, stability or other aspect of the motorcycle operation.

Failure to follow the advice above may lead to loss of motorcycle control which could result in serious injury or death.

### WARNING

#### Street Triple - Low Ride Height (LRH) Models

The Street Triple R - LRH motorcycles is equipped with lowered suspension and has reduced ground clearance.

As a result, the cornering banking angles that can be achieved by the Street Triple R - LRH are reduced, when compared with the standard ride height Street Triple R model.

When riding, bear in mind that your motorcycle's ground clearance is limited. Operate your motorcycle in an area free from traffic to gain familiarity with the motorcycle's ground clearance and bank angle limitations.

Banking to an unsafe angle or unexpected contact with the ground may cause instability, loss of motorcycle control which could result in serious injury or death.

### WARNING

This motorcycle is designed for use as a two-wheeled vehicle capable of carrying a rider and up to one passenger (subject to a passenger seat and footrests being installed).

The total weight of the rider, and any passenger, accessories and luggage must not exceed the maximum load limit as specified in the Specifications section.

Failure to follow the advice above may lead to loss of motorcycle control which could result in serious injury or death.



**⚠ WARNING**

This motorcycle is equipped with a catalytic converter below the engine, which along with the exhaust system reaches a very high temperature during engine operation.

Flammable materials such as grass, hay/straw, leaves, clothing and luggage etc. could ignite if allowed to come into contact with any part of the exhaust system and catalytic converter.

Always make sure flammable materials are not allowed to contact the exhaust system or catalytic converter.

Failure follow the advice above may cause a fire which could result in serious injury or death.

**Fuel and Exhaust Fumes****⚠ DANGER**

Never start the engine or run the engine in a confined area.

Always operate the motorcycle in the open air or in an area with adequate ventilation.

Exhaust fumes are poisonous and will cause loss of consciousness and death within a short period of time.

**⚠ WARNING**

**GASOLINE IS HIGHLY FLAMMABLE:**

- Always turn off the engine when refueling.
- Pay full attention and remain alert while refueling.
- Do not refuel or open the fuel filler cap while smoking or in the vicinity of any open (naked) flame.
- Take care not to spill any gasoline on the engine, exhaust pipes or mufflers when refueling.
- If gas is swallowed, inhaled or allowed to get into the eyes, seek immediate medical attention.
- Spillage on the skin should be immediately washed off with soap and water and clothing contaminated with gas should immediately be removed.
- Burns and other serious skin conditions may result from contact with gas.

Failure to follow the advice above could result in serious injury or death.

# SAFETY FIRST

## Helmet and Clothing



### **⚠ DANGER**

A helmet is one of the most important pieces of riding gear as it offers protection against head injuries. You and your passenger's helmet should be carefully chosen and should fit you or your passenger's head comfortably and securely. A brightly colored helmet will increase a rider's (or passenger's) visibility to other operators of road vehicles.

An open face helmet offers some protection in an accident though a full face helmet will offer more.

Always wear a visor or approved goggles to help vision and to protect your eyes.

Failure to follow the advice above will result in serious injury or death.

### **⚠ WARNING**

When riding the motorcycle, both rider and passenger (on models where carrying a passenger is permitted) must always wear appropriate clothing including a motorcycle helmet, eye protection, gloves, boots, trousers (close fitting around the knee and ankle) and a brightly colored jacket.

During off-road use (on models suitable for off-road use), the rider must always wear appropriate clothing including trousers and boots.

Brightly colored clothing will considerably increase a rider's (or passenger's) visibility to other operators of road vehicles.

Although full protection is not possible, wearing correct protective clothing can reduce the risk of serious injury or death.

When choosing a helmet, always look for a DOT (Department of Transport) sticker indicating that the helmet has DOT approval. Do not buy a helmet without DOT approval.

## Parking

### WARNING

Always switch off the engine and remove the ignition key before leaving the motorcycle unattended. By removing the key, the risk of use of the motorcycle by unauthorized or untrained persons is reduced.

When parking the motorcycle, always remember the following:

- Engage first gear to help prevent the motorcycle from rolling off the stand.
- The engine, radiator, exhaust system, rear suspension unit and brakes will be hot after riding. DO NOT park where pedestrians, animals and/or children are likely to touch the motorcycle.
- Do not park on soft ground or on a steeply inclined surface. Parking under these conditions may cause the motorcycle to fall over.

For further details, refer to the How to Ride the Motorcycle section of this Owner's Handbook.

Failure to follow the advice above could result in damage to property, serious injury or death.

## Parts and Accessories

### WARNING

Owners should be aware that the only approved parts, accessories and conversions for any Triumph motorcycle are those which carry official Triumph approval.

We recommend accessories and conversions be completed by a competent person with the specialist knowledge and technical understanding of motorcycles, such as an authorized Triumph dealer.

In particular, it is extremely hazardous to install or replace parts or accessories whose installation requires the dismantling of, or addition to, either the electrical or fuel systems and any such modification could cause a safety hazard.

The installation of any non-approved parts, accessories or conversions may affect the handling, stability or other aspect of the motorcycle operation leading to loss of motorcycle control which could result in serious injury or death.

Triumph does not accept any liability whatsoever for defects caused by the installation of non-approved parts, accessories or conversions.

Triumph does not accept any liability whatsoever for defects caused by the incorrect installation of approved parts, accessories or conversions.

# SAFETY FIRST

## Maintenance and Equipment

### WARNING

Whenever there is doubt as to the correct or safe operation of this Triumph motorcycle, contact a competent person with the specialist knowledge and technical understanding of motorcycles, such as an authorized Triumph dealer.

Operation of an incorrectly performing motorcycle may aggravate a fault and may also compromise safety.

Continued operation of an incorrectly performing motorcycle may affect the handling, stability or other aspect of the motorcycle operation leading to loss of motorcycle control which could result in serious injury or death.

### WARNING

Make sure all equipment that is required by law is installed and functioning correctly.

The removal or alteration of the motorcycle's lights, mufflers, emission or noise control systems can violate the law.

Incorrect or improper modification may affect the handling, stability or other aspect of the motorcycle operation leading to loss of motorcycle control which could result in serious injury or death.

### WARNING

If the motorcycle is involved in an accident, collision or fall, it must be taken for inspection and repair.

Inspections and repairs must be completed by a competent person with the specialist knowledge and technical understanding of motorcycles, such as an authorized Triumph dealer.

Any accident can cause damage to the motorcycle that, if not correctly repaired, may cause a second accident which could result in serious injury or death.

## Riding

### DANGER

Never ride the motorcycle when fatigued or under the influence of alcohol or other drugs.

Riding when under the influence of alcohol or other drugs is illegal.

Riding when fatigued or under the influence of alcohol or other drugs reduces the rider's ability to maintain control leading to loss of motorcycle control which will result in serious injury or death.

### WARNING

All riders must be licensed to operate the motorcycle.

Operation of the motorcycle without a license is illegal and could lead to prosecution.

Operation of the motorcycle without formal training in the correct riding techniques that are necessary to become licensed is dangerous.

Failure to follow the advice above may lead to loss of motorcycle control which could result in serious injury or death.

### WARNING

Always ride defensively and wear the protective equipment mentioned elsewhere in this Safety First section.

Remember, in an accident, a motorcycle does not give the same impact protection as a car.

Failure to follow the advice above could result in serious injury or death.

### WARNING

This motorcycle should be operated within the legal speed limits for the particular road traveled.

Riding a motorcycle at high speeds can be dangerous since the time available to react to a hazard is greatly reduced at high speeds.

Always reduce speed in potentially hazardous driving conditions such as bad weather or heavy traffic.

Failure to follow the advice above may lead to loss of motorcycle control which could result in serious injury or death.

**⚠ WARNING**

Continually observe and react to changes in road surface, traffic and wind conditions. All two-wheeled vehicles are subject to external forces which may affect the handling, stability or other aspect of the motorcycle operation.

These forces include but are not limited to:

- Wind draft from passing vehicles
- Potholes, uneven or damaged road surfaces
- Bad weather
- Rider error.

Always operate the motorcycle at moderate speed and away from heavy traffic until you have become thoroughly familiar with its handling and operating characteristics. Never exceed the legal speed limit.

Failure to follow the advice above may lead to loss of motorcycle control which could result in serious injury or death.

**Wobble/Weave**

A weave is a relatively slow oscillation of the rear of the motorcycle, while a wobble is a rapid, possibly strong shaking of the handlebar. These are related but distinct stability problems usually caused by excessive weight in the wrong place, or by a mechanical problem such as worn or loose bearings or under-inflated or unevenly worn tires.

Your solution to both situations is the same. Keep a firm hold on the handlebars without locking arms or fighting the steering. Smoothly ease off the throttle to slow gradually. Do not apply the brakes, and do not accelerate to try to stop the wobble or weave. In some cases, it helps to shift your body weight forward by leaning over the tank.

Copyright © 2005 Motorcycle Safety Foundation. All rights reserved. Used with permission.

## Handlebars and Footrests

### WARNING

The rider must maintain control of the motorcycle by keeping hands on the handlebars at all times.

The handling and stability of a motorcycle will be affected if the rider removes their hands from the handlebars.

Failure to follow the advice above may lead to loss of motorcycle control which could result in serious injury or death.

### WARNING

The rider and passenger (if applicable) must always use the footrests provided, during operation of the motorcycle.

By using the footrests, both rider and passenger will reduce the risk of inadvertent contact with any motorcycle components and will also reduce the risk of injury from entrapment of clothing.

Failure to follow the advice above may lead to loss of motorcycle control which could result in serious injury or death.

### WARNING

Always replace the bank angle indicators before they are worn to their maximum limit.

Use of a motorcycle with bank angle indicators worn beyond the maximum limit will allow the motorcycle to be banked to an unsafe angle.

Banking to an unsafe angle may lead to loss of motorcycle control which could result in serious injury or death.

### WARNING

The bank angle indicators must not be used as a guide to how far the motorcycle may be safely banked.

This depends on many various conditions including, but not limited to:

- Road surface
- Tire condition
- Weather.

Banking to an unsafe angle may lead to loss of motorcycle control which could result in serious injury or death.

### WARNING

When banking and the bank angle indicator, attached to the rider's footrest, makes contact with the ground, the motorcycle is nearing its bank angle limit.

A further increase of the banking angle is unsafe.

Banking to an unsafe angle may lead to loss of motorcycle control which could result in serious injury or death.

# WARNING LABELS

## Left Hand Side

The labels detailed on this and the following pages draw your attention to important safety information in this handbook. Before riding, make sure that all riders have understood and complied with all the information to which these labels relate.

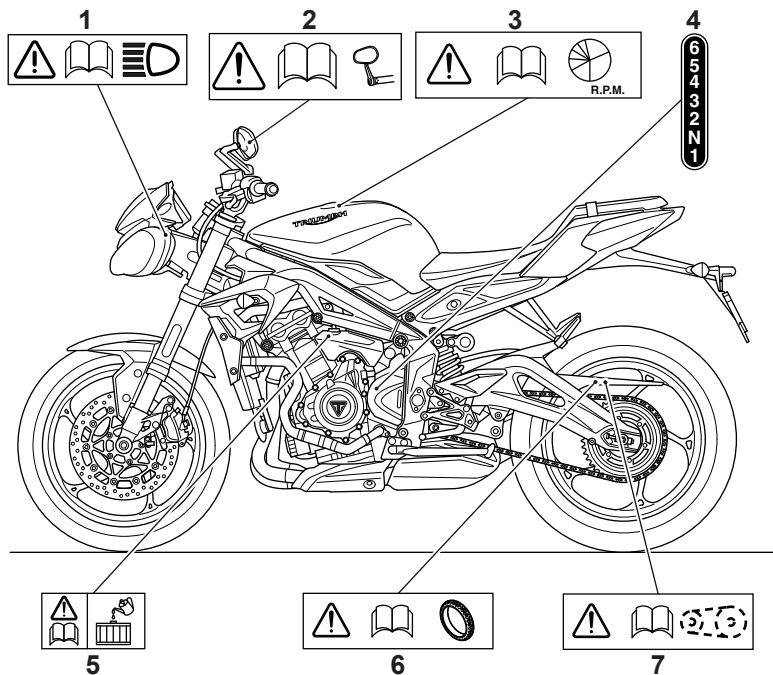

1. Headlights (page 193)
2. Mirrors (page 167)
3. Breaking-In (page 118)
4. Gears (page 124)

5. Coolant (page 150)
6. Tires (page 182)
7. Drive Chain (page 156)



## Right Hand Side

### NOTICE

All warning labels and decals, with the exception of the Breaking-in label, are mounted on the motorcycle using a strong adhesive. In some cases, labels are installed prior to an application of paint lacquer. Therefore, any attempt to remove the warning labels will cause damage to the paintwork or bodywork.

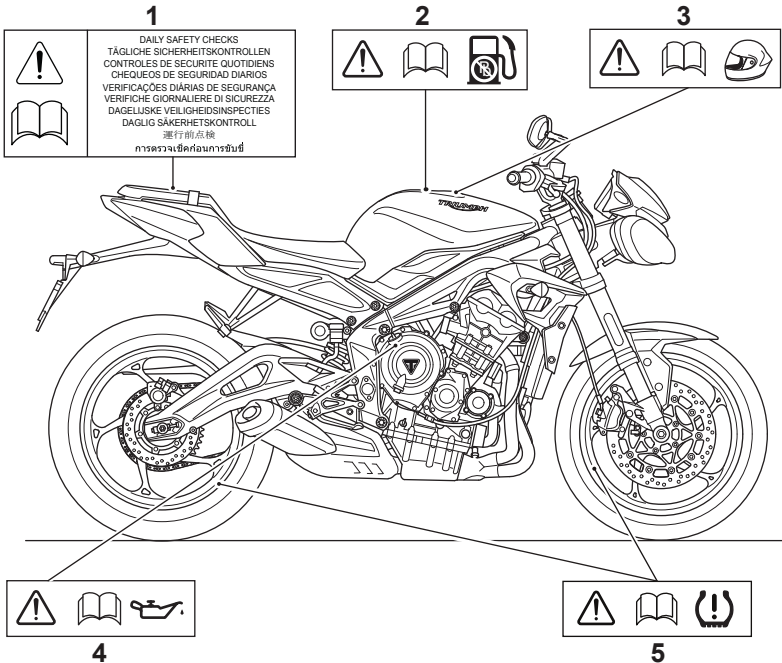

1. Daily Safety Checks (page 119)
2. Unleaded Fuel (page 105)
3. Helmet (page 10)

4. Engine Oil (page 147)
5. Tire Pressure Monitoring System (TPMS) (if equipped) (page 184)

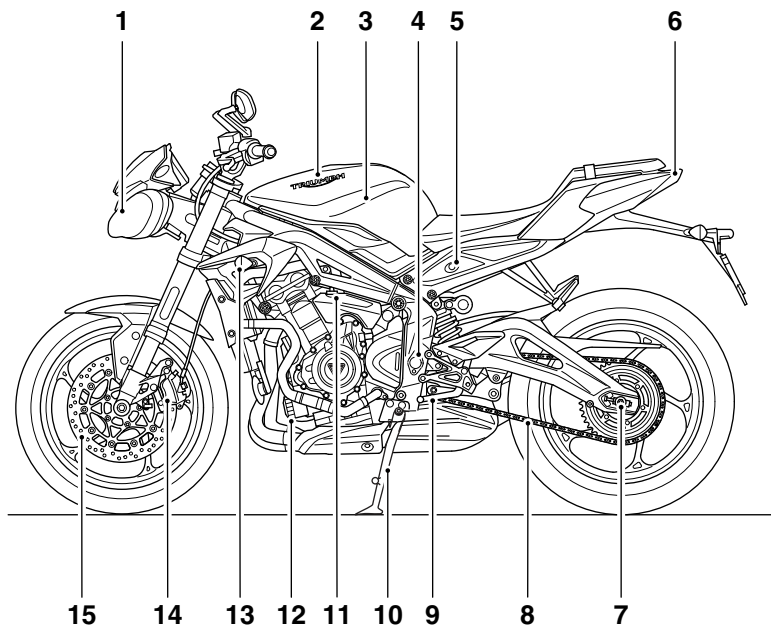

- |                         |                            |
|-------------------------|----------------------------|
| 1. Headlight            | 9. Gear shift pedal        |
| 2. Fuel filler cap      | 10. Side stand             |
| 3. Fuel tank            | 11. Coolant expansion tank |
| 4. Rear suspension unit | 12. Oil filter             |
| 5. Seat lock            | 13. Front turn signal      |
| 6. Tail light           | 14. Front brake caliper    |
| 7. Drive chain adjuster | 15. Front brake disc       |
| 8. Drive chain          |                            |

## Parts Identification - Continued

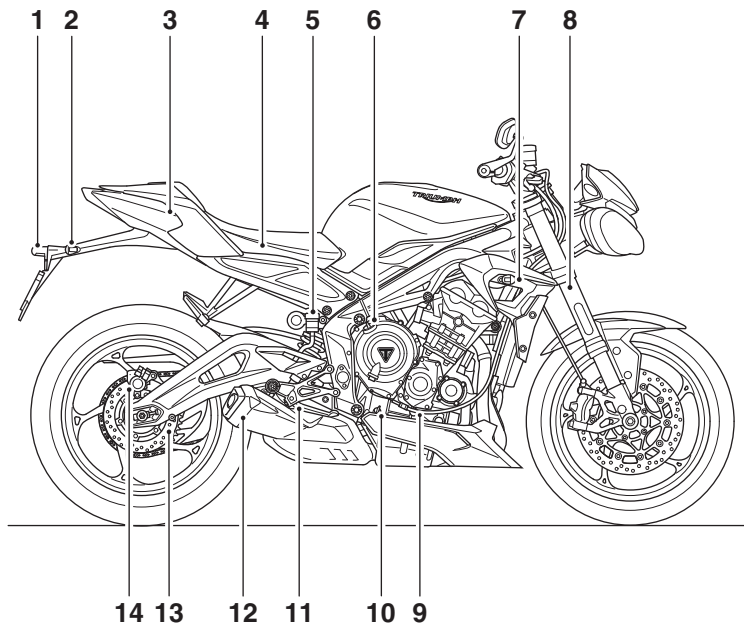

- |                                  |                               |
|----------------------------------|-------------------------------|
| 1. License plate light           | 8. Front fork                 |
| 2. Rear turn signal              | 9. Clutch cable               |
| 3. Tool kit (under seat)         | 10. Engine oil level dipstick |
| 4. Battery (under seat)          | 11. Rear brake pedal          |
| 5. Rear brake fluid reservoir    | 12. Muffler                   |
| 6. Oil filler cap                | 13. Rear brake disc           |
| 7. Radiator/Coolant pressure cap | 14. Rear brake caliper        |

## Rider View

Street Triple R, Street Triple R - LRH and Street Triple S (40.2 cu in (660 cc))

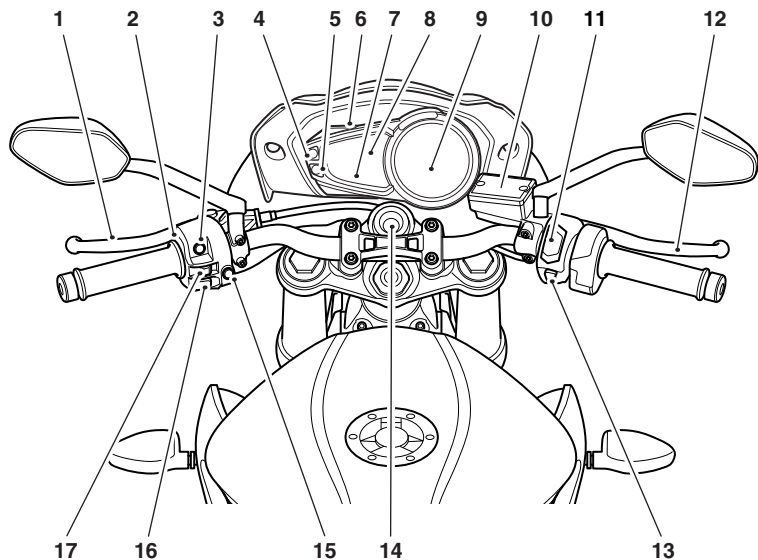

- |                              |                                 |
|------------------------------|---------------------------------|
| 1. Clutch lever              | 10. Front brake fluid reservoir |
| 2. High beam button          | 11. Engine stop/start switch    |
| 3. Instrument TRIP button    | 12. Front brake lever           |
| 4. SCROLL button             | 13. Hazard warning light switch |
| 5. SET button                | 14. Ignition switch             |
| 6. Instrument assembly (LCD) | 15. Mode button                 |
| 7. Trip computer display     | 16. Horn button                 |
| 8. Speedometer               | 17. Turn signal switch          |
| 9. Tachometer                |                                 |

## Street Triple RS

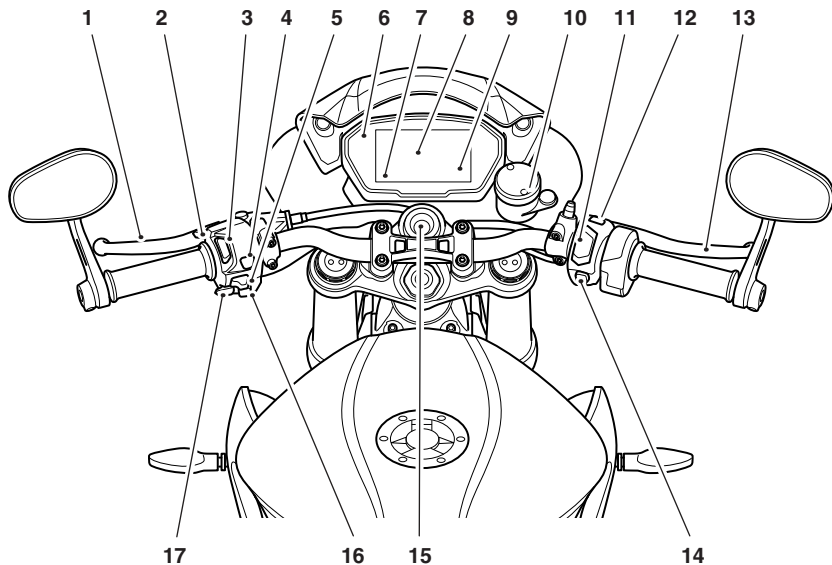

- |  |                                 |
|--|---------------------------------|
| 1. Clutch lever                                    | 9. Tachometer                   |
| 2. High beam/pass button                           | 10. Front brake fluid reservoir |
| 3. Daytime Running lights (DRL) switch if equipped | 11. Engine start/stop switch    |
| 4. MODE button                                     | 12. Hazard warning light switch |
| 5. Turn signal switch                              | 13. Front brake lever           |
| 6. Instrument assembly (TFT)                       | 14. HOME button                 |
| 7. Information tray/Mode display                   | 15. Ignition switch             |
| 8. Speedometer                                     | 16. Joystick selection button   |
|  | 17. Horn button                 |

This page intentionally left blank

### Vehicle Identification Number (VIN)

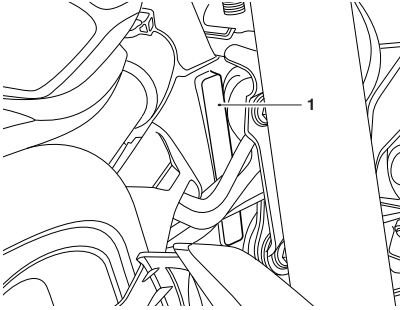

#### 1. Vehicle identification number

The Vehicle Identification Number (VIN) is stamped into the steering head area of the frame. It is also displayed on a label attached to the left hand side of the frame, adjacent to the radiator cowl.

Record the vehicle identification number in the space provided below.

### Engine Serial Number

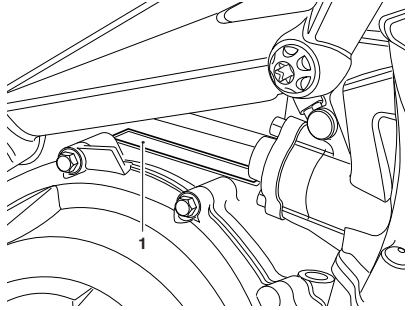

#### 1. Engine serial number

The engine serial number is stamped on the engine crankcase, directly above the clutch cover.

Record the engine serial number in the space provided below.

This page intentionally left blank



## Table of Contents

Controls.....	28
Throttle Control.....	28
Ignition Switch/Steering Lock.....	29
Ignition Key.....	30
Engine Immobilizer.....	31
Brake Lever Adjusters.....	31
Clutch Lever Adjusters.....	33
Right Handlebar Switches.....	34
Left Handlebar Switches.....	36
Instruments.....	39
TFT Instrument Display.....	40
Instrument Display Layout.....	41
Warning Lights.....	42
Warning and Information Messages.....	47
Odometer and Speedometer.....	48
Tachometer.....	49
Fuel Gage.....	49
Coolant Temperature Gage.....	50
Ambient Air Temperature.....	50
Gear Position Display.....	51
Display Styles.....	52
Display Navigation.....	52
Riding Modes.....	53
Riding Mode Selection.....	53
Main Menu.....	55
Information Tray.....	69
Instrument Panel Position Adjustment.....	75

# GENERAL INFORMATION

Liquid Crystal Display (LCD) Instruments .....	77
Instrument Panel Layout .....	78
Warning Lights .....	79
Speedometer and Odometer .....	84
Tachometer .....	84
Gear Position Display .....	84
Coolant Temperature Gage .....	85
Fuel Gage .....	85
Instrument SCROLL/SET Buttons .....	86
Traction Control (TC) Disable .....	86
Clock .....	87
Service Interval Announcement (SIA) .....	88
Gear Shift Lights .....	89
UnitS (Imperial, US or Metric) .....	90
Trip Meter .....	92
Lap Timer (if equipped) .....	94
Riding Mode Selection .....	97
RAIN Mode .....	98
ROAD Mode .....	98
SPORT Mode (Street Triple R only) .....	98
RIDER Mode (Street Triple R only) .....	99
Setting the RIDER Mode Options .....	100
Selecting a Riding Mode – Motorcycle Stationary .....	102
Selecting a Riding Mode – Motorcycle Moving .....	103
Fuel .....	105
Refueling .....	107
Traction Control (TC) .....	109
Traction Control Settings .....	109
Tire Pressure Monitoring System (TPMS) (if equipped) .....	110
Tire Pressure Warning Light (if equipped with TPMS) .....	110
Tire Pressure Sensor Serial Number .....	111
Tire Pressures .....	112
Replacement Tires .....	113
Sensor Batteries .....	113
Side Stand .....	113

Seats.....	114
Seat Care.....	114
Rider's Seat.....	114
Passenger Seat and Seat Cowl.....	115
Owner's Handbook and Tool Kit.....	116
Universal Serial Bus (USB) Socket.....	116
Breaking-In.....	118
Daily Safety Checks.....	119

## Controls

### Throttle Control

An electronic throttle twist grip controls the opening and closing of the throttles via the engine's electronic control module. There are no direct-acting cables in the system.

The throttle grip has a resistive feel to it as it is rolled rearwards to open the throttles. When the grip is released it will return to the throttle closed position by its internal return spring and the throttles will close.

There are no user adjustments for the throttle control.

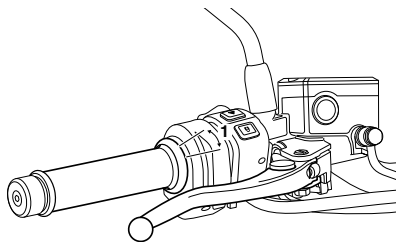

#### 1. Throttle closed position

### **!** WARNING

Reduce speed and do not continue to ride for longer than is necessary with the Malfunction Indicator Light (MIL) illuminated. The fault may affect engine performance, exhaust emissions and fuel consumption.

The fault must be checked and rectified by a competent person with the specialist knowledge and technical understanding of motorcycles, such as an authorized Triumph dealer.

Reduced engine performance could cause a dangerous riding condition, leading to loss of motorcycle control which could result in serious injury or death.

If there is a malfunction with the throttle control the Malfunction Indicator Light (MIL) becomes illuminated and one of the following engine conditions may occur:

- ▼ MIL illuminated, restricted engine RPM and throttle movement
- ▼ MIL illuminated, limp-home mode with the engine at a fast idle condition only
- ▼ MIL illuminated, engine will not start.

For all of the above conditions contact an authorized Triumph dealer as soon as possible to have the fault checked and rectified.

### Brake Use

At low throttle opening (approximately 20°), the brakes and throttle can be used together.

At high throttle opening (greater than 20°), if the brakes are applied for longer than two seconds the throttles will close and the engine speed will reduce. To return to normal throttle operation, release the throttle control, release the brakes and then reopen the throttle.

### Ignition Switch/Steering Lock

#### ⚠ WARNING

For reasons of security and safety, always turn the ignition to the OFF or PARK (if equipped) position and remove the key when leaving the motorcycle unattended.

Any unauthorized use of the motorcycle may lead to loss of motorcycle control which could result in serious injury or death.

#### ⚠ WARNING

With the key in the LOCK or PARK (if equipped) position, the steering will become locked.

Never turn the key to the LOCK or PARK (if equipped) positions while the motorcycle is moving as this will cause the steering to lock.

Locked steering will lead to loss of motorcycle control which could result in serious injury or death.

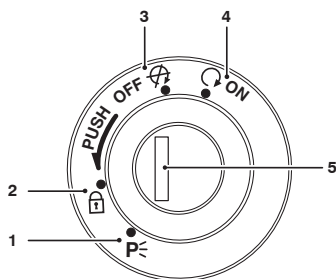

1. PARK position
2. LOCK position
3. OFF position
4. ON position
5. Ignition switch/Steering lock

#### Switch Operation

This is a four position, key operated switch. The key can be removed from the switch only when it is in the OFF, LOCK or P (PARK) position.

**TO LOCK:** Turn the steering fully to the left, turn the key to the OFF position, push and fully release the key, then rotate it to the LOCK position.

**PARKING:** Turn the key from the LOCK position to the P position. The steering will remain locked.

## GENERAL INFORMATION

### NOTICE

Do not leave the steering lock in the P position for long periods of time as this will cause the battery to discharge.

### Ignition Key

#### ⚠ WARNING

Additional keys, key rings/chains or items attached to the ignition key may interfere with the steering.

Remove all additional keys, key rings/chains and items from the ignition key before riding the motorcycle.

Failure to follow the advice above may lead to loss of motorcycle control which could result in serious injury or death.

### NOTICE

Additional keys, key rings/chains or items attached to the ignition key may cause damage to the motorcycle's painted or polished components.

Remove all additional keys, key rings/chains and items from the ignition key before riding the motorcycle.

### NOTICE

Do not store the spare key with the motorcycle as this will reduce all aspects of security.

### NOTICE

Key functions may be disrupted by electronic devices, environmental electrical noise sources and metal objects.

Avoid storing and using the key near the following:

- Electrical service masts, radio masts and power distribution infrastructure
- Garage door opener devices
- Radio-Frequency Identification (RFID) access cards or fobs
- Metal, metallic card holders and aluminum items
- Other vehicle electronic keys
- In panniers or top boxes
- Wireless communication devices such as mobile phones, tablets, laptops, portable game systems, audio players, radios and chargers.

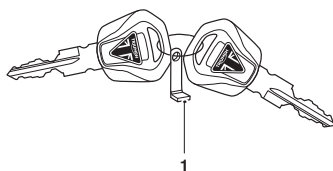

#### 1. Key number tag

In addition to operating the ignition switch/steering lock, the ignition key is required to operate the seat lock and fuel tank cap.

When the motorcycle is delivered from the factory, two ignition keys are supplied together with a small tag bearing the key number. Make a note of the key number and store the spare key and key number tag in a safe place away from the motorcycle.

There is a transponder within the ignition keys to turn off the engine immobilizer. To make sure the immobilizer functions correctly, always have only one of the ignition keys near the ignition switch. Having two ignition keys near the switch may interrupt the signal between the transponder and the engine immobilizer. In this situation the engine immobilizer will remain active until one of the ignition keys is removed.

Always get replacement keys from your authorized Triumph dealer. Replacement keys must be 'paired' with the motorcycle's immobilizer by your authorized Triumph dealer.

### Engine Immobilizer

The ignition barrel housing acts as the antenna for the engine immobilizer. When the ignition switch is turned to the OFF position and the ignition key is removed, the engine immobilizer is active (see page 80). The engine immobilizer is deactivated when the ignition key is in the ignition switch and it is turned to the ON position.

### Brake Lever Adjusters

#### **⚠ WARNING**

Do not attempt to adjust the levers with the motorcycle in motion as this could lead to loss of motorcycle control.

After adjusting the levers, operate the motorcycle in an area free from traffic to gain familiarity with the new lever setting.

Do not loan your motorcycle to anyone as they may change the lever setting from the one you are familiar leading to loss of motorcycle control which could result in serious injury or death.

### Brake Lever - Street Triple RS

There are two adjusters installed to the brake lever; a span adjuster and a ratio adjuster.

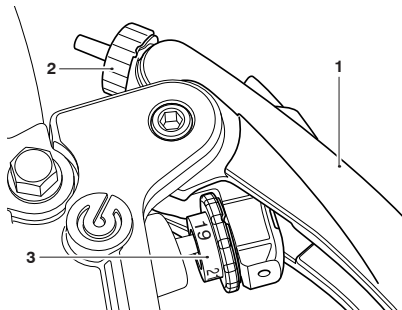

1. Brake lever
2. Span adjuster
3. Ratio adjuster

## GENERAL INFORMATION

### Span Adjuster

The span adjuster allows the distance from the handlebar to the brake lever to be changed to suit the span of the rider's hands.

To adjust the brake lever span:

- ▼ Rotate the span adjuster counter-clockwise to decrease the distance to the handlebar or clockwise to increase the distance from the handlebar.
- ▼ The distance from the handlebar grip to the released brake lever is shortest when the span adjuster is rotated fully counter-clockwise.

### Ratio Adjuster

The ratio adjuster moves the brake master cylinder push rod to the left or right in 0.04 in (1 mm) increments from 0.75 in (19 mm) to 0.83 in (21 mm).

To adjust the brake lever ratio:

- ▼ Rotate the ratio adjuster to the rider's preferred position. The ratio adjuster can be rotated both clockwise and counter-clockwise to set the required preference.
- ▼ An audible click can be heard when the ratio adjuster is locked into position.
- ▼ The ratio adjuster has three lever positions:
  - ▼ 19 (0.75 in (19 mm)) for a softer brake feel with a longer lever travel
  - ▼ 20 (0.78 in (20 mm)) for a firmer brake feel and a medium lever travel
  - ▼ 21 (0.8 in (21 mm)) for a firm brake feel and a shorter lever travel.

### Brake Lever - Street Triple S (40.2 cu in (660 cc))

A span adjuster is installed to the brake lever. The adjuster allows the distance from the handlebar to the brake lever to be changed to suit the span of the rider's hand.

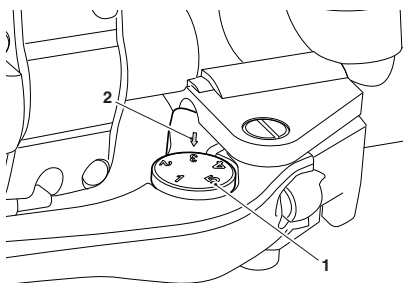

1. Adjuster wheel
2. Arrow mark

To adjust the brake lever:

- ▼ Push the brake lever forward and turn the adjuster wheel to align one of the numbered positions with the arrow mark on the lever holder.
- ▼ The distance from the handlebar grip to the released brake lever is shortest when set to number five and longest when set to number one.



## Clutch Lever Adjusters

### **⚠ WARNING**

Do not attempt to adjust the levers with the motorcycle in motion as this could lead to loss of motorcycle control.

After adjusting the levers, operate the motorcycle in an area free from traffic to gain familiarity with the new lever setting.

Do not loan your motorcycle to anyone as they may change the lever setting from the one you are familiar leading to loss of motorcycle control which could result in serious injury or death.

## Clutch Lever - Street Triple S (40.3 cu in (660 cc))

A span adjuster is installed to the clutch lever. The adjuster allows the distance from the handlebar to the clutch lever to be changed to suit the span of the rider's hand.

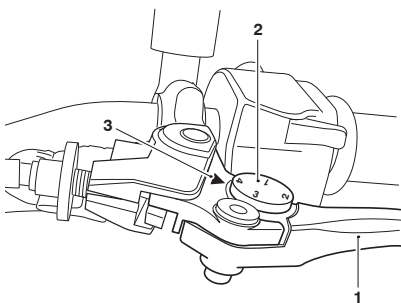

1. Clutch lever
2. Adjuster wheel
3. Triangular mark

To adjust the clutch lever:

- ▼ Push the clutch lever forward and turn the adjuster wheel to align one of the numbered positions with the triangular mark on the lever holder.
- ▼ The distance from the handlebar grip to the released clutch lever is shortest when set to number four and longest when set to number one.

## Clutch Lever - Street Triple RS

A span adjuster is installed to the clutch lever. The adjuster allows the distance from the handlebar to the clutch lever to be changed to suit the span of the rider's hand.

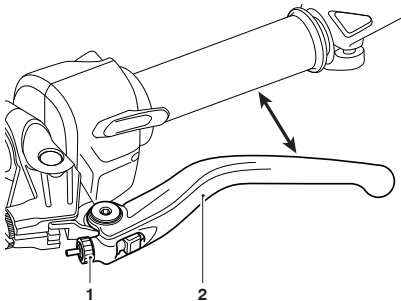

1. Span adjuster
2. Clutch lever

To adjust the clutch lever span:

- ▼ Rotate the span adjuster counter-clockwise to decrease the distance to the handlebar or clockwise to increase the distance from the handlebar.
- ▼ The distance from the handlebar grip to the released clutch lever is shortest when the adjuster wheel is adjusted fully counter-clockwise.

# GENERAL INFORMATION

## Right Handlebar Switches

### Street Triple RS Only

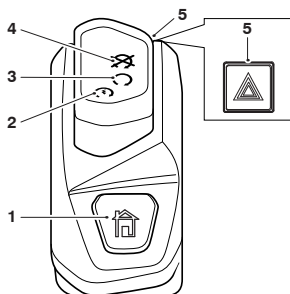

1. Home button
2. START position
3. RUN position
4. STOP position
5. Hazard warning light switch

### STOP Position

The STOP position is for emergency use. If an emergency arises which requires the engine to be stopped, move the engine start/stop switch to the STOP position.

#### NOTICE

Although the engine stop switch stops the engine, it does not turn off all the electrical circuits and may cause difficulty in restarting the engine due to a discharged battery. Ordinarily, only the ignition switch should be used to stop the engine.

Do not leave the ignition switch in the ON position unless the engine is running as this may cause damage to electrical components and will discharge the battery.

### RUN Position

In addition to the ignition switch being turned to the ON position, the engine start/stop switch must be in the RUN position for the motorcycle to operate.

### START Position

The START position operates the electric starter. For the starter to operate, the clutch lever must be pulled to the handlebar.

#### NOTICE

Even if the clutch lever is pulled to the handlebar, the starter will not operate if the side stand is down and a gear is engaged.

### Hazard Warning Lights

To turn the hazard warning lights on or off, press and release the hazard warning light switch.

The ignition must be switched ON for the hazard warning lights to function.

The hazard warning lights will remain on if the ignition is switched OFF, until the hazard warning light switch is pressed again.

### HOME Button

The HOME button is used to access the main menu on the instrument display.

Press and release the HOME button to select between the main menu and instrument display.

All messages that appear in the instrument display must be acknowledged by pressing the Joystick center before the HOME button can be operated.

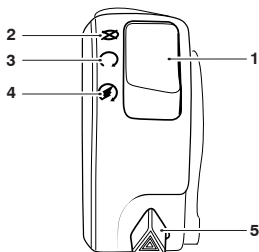
**All Models except Street Triple RS**

1. Engine start/stop switch
2. STOP position
3. RUN position
4. START position
5. Hazard warning light switch

**STOP Position**

The STOP position is for emergency use. If an emergency arises which requires the engine to be stopped, move the engine start/stop switch to the STOP position.

**NOTICE**

Although the engine stop switch stops the engine, it does not turn off all the electrical circuits and may cause difficulty in restarting the engine due to a discharged battery. Ordinarily, only the ignition switch should be used to stop the engine.

Do not leave the ignition switch in the ON position unless the engine is running as this may cause damage to electrical components and will discharge the battery.

**RUN Position**

In addition to the ignition switch being turned to the ON position, the engine start/stop switch must be in the RUN position for the motorcycle to operate.

**START Position**

The START position operates the electric starter. For the starter to operate, the clutch lever must be pulled to the handlebar.

**NOTICE**

Even if the clutch lever is pulled to the handlebar, the starter will not operate if the side stand is down and a gear is engaged.

**Hazard Warning Lights**

To turn the hazard warning lights on or off, press and release the hazard warning light switch.

The ignition must be switched ON for the hazard warning lights to function.

The hazard warning lights will remain on if the ignition is switched to the PARK position, until the hazard warning light switch is pressed again.

# GENERAL INFORMATION

## Left Handlebar Switches

### Street Triple RS Only

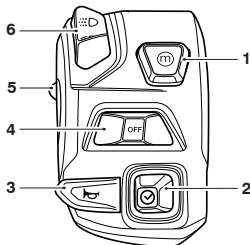

1. Mode button
2. Joystick
3. Horn button
4. Turn signal switch
5. High beam button
6. Dipped beam/Daytime Running Lights (DRL) switch (if equipped)

### Mode Button

When the MODE button is pressed and released it will activate the Riding Mode Selection Menu in the multifunction display screen. Further presses of the mode button will scroll through the available riding modes (see page 53).

### Joystick Button

The JOYSTICK is used to operate the following functions of the instruments:

- ▼ Up - scroll the menu bottom to top
- ▼ Down - scroll the menu top to bottom
- ▼ Left - scroll the menu to the left
- ▼ Right - scroll the menu to the right
- ▼ Center - press to confirm selection

### Horn Button

When the horn button is pushed, with the ignition switch turned on, the horn will sound.

### Turn Signal Switch

When the turn signal switch is pushed to the left or right, the corresponding turn signals will flash on and off.

The turn signals can be canceled manually. To manually turn off the turn signal, press and release the turn signal switch in the central position.

Automatic self-canceling turn signals can be activated in the Bike Set Up function on the display, refer to page 58.

There are two options available:

- ▼ Manual - The self-canceling function is off. The turn signals must be manually canceled.
- ▼ Auto - The self-canceling function is on. The turn signals will activate for eight seconds plus an additional 65 meters.

## NOTICE

If the motorcycle stops for any reason, the signals will flash for the remainder of the time and distance unless manually canceled by the rider.

### Daytime Running Lights (DRL) (if equipped)



When the ignition is switched ON and the daytime running lights switch is set to Daytime Running Lights, the daytime running lights warning light will illuminate. During daylight hours, the Daytime Running Lights (DRL) improve the visibility of the motorcycle to other road users. Low beam headlights must be used in any other conditions unless the road conditions allow for high beam headlights to be used.

The daytime running lights and low beam headlights are operated manually using a switch on the left hand switch housing, see page 45.

#### **WARNING**

Do not ride for longer than necessary in poor ambient light conditions with the Daytime Running Lights (DRL) in use.

Riding with the Daytime Running Lights when dark, in tunnels or where poor ambient light is apparent may reduce the riders vision or blind other road users.

Blinding other road users or reduced vision in low ambient light levels may lead to loss of motorcycle control which could result in serious injury or death.

### High Beam Button

If the Daytime Running Light (DRL) switch is in the dip beam position, when the High Beam button is operated then the high beam will be switched on. Each press of the button will swap between dip and high beam.

If the DRL switch is in the daytime running lights position, then press and hold the High Beam button to turn the high beam on. It will remain on as long as the button is held in and will turn off as soon as the button is released.

#### **NOTICE**

A lighting on/off switch is not fitted to this model. The position light, dipped headlight, rear light and licence plate light all function automatically when the ignition is turned to the ON position.

The headlight will function when the ignition switch is turned to the ON position.

# GENERAL INFORMATION

## All Models except Street Triple RS

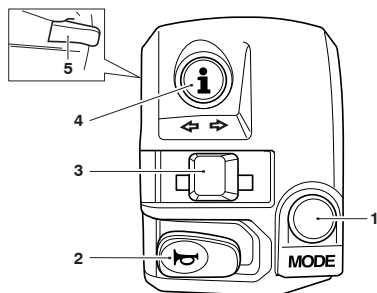

1. **MODE button**
2. **Horn button**
3. **Turn signal switch**
4. **TRIP button**
5. **High beam button**

### Mode Button

When the MODE button is pressed and released it will activate the Riding Mode Selection Menu in the multifunction display screen. Further presses of the mode button will scroll through the available riding modes, see page 97.

### Trip Button

The SCROLL button is used to operate the following functions of the instruments:

- ▼ Trip meter
- ▼ Odometer
- ▼ Tire Pressure Monitoring System (if equipped).

### Turn Signal Switch

When the turn signal switch is pushed to the left or right and released, the corresponding turn signals will flash on and off. To turn off the turn signals, push and release the switch in the central position.

### Horn Button

When the horn button is pushed, with the ignition switch turned on, the horn will sound.

### High Beam Button

When the high beam button is pressed the high beam will be switched on. Each press of the button will swap between dip and high beam.

The headlight will function when the ignition switch is turned to the ON position. The headlight will go off while pressing the starter button until the engine starts.

A lighting on/off switch is not installed on this model. The position light, brake/tail light and license plate light all function automatically when the ignition is turned to the ON position.

A Pass feature is not available on this model.

## Instruments

There are two different types of instrument display depending on the motorcycle model.

### TFT Instrument Display

Street Triple RS models are equipped with a full color Thin Film Transistor (TFT) instrument display.

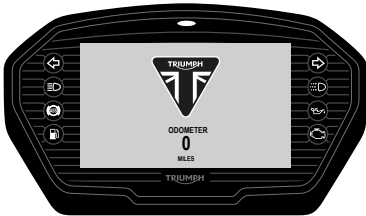

### TFT Instrument Display

For TFT instrument display operating instructions, see page 41.

### LCD Instrument Display

All models except Street Triple RS are equipped with a Liquid Crystal Display (LCD) instrument display.

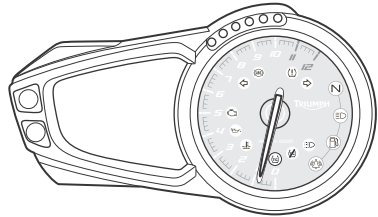

### LCD Instrument Display

For LCD instrument display operating instructions, see page 77.

# GENERAL INFORMATION

## TFT Instrument Display

### Table of Contents

Instrument Display Layout.....	41
Warning Lights.....	42
Warning and Information Messages .....	47
Odometer and Speedometer .....	48
Tachometer .....	49
Fuel Gage .....	49
Coolant Temperature Gage .....	50
Ambient Air Temperature.....	50
Gear Position Display .....	51
Display Styles.....	52
Display Navigation .....	52
Riding Modes.....	53
Riding Mode Selection.....	53
Main Menu.....	55
Information Tray .....	69
Instrument Panel Position Adjustment .....	75



## Instrument Display Layout

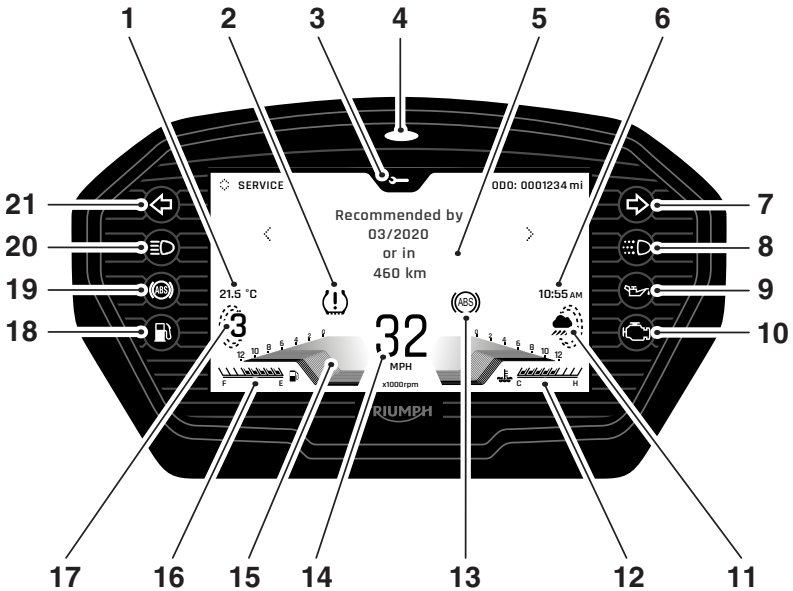

1. Air temperature
2. Tire Pressure Monitoring System (TPMS) warning light (if equipped)
3. Information tray icon
4. Alarm/immobilizer status indicator light (alarm is an accessory kit)
5. Information tray area
6. Clock
7. Right hand turn signal and hazard warning light
8. Daytime Running Light (DRL) (if equipped)
9. Oil pressure warning light
10. Engine management Malfunction Indicator Light (MIL)
11. Current riding mode
12. Coolant temperature gage
13. ABS warning light
14. Speedometer
15. Tachometer
16. Fuel gage
17. Gear position
18. Fuel level low warning light
19. ABS warning light
20. High beam warning light
21. Left hand turn signal and hazard warning light

## GENERAL INFORMATION

### Warning Lights

When the ignition is switched on, the instrument warning lights will illuminate for 1.5 seconds and will then go off (except those which remain on until the engine starts, as described in the following pages).

For additional warning and information messages, see page 47.

### Engine Management System Malfunction Indicator Light (MIL)



The Malfunction Indicator Light (MIL) for the engine management system illuminates when the ignition is switched ON (to indicate that it is working) but should not become illuminated when the engine is running.

If the engine is running and there is a fault with the engine management system the MIL will be illuminated and the general warning symbol will flash. In such circumstances, the engine management system may switch to 'limp-home' mode so that the journey may be completed, if the fault is not so severe that the engine will not run.

### WARNING

Reduce speed and do not continue to ride for longer than is necessary with the Malfunction Indicator Light (MIL) illuminated. The fault may affect engine performance, exhaust emissions and fuel consumption.

The fault must be checked and rectified by a competent person with the specialist knowledge and technical understanding of motorcycles, such as an authorized Triumph dealer.

Reduced engine performance could cause a dangerous riding condition, leading to loss of motorcycle control which could result in serious injury or death.

If the MIL flashes when the ignition is switched ON contact an authorized Triumph dealer as soon as possible to have the situation rectified. In these circumstances the engine will not start.

### Low Oil Pressure Warning Light



With the engine running, if the engine oil pressure becomes dangerously low, the low oil pressure warning light will illuminate. The low oil pressure warning light will also illuminate if the ignition is switched ON without running the engine.

**NOTICE**

If the engine oil pressure is too low, the low oil pressure warning light will illuminate.

If the low oil pressure indicator remains on, stop the engine immediately and investigate the situation.

Running the engine with low oil pressure will cause severe engine damage.

**Immobilizer/Alarm Indicator Light**

This Triumph motorcycle is equipped with an engine immobilizer which is activated when the ignition switch is turned to the OFF position.

**Without Alarm Equipped**

When the ignition switch is turned to the OFF position, the immobilizer light will flash on and off for 24 hours to show that the engine immobilizer is on. When the ignition switch is turned to the ON position the immobilizer and the indicator light will be off.

If the indicator light remains on it indicates that the immobilizer has a malfunction that requires investigation. Contact an authorized Triumph dealer as soon as possible to have the fault checked and rectified.

**With Alarm Equipped**

The immobilizer/alarm light will only illuminate when the conditions described in the genuine Triumph accessory alarm instructions are met.

**Anti-lock Braking System (ABS) Warning Light**

When the ignition switch is turned to the ON position, it is normal that the ABS warning light will flash on and off. The light will continue to flash after engine start-up until the motorcycle first reaches a speed exceeding 6 mph (10 km/h) when it will go off.

**NOTICE**

Traction control will not function if there is a malfunction with the ABS. The warning lights for the ABS, traction control and the MIL will be illuminated.

The warning light should not illuminate again until the engine is restarted unless there is a fault.

If the warning light becomes illuminated at any time while riding it indicates that the ABS has a malfunction that requires investigation.

## GENERAL INFORMATION

### WARNING

If the Anti-lock Brake System (ABS) is not functioning, the brake system will continue to function as a non-ABS equipped brake system. Do not continue to ride for longer than is necessary with the ABS warning light illuminated.

The fault must be checked and rectified by a competent person with the specialist knowledge and technical understanding of motorcycles, such as an authorized Triumph dealer.

Braking too hard will cause the wheels to lock, leading to loss of motorcycle control which could result in serious injury or death.

### WARNING

If the traction control is not functioning, care must be taken when accelerating and cornering on wet/slippery road surfaces to avoid rear wheel spin. Do not continue to ride for longer than is necessary with the engine management system Malfunction Indicator Light (MIL) and traction control warning lights illuminated.

The fault must be checked and rectified by a competent person with the specialist knowledge and technical understanding of motorcycles, such as an authorized Triumph dealer.

Hard acceleration and cornering may cause the rear wheel to spin, leading to loss of motorcycle control which could result in serious injury or death.

### Traction Control (TC) Indicator Light



The Traction Control (TC) indicator light is used to indicate that the traction control system is active and is working to limit rear wheel slip during periods of hard acceleration or under wet or slippery road conditions. Traction control will not function if there is a malfunction with the ABS. The warning lights for the ABS, traction control and the MIL will be illuminated.

If traction control is switched on:

- ▼ Under normal riding conditions the TC indicator light will remain off.
- ▼ The TC indicator light will flash rapidly when the traction control system is working to limit rear wheel slip during periods of hard acceleration or under wet or slippery road conditions.

If traction control is switched off:

- ▼ The TC indicator light will not illuminate. Instead the TC disabled warning light will be illuminated.

### Traction Control (TC) Disabled Warning Light



The TC disabled warning light should not illuminate unless traction control is switched off or there is a malfunction.

If the warning light becomes illuminated while riding, it indicates that the traction control system has a malfunction that requires investigation.

### Turn Signals



When the turn signal switch is turned to the left or right, the indicator warning light will flash on and off at the same speed as the turn signals.

### Hazard Warning Lights

To turn the hazard warning lights on or off, press and release the hazard warning light switch.

The ignition must be switched ON for the hazard warning lights to function.

The hazard warning lights will remain on if the ignition is switched OFF, until the hazard warning light switch is pressed again.

### High Beam Light



When the ignition is switched ON and the headlight dimmer switch is set to HIGH BEAM, the high beam warning light will illuminate.

### Daytime Running Lights (DRL) (if equipped)



When the ignition is switched ON and the daytime running lights switch is set to Daytime Running Lights, the daytime running lights warning light will illuminate. During daylight hours, the Daytime Running Lights (DRL) improve the visibility of the motorcycle to other road users. Dipped beam headlights must be used in any other conditions unless the road conditions allow for high beam headlights to be used.

When the dipped beam headlight is switched on, the daytime running lights warning light will be off.

The daytime running lights and dipped beam headlights are operated manually using a switch on the left hand switch housing.

## GENERAL INFORMATION

### WARNING

Do not ride for longer than necessary in poor ambient light conditions with the Daytime Running Lights (DRL) in use.

Riding with the Daytime Running Lights when dark, in tunnels or where poor ambient light is apparent may reduce the riders vision or blind other road users.

Blinding other road users or reduced vision in low ambient light levels may lead to loss of motorcycle control which could result in serious injury or death.

### Low Fuel Warning Light



The low fuel indicator will illuminate when there are approximately 3.5 litres of fuel remaining in the tank.

### Tire Pressure Warning Light (if equipped with TPMS)

### WARNING

Stop the motorcycle if the tire pressure warning light illuminates.

Do not ride the motorcycle until the tires have been checked and the tire pressures are at their recommended pressure when cold.

Failure to follow the advice above may lead to loss of motorcycle control which could result in serious injury or death.

### NOTICE

The Tire Pressure Monitoring System (TPMS) is available as an accessory option on all models.



The tire pressure warning light works with the Tire Pressure Monitoring System (TPMS) (see page 110).

The warning light will only illuminate when the front or rear tire pressure is below the recommended pressure. It will not illuminate if the tire is over inflated.

When the warning light is illuminated, the TPMS symbol indicating which is the deflated tire and its pressure will automatically be shown in the display area.

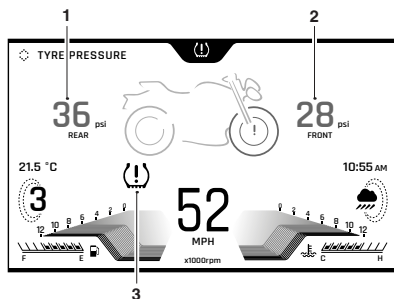

1. Rear tire indicator
2. Front tire indicator
3. Tire pressure warning light

The tire pressure at which the warning light illuminates is temperature compensated to 68°F (20°C) but the numeric pressure display associated with it is not (see page 183). Even if the numeric display seems at or close to the standard tire pressure when the warning light is on, a low tire pressure is indicated and a puncture is the most likely cause.

## Warning and Information Messages

It is possible for multiple warning and information messages to be shown when a fault occurs. Where this is the case, warning messages will take priority over information messages and the warning symbol will be shown on the display. The number of currently active warning messages is shown in the information tray.

The following Warning and Information messages may be shown if a fault is detected on the motorcycle.

	LOW OIL PRESSURE - CHECK MANUAL (red indicator)
	CHECK ENGINE (amber indicator)
	ABS SYSTEM DISABLED - CHECK MANUAL (amber indicator)
	BATTERY LOW - CHECK MANUAL (red indicator)
	SENSOR SIGNAL FRONT/REAR TIRE - CHECK MANUAL (red indicator)
	BATTERY LOW FRONT/REAR TIRE - CHECK MANUAL (amber indicator)
	TC-SYSTEM DISABLED - CHECK MANUAL (amber indicator)
	SERVICE OVERDUE - CONTACT DEALER (amber indicator)
	BULB FAULT LEFT/RIGHT FRONT/REAR TURN SIGNAL - CHECK MANUAL (amber indicator)
	CAUTION: LOW AIR TEMPERATURE - RISK OF SURFACE ICE

## GENERAL INFORMATION

If more than one message is displayed then the down arrow becomes active, push the joystick down to show other messages.

Press the joystick center to acknowledge and hide each message.

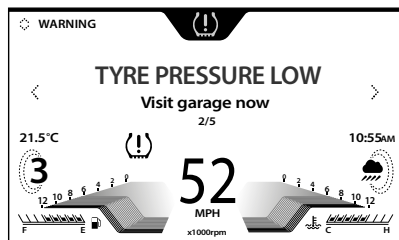

### Tire Pressure Low Warning Shown

Push the joystick left or right to review the warnings previously acknowledged.

Previously acknowledged warnings will be shown until they have been rectified.

When a warning or information message is activated, the message will be accompanied by the relevant warning or information symbol in the instrument panel.

### Odometer and Speedometer

The odometer shows the total distance that the motorcycle has traveled.

The speedometer indicates the road speed of the motorcycle.

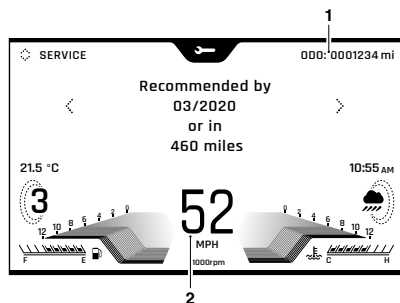

1. Odometer
2. Speedometer



## Tachometer

### NOTICE

Never allow engine speed to exceed the maximum engine speed as severe engine damage may result.

The tachometer shows the engine speed in revolutions per minute - rpm (r/min). At the end of the tachometer range there is the red zone. Engine speeds in the red zone are above maximum recommended engine speed and are also above the range for best performance.

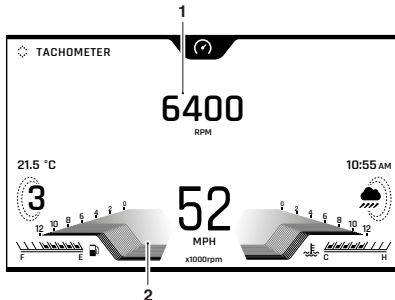

1. Engine speed (rpm) shown in a numerical format
2. Engine speed (rpm) shown in a graph format

## Fuel Gage

The fuel gage indicates the amount of fuel in the tank.

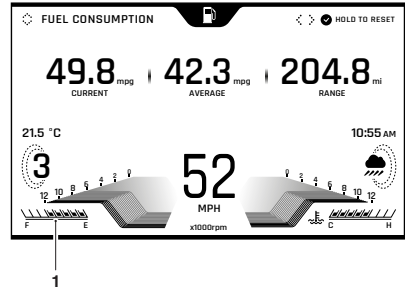

### 1. Fuel gage

The fuel gage colors described below may vary by different styles.

With the ignition switched on, a black line indicates the fuel remaining in the fuel tank.

When the fuel tank is full, a black line is shown and when empty, a gray line is shown. Other gage markings indicate intermediate fuel levels between full and empty.

The low fuel warning light will illuminate when approximately 3.5 litres of fuel is remaining in the tank and you should refuel at the earliest opportunity. The range to empty and instantaneous fuel consumption will be also shown in the Information tray. Press the joystick center to acknowledge and hide the low fuel warning.

After refueling, the fuel gage and range to empty information will be updated only while riding the motorcycle. Depending on the riding style, updating could take up to five minutes.

# GENERAL INFORMATION

## Coolant Temperature Gage

The coolant temperature gage indicates the temperature of the engine coolant.

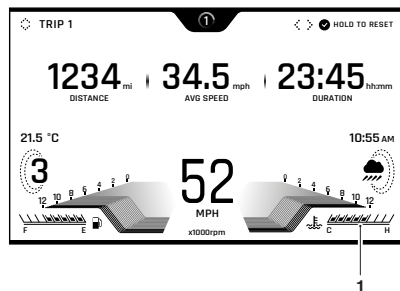

### 1. Coolant temperature gage

When the engine is started from cold the display will show gray bars. As the temperature increases more bars in the display will be shown illuminated. When the engine is started from hot the display will show the relevant number of illuminated bars, dependent on engine temperature.

The normal temperature range is between the C (Cold) and H (Hot) on the display.

With the engine running, if the engine coolant temperature becomes dangerously high, the high coolant temperature warning light on the gage will be illuminated and the gage will display in the information tray.

## NOTICE

Stop the engine immediately if the high coolant temperature warning light illuminates. Do not restart the engine until the fault has been rectified.

Severe engine damage will result from running the engine when the high coolant temperature warning light is illuminated.

## Ambient Air Temperature

The ambient air temperature is displayed as either °C or °F.

When the motorcycle is stationary the heat of the engine may affect the accuracy of the ambient temperature display.

Once the motorcycle starts moving the display will return to normal after a short time.

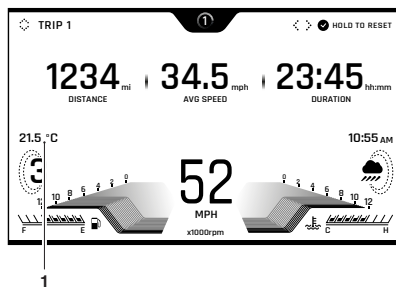

### 1. Ambient air temperature

To change the temperature from °C or °F, see page 63.

## Frost Symbol

### ⚠ WARNING

Black ice (sometimes called clear ice) can form at temperatures several degrees above freezing, 32°F (0°C), especially on bridges and in shaded areas.

Always take extra care when the temperatures are low and reduce speed in potentially hazardous driving conditions such as bad weather.

Excess speed, hard acceleration, heavy braking or hard cornering when roads are slippery may lead to loss of motorcycle control which could result in serious injury or death.



The frost symbol will illuminate if the ambient air temperature is 4°C (39°F) or lower.

The frost symbol will remain illuminated until the temperature rises to 6°C (42°F).

A message will also be shown in the information tray.

## Gear Position Display

The gear position display indicates which gear (one to six) has been engaged. When the transmission is in neutral (no gear selected), the display will show N.

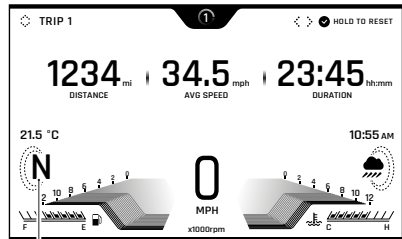

1. Gear position display (neutral position displayed)

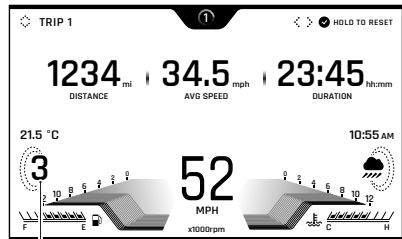

1. Gear position display (third gear displayed)

# GENERAL INFORMATION

## Display Styles

There are four different display styles to select from.



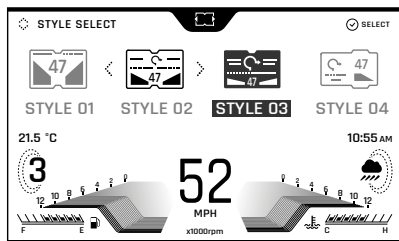







Style 03 is used for visual recognition and consistency throughout this owner's handbook.



To select a style, see page 74 for more information.

## Display Navigation

The table below describes the instrument icons and buttons used to navigate through the instrument menus described in this handbook.









	HOME button (right hand switch housing).
	MODE button (left hand switch housing).
	Joystick left/right or up/down.
	Joystick center (press).
	Selection arrow (right shown).
	Information Tray - left/right scroll using the joystick.
	Information Tray - up/down scroll using the joystick.
	Option available within the Information Tray - scroll using the joystick up/down.
	Short press (press and release) using the joystick center.
	Long press (press and hold) using the joystick center.
	Reset current feature. (only available with joystick long press).

## Riding Modes

The riding modes allow adjustment of the throttle response (MAP), Anti-lock Brake System (ABS) and Traction Control (TC) settings to suit differing road conditions and rider preferences.

Riding modes can be conveniently selected using the MODE button located on the left hand switch housing, while the motorcycle is stationary or moving (see page 53).

Five riding modes are available. If the rider edits a riding mode (other than the RIDER mode), the icon will change as shown in the table below.

Default Icon	Rider Edited Icon	Description
		RAIN
		ROAD
		SPORT
		TRACK
	-	RIDER

Each riding mode is adjustable, see page 57 for more information.

## Riding Mode Selection

### WARNING

The selection of riding modes while the motorcycle is in motion requires the rider to allow the motorcycle to coast (motorcycle moving, engine running, throttle closed, clutch lever pulled in and no brakes applied) for a brief period of time.

Riding mode selection while the motorcycle is in motion should only be attempted:

- At low speed
- In traffic free areas
- On straight and level roads or surfaces
- In good road and weather conditions
- Where it is safe to allow the motorcycle to briefly coast.

Riding mode selection while the motorcycle is in motion **MUST NOT** be attempted:

- At high speeds
- While riding in traffic
- During cornering or on winding roads or surfaces
- On steeply inclined roads or surfaces
- In poor road and weather conditions
- Where it is unsafe to allow the motorcycle to coast.

Failure to follow the advice above may lead to loss of motorcycle control which could result in serious injury or death.

## GENERAL INFORMATION

### **⚠ WARNING**

After selecting a riding mode, operate the motorcycle in an area free from traffic to gain familiarity with the new settings.

Do not loan your motorcycle to anyone as they may change the riding mode settings from the one you are familiar with.

Failure to follow the advice above may lead to loss of motorcycle control which could result in serious injury or death.

### **⚠ WARNING**

If Traction Control (TC) has been disabled in the Main Menu as described on page 59 then all TC settings that were saved for all riding modes will be overridden.

TC will remain off regardless of the riding mode selection, until it has been re-enabled or the ignition has been switched off then on again.

If the traction control is disabled, the motorcycle will handle as normal but without traction control. In this situation accelerating too hard on wet/slippery road surfaces may cause the rear wheel to slip, and may result in loss of motorcycle control which could result in serious injury or death.

The riding mode will default to ROAD when the ignition is switched ON, if the TRACK or RIDER Mode was active the last time the ignition was switched OFF with TC set to TRACK or OFF in the required mode.

Otherwise, the last selected riding mode will be remembered and activated when the ignition is switched ON.

If the mode icons are not shown when the ignition switch is in the ON position, make sure that the engine stop switch is in the RUN position.

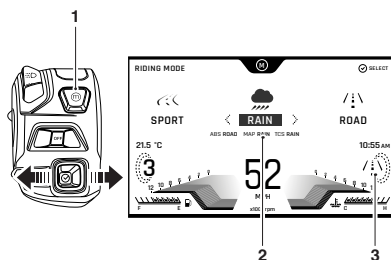

1. Mode button
2. New riding mode
3. Current riding mode

To select a riding mode:

- ▼ Press and release the MODE button on the left hand switch housing to activate the riding mode selection tray.
- ▼ The currently active riding mode icon is shown in the right hand side of the display.

To change the selected riding mode:

- ▼ Press the joystick left or right, or repeatedly press the MODE button until the required riding mode is highlighted in the center of the riding mode information tray.
- ▼ A brief press of the joystick center will select the required riding mode, and the riding mode icon in the right hand side of the display will change.
- ▼ The selected mode is activated once the following conditions for switching modes have been met:

### Motorcycle Stationary - Engine Off

- ▼ The ignition is switched ON.
- ▼ The engine stop switch is in the RUN position.

### Motorcycle Stationary - Engine Running

- ▼ Neutral gear is selected or the clutch is pulled in.

### Motorcycle in Motion

Within 30 seconds of selecting a riding mode the rider must carry out the following simultaneously:

- ▼ Close the throttle.
- ▼ Make sure that the brakes are not engaged (allow the motorcycle to coast).

If a riding mode change is not completed, the riding mode icon will alternate between the previous riding mode and the newly selected riding mode until the change is complete or it is canceled.

The riding mode selection is now complete and normal riding can be resumed.

## NOTICE

It is not possible to select TRACK or RIDER modes while the motorcycle is in motion, if the TC settings are set to TRACK or OFF in either of those modes. In this case, the motorcycle must be brought to a stop before the riding mode change can take place.

### Main Menu

To access the Main Menu:

- ▼ The motorcycle must be stationary with the ignition switched on.
- ▼ Press the HOME button on the right handlebar switch housing.
- ▼ Scroll the Main menu by pushing the joystick down/up until the required option is selected and then press the joystick center to confirm.

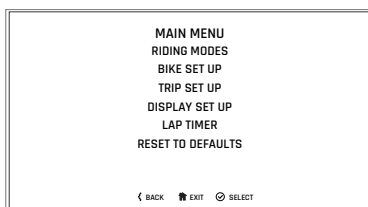

### Main Menu Screen

The MAIN MENU allows access to the following options:

### RIDING MODES

This menu allows configuration of the riding modes. For more information, see page 57.

### BIKE SETUP

This menu allows configuration of the different features of the motorcycle. For more information, see page 57.

### TRIP SETUP

This menu allows configuration of Trip 1 and Trip 2. For more information, see page 60.

# GENERAL INFORMATION

## DISPLAY SETUP

This menu allows configuration of the display options. For more information, see page 61.

## LAP TIMER

This menu allows configuration of the lap timer and the viewing of lap timer data. For more information, see page 66.

## RESET TO DEFAULTS

This menu allows all instrument settings to be returned to the default setting. For more information, see page 68.

## Riding Modes

To access the Riding Modes menu:

- ▼ From the MAIN MENU, push the joystick down and select RIDING MODES.
- ▼ Press the joystick center to confirm.

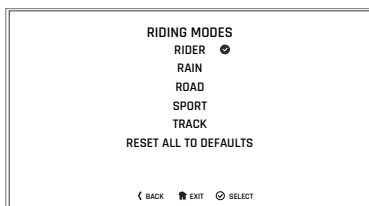

- ▼ Scroll down/up using the joystick to select the required riding mode. Press the joystick center to confirm.
- ▼ The relevant setting options for the selected riding mode are now shown.

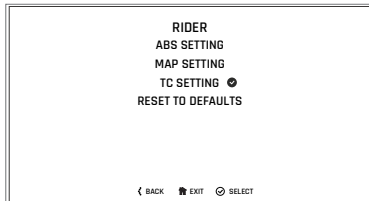



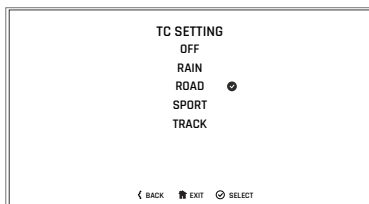

To change a setting, scroll down/up using the joystick until the required setting option is highlighted and press the joystick center to select.





## Riding Mode Configuration

Refer to the following table for the ABS, MAP and TC options available for each riding mode.

Riding Mode					
	RAIN 	ROAD 	SPOR T 	TRAC K 	RIDER 
<b>Anti-lock Braking System (ABS)</b>					
Road	●	●	●	○	●
Track	⊘	⊘	⊘	●	○
<b>MAP (Throttle Response)</b>					
Rain	●	○	⊘	○	○
Road	○	●	○	○	●
Sport	⊘	○	●	●	○
<b>Traction Control (TC)</b>					
Rain	●	○	⊘	○	○
Road	○	●	○	○	●
Sport	⊘	○	●	○	○
Track	⊘	⊘	⊘	●	○
Off	Via Menu	Via Menu	Via Menu	○	○
<b>Key</b>					
●	Standard (factory default setting)				
○	Selectable option				
⊘	Option not available				

## Bike Setup Menu

The Bike Setup menu allows configuration of the different features of the motorcycle.

To access the Bike Setup menu:

- ▼ From the MAIN MENU, push the joystick down and select BIKE SET UP.
- ▼ Press the joystick center to confirm.



## GENERAL INFORMATION

### Bike Setup - TSA (Shift Assist) (if equipped)

Triumph Shift Assist (TSA) triggers a momentary engine torque change to allow gears to engage, without closure of the throttle or operation of the clutch. This feature works for both up-shifts and down-shifts of gear.

The clutch must be used for stopping and pulling away.

TSA will not operate if the clutch is applied or if an up-shift is attempted by mistake when in 6th gear.

It is necessary to use a positive pedal force to make sure there is a smooth gear shift.

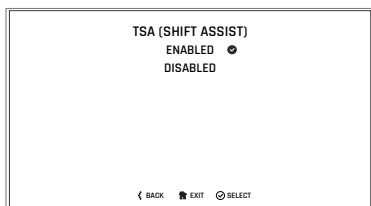

To enable/disable TSA:

- ▼ From the Bike Set Up menu, push the joystick down to select TSA (SHIFT ASSIST) and press the joystick to confirm.
- ▼ Push the joystick down/up to scroll between ENABLED and DISABLED.
- ▼ Press the joystick center to confirm the required selection.
- ▼ The display will then return to the BIKE SETUP menu.

For more information on Triumph Shift Assist (TSA), see page 125.

### Bike Setup - Turn Signals

The turn signals can be set to Auto Basic, Auto Advanced or Manual mode.

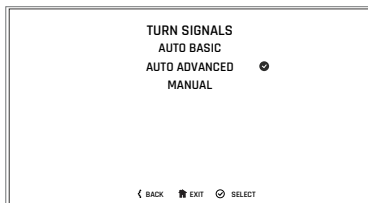

#### Selecting a Turn Signals Mode

To select the required turn signals mode:

- ▼ From the Bike Set Up menu, push the joystick down to select TURN SIGNALS and press the joystick center to confirm.
- ▼ Push the joystick down/up to scroll between AUTO BASIC, AUTO ADVANCED and MANUAL.
  - Auto Basic - The self-canceling function is on. The turn signals will activate for eight seconds and an additional 71 yards (65 meters).
  - Auto Advanced - The self-canceling function is on. A short press activates the turn signals for three flashes. A longer press activates the turn signals for eight seconds and an additional 71 yards (65 meters).
  - Manual - The self-canceling function is off. The turn signals must be manually canceled using the turn signal switch.
- ▼ Press the joystick center to confirm the required selection.
- ▼ The display will then return to the BIKE SETUP menu.

## Bike Setup - Traction Control (TC)

The Traction Control (TC) system can be temporarily disabled. The TC system cannot be permanently disabled, it will be automatically enabled when the ignition is turned off and then on again.

To disable or enable the TC system:

- ▼ From the BIKE SETUP menu, press the joystick center to select TC.
- ▼ Push the joystick down/up to scroll between ENABLED and DISABLED.

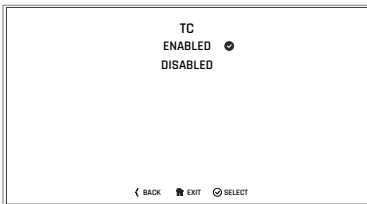

- ▼ Press the joystick center to select the required option.
- ▼ Once selected the display will return to the BIKE SET UP display.

## Bike Setup - Service

The service interval is set to a distance and/or time period.

To review the service interval:

- ▼ From the BIKE SET UP menu, push the joystick down to select SERVICE.
- ▼ Press the joystick center to display the SERVICE information.

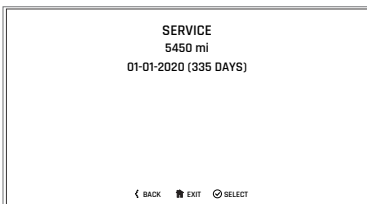

## Trip Setup

This menu allows the configuration of the trip meters.

To access the Trip Setup menu:

- ▼ From the MAIN MENU, push the joystick down and select TRIP SET UP.
- ▼ Press the joystick center to confirm.

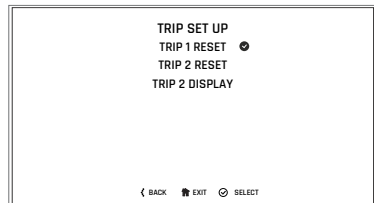

Selecting TRIP 1 RESET or TRIP 2 RESET allows the relevant trip meter to be configured manually or automatically. The set up procedure is the same for both trip meters.

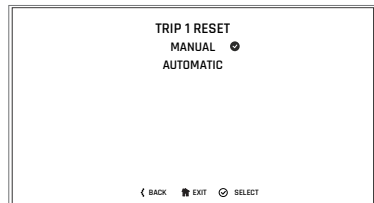

Manual reset will only reset the selected trip meter when the rider chooses to do so. For more information, see page 60.

Automatic reset will reset each trip meter after the ignition has been switched off for a set time. For more information, see page 60.

Trip meter 2 can be enabled or disabled. For more information, see page 61.

# GENERAL INFORMATION

## Trip Setup - Manual Reset

To set the trip computer to reset manually:

- ▼ From the TRIP SETUP menu, push the joystick down and then press the joystick center to select TRIP 1 RESET or TRIP 2 RESET.
- ▼ Push the joystick center to select MANUAL.



There are two options:

- ▼ RESET NOW AND CONTINUE - Resets all trip meter data in the relevant trip meter.
- ▼ CONTINUE WITHOUT RESET - Any trip meter data in the relevant trip meter will not be reset.

## Trip Setup - Automatic Reset

To set the trip computer to automatically reset:

- ▼ From the TRIP SETUP menu, push the joystick down/up and then press the joystick center to select TRIP 1 RESET or TRIP 2 RESET.
- ▼ Push the joystick down/up to select AUTOMATIC and then press the joystick center to confirm.
- ▼ Using the joystick down/up, choose the timer setting and press the joystick center to confirm the required time limit.
- ▼ The required time limit is then stored in the trip memory. A tick is shown to indicate the selected option.
- ▼ When the ignition is turned off, the trip meter is set to zero when the time period has elapsed.

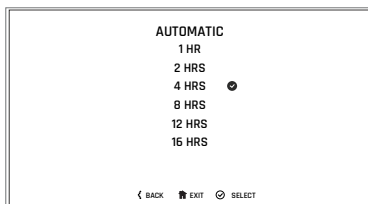

The following table shows two examples of the automatic trip reset functionality.

Ignition Turned Off	Selected Time Delay	Trip Meter Resets to Zero
10:30 hrs	4 HRS	14:30 hrs
18:00 hrs	16 HRS	10:00 hrs (next day)

## Trip 2 Display

Trip 2 meter can be enabled or disabled. If trip 2 meter is disabled, it will no longer be shown in the information tray.

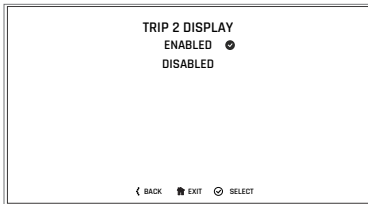

To enable or disable the Trip 2 meter:

- ▼ From the TRIP SET UP menu, push the joystick down/up to scroll to the TRIP 2 DISPLAY. Press the joystick center to confirm.
- ▼ Push the joystick down/up to scroll between ENABLED and DISABLED. Press the joystick center to confirm. A tick is shown to indicate the selected option.

## Display Setup Menu

The Display Setup menu allows configuration of the different display screen options.

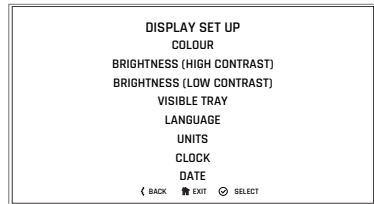

To access the Display Setup menu:

- ▼ From the MAIN MENU, push the joystick down and select DISPLAY SET UP. Press the joystick center to confirm.
- ▼ Select the required option from the list to access the relevant information.

## GENERAL INFORMATION

### Display Setup - Color

To select a different color for the display information:

- ▼ From the DISPLAY SET UP menu, push the joystick down/up to select COLOR.
- ▼ Press the joystick center to confirm.

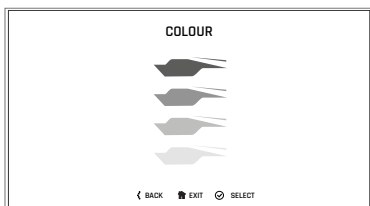

- ▼ Push the joystick down/up to scroll between the four different colored icons. There are four color options available; blue, green, yellow and white.
- ▼ Press the joystick center to select the required color.
- ▼ The new color is then applied to the instrument display for all styles. Press the HOME button to exit.

### Display Setup - Brightness

There are two brightness options to select from:

- ▼ High contrast - day time mode
- ▼ Low contrast - night time mode

To adjust the brightness:

- ▼ From the DISPLAY SET UP menu, push the joystick down to select BRIGHTNESS (HIGH CONTRAST) or BRIGHTNESS (LOW CONTRAST) menu.
- ▼ Press the joystick center to select the required menu.

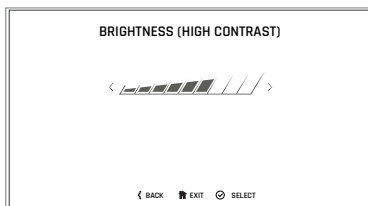

#### Brightness (High Contrast) Shown

- ▼ Push the joystick left/right to adjust the brightness.
- ▼ Press the joystick center to confirm the required level of brightness.
- ▼ Press the HOME button to return to the main display.

### NOTICE

In bright sunlight, low brightness settings will be overridden to make sure that the instruments can be viewed at all times.

## Display Setup - Visible Trays

The Visible Trays menu allows the selection of the items to be shown in the information tray.

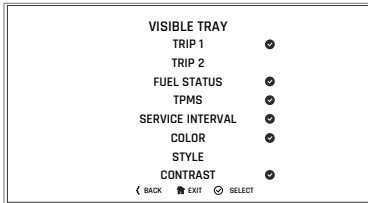

To select the Visible Tray menu:

- ▼ From the DISPLAY SET UP menu, push the joystick down to select the VISIBLE TRAY option.
- ▼ Press the joystick center to show the available options.
- ▼ Scroll the menu by moving the joystick down/up until the required option is highlighted.
- ▼ Press the joystick center to select/deselect the information trays.
- ▼ An information tray item with a tick next to it will be shown in the tray. An information tray item without a tick next to it will not be shown in the tray.

## Display Setup - Language

The Language menu allows the preferred language to be used as the instrument display language.



To select the required language for the instrument display:

- ▼ From the DISPLAY SET UP menu, push the joystick down to select the LANGUAGES option.
- ▼ Press the joystick center to confirm and display the available language options.
- ▼ Scroll the menu by pushing the joystick down/up until the required language option is highlighted.
- ▼ Press the joystick center to select/deselect the correct LANGUAGE. A tick is shown to indicate the selected option.
- ▼ Press the joystick center to confirm the language option.

## Display Setup - Units

The Units menu allows the selection of a preferred unit of measurement.

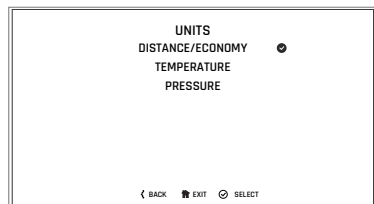

## GENERAL INFORMATION

To select the required units of measurement:

- ▼ From the DISPLAY SET UP menu, push the joystick down and select UNITS.
- ▼ Press the joystick center to confirm.

To change the unit of measurement:

- ▼ Push the joystick down/up to highlight the required option (DISTANCE/ECONOMY, TEMPERATURE or PRESSURE).
- ▼ Press the joystick center to select. A tick is shown to indicate the selected option.
- ▼ Push the joystick down/up to select the required unit of measurement.
- ▼ Press the joystick center to confirm. A tick is shown to indicate the selected option.

The options available are:

Economy:

- ▼ Miles & MPG (UK)
- ▼ Miles & MPG (US)
- ▼ KM & L/100KM
- ▼ KM & KM/L

TEMPERATURE:

- ▼ °C
- ▼ °F

PRESSURE:

- ▼ PSI
- ▼ BAR
- ▼ KPA

### Display Setup - Clock

The Clock menu allows the adjustment of the clock to be set to the local time.

To set the clock:

- ▼ From the Display Set Up menu, push the joystick down to select CLOCK and press the joystick center to confirm.
- ▼ Push the joystick down/up to select between either 12 Hr or 24 Hr clock and press the joystick center to confirm selection. A tick is shown to indicate the selected option.
- ▼ The clock will display in either 12 or 24 hour format. Once the clock format is set, the display will return to the CLOCK menu.

To set the time, push the joystick down/up to select HOURS or MINUTES.

To adjust the hour setting:

- ▼ Select HOURS on the display and press the joystick center. A tick will appear next to HOURS and the hour display will flash as shown below.
- ▼ Push the joystick down/up to set the hour. Press the joystick center to confirm.

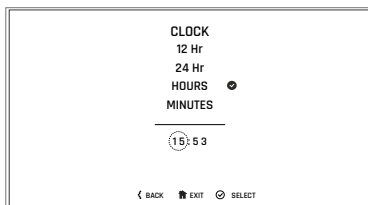



To adjust the minute setting:

To set the MINUTES repeat the procedure used to set the hour.

## Display Setup - Date

This function allows the date and date format to be adjusted.

To set the date format:

- ▼ From the DISPLAY SET UP menu, push the joystick down to select DATE and press the joystick center to confirm.
- ▼ Push the joystick down/up to select DATE FORMAT. Press the joystick center to confirm.



- ▼ Push the joystick down/up to select either of the date format options and press the joystick center to confirm selection. A tick is shown to indicate the selected option.
- ▼ Once the date format is set, the display will return to the DATE menu.

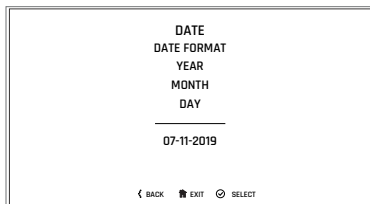

To set the date:

- ▼ From the DISPLAY SET UP menu, push the joystick down to select DATE and press the joystick center to confirm.
- ▼ Push the joystick down/up to select YEAR and press the joystick center to confirm. The YEAR display will flash.
- ▼ Push the joystick down/up to set the current year and then press the joystick center to confirm.
- ▼ To set the MONTH and DAY repeat the procedure used to set the year.

## Display Setup - Gear Shift Ind.

This menu allows the adjustment of the gear shift indicator.

The gear shift indicator changes the tachometer color to orange when the specified engine speed threshold is reached, indicating to shift gear.

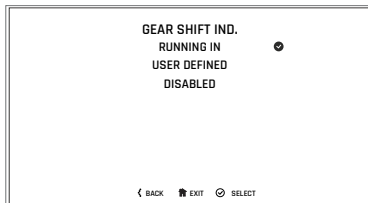

The engine speed threshold can be defined and reset, and the gear shift indicator can be disabled. Once the engine has been broken in (at 1,000 miles), the RUNNING IN option is replaced with a DEFAULT option.

## GENERAL INFORMATION

From the GEAR SHIFT IND. menu, push the joystick down to select USER DEFINED and press the joystick center to confirm.

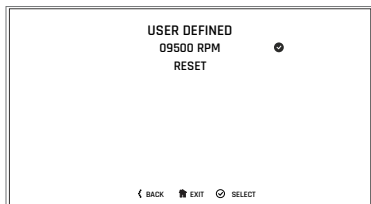

To adjust the engine speed threshold (RPM) for the gear shift indicator:

- ▼ Push the joystick left/right to select each individual number.
- ▼ Push the joystick down/up to change the number.
- ▼ Press the joystick center to confirm selection.
- ▼ Repeat this process with each individual number until the correct RPM number is shown.

To reset the gear shift indicator:

- ▼ Push the joystick down/up to select RESET and press the joystick center to confirm. This resets the RPM to 09500.

### Lap Timer

To set the lap timer option, the motorcycle must be stationary with the ignition turned to the ON position.

- ▼ Push the HOME button to show the MAIN MENU.
- ▼ Push the joystick down and then press joystick center to select LAP TIMER.



The options available are:

- ▼ START SESSION
- ▼ REVIEW (Review is available only if lap timer data is stored).

## Lap Timer - Start Session

This function allows the lap timer options to be set.

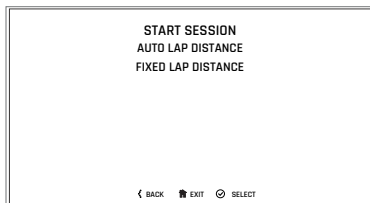

There are two options available:

- ▼ **AUTO LAP DISTANCE** - The motorcycle odometer is used to calculate the lap distance and average speed. The lap distance is accurate to +/-54.7 yards (50 meters).
- ▼ **FIXED LAP DISTANCE** - Allows the exact lap distance in yards or meters to be set. The lap timer uses the set distance to calculate a more accurate average speed, compared to Auto Lap Distance.

### AUTO LAP DISTANCE

To set the auto lap distance:

- ▼ Push the joystick down/up to select **AUTO LAP DISTANCE** and press the joystick center to start the lap timer session.

### FIXED LAP DISTANCE

To set the fixed lap distance:

- ▼ Push the joystick down/up to select **FIXED LAP DISTANCE** and press the joystick center. The **UNITS** and **SET DISTANCE** menus will be shown.

## UNITS



## SET DISTANCE

To manually input a measured distance:

- ▼ Using the joystick left/right and up/down, input the measured distance in meters or yards.
- ▼ Press the joystick center to confirm the selection.



To start the lap timer, see page 75.

## Lap Timer - Review

This function allows the rider to review any stored sessions (see page 66).

To select the lap timer - review menu the motorcycle must be stationary with the ignition turned to the ON position.

- ▼ Push the **HOME** button to show the **MAIN MENU**.
- ▼ Push joystick down and then press joystick center to select **LAP TIMER**.

## GENERAL INFORMATION

- ▼ Push joystick down to select the REVIEW menu.



- ▼ Push joystick center to display the stored sessions.
- ▼ Scroll the menu by moving the joystick up/down until the required session is highlighted.
- ▼ Press joystick center to select the required session and review the stored lap times using joystick up/down.
- ▼ Sessions are stored in time and date order.

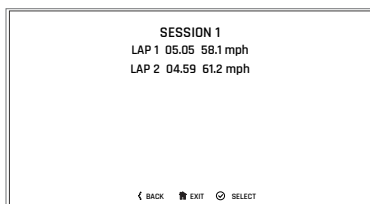

### NOTICE

The lap timer will store up to five sessions and up to 24 laps per session. Once this limit is reached, earlier sessions will be overwritten.

### Reset to Defaults

The Reset to Defaults option allows the Main Menu display items to be reset to the default setting.



To reset the Main Menu display items:

- ▼ From the Main Menu, push the joystick down and select RESET TO DEFAULTS.
- ▼ Push the joystick down/up to select CONFIRM or CANCEL. Press the joystick center to confirm the selection.
- ▼ CONFIRM - The following main menu settings and data will be reset to the factory default values - Riding Modes, Turn Signal Set Up, Trip Computers, Visible Trays, Language, Traction Control, Style, Display Brightness, Lap Timer settings and data.
- ▼ CANCEL - The main menu settings and data will remain unchanged and the display will return to the previous menu level.

## Information Tray

### WARNING

When the motorcycle is in motion, only attempt to switch between the information tray modes or reset the fuel information under the following conditions:

- At low speed
- In traffic free areas
- On straight and level roads or surfaces
- In good road and weather conditions.

Failure to follow the advice above may lead to loss of motorcycle control which could result in serious injury or death.

### NOTICE

To access the information tray, the warning messages must first be acknowledged (see page 70).

The information tray appears in the top section of the display screen for styles 01, 02 and 03. It appears on the left hand side of the display screen for style 04. It allows easy access to different motorcycle status information.

To view the different information tray items, push the joystick left/right until the required information tray item is shown.

The information tray contains the following information tray items:

- ▼ Warnings and Information Messages, see page 70
- ▼ Trip Meter, see page 70
- ▼ Fuel Consumption, see page 71
- ▼ Tire Pressure Monitoring System (TPMS) (if equipped), see page 71
- ▼ Service Interval, see page 72
- ▼ Color, see page 72
- ▼ Screen Contrast, see page 73
- ▼ Brightness, see page 74
- ▼ Style Select, see page 74
- ▼ Lap Timer, see page 75.

Different information tray items can be shown or hidden from the information tray. For further information, refer to page 63.

# GENERAL INFORMATION

## Warning Review

Any warnings and information messages are shown in the Warnings tray. An example is shown below.

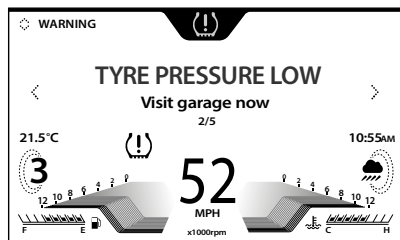

To view the warnings:

- ▼ Push the joystick down/up to scroll through the options until the warning review is shown.
- ▼ Push the joystick left/right to review each warning (if more than one). The warning counter will show the amount of warnings that are present.
- ▼ Push the joystick down/up to return to the information tray.

## Low Battery Warning

If items such as heated grips are mounted and are on with the engine at idle, over a period of time, the battery voltage may drop below a predetermined voltage and a warning message will be shown in the Warnings tray.

## Trip Meter

There are two trip meters that can be accessed and reset in the information tray.

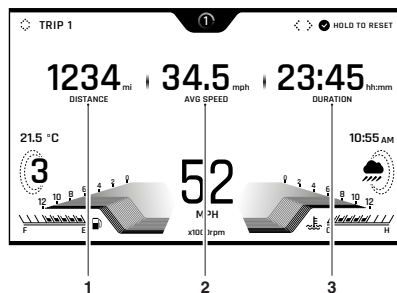

1. Distance traveled
2. Average speed
3. Duration of trip

To view a specific trip meter:

- ▼ Push the joystick left/right to scroll through the information tray items until TRIP 1 meter is shown.
- ▼ Select TRIP 1 or TRIP 2 by pushing the joystick down/up.

## NOTICE

TRIP 2 meter can be shown or hidden from the information tray. For more information, see page 61.

To reset a trip meter:

- ▼ Select the trip meter to be reset.
- ▼ Press and hold the joystick center for more than one second.
- ▼ The trip meter will then be reset.

The trip meter can also be reset from the Main menu, see page 60.

## Fuel Consumption

The Fuel Consumption information tray shows fuel consumption information.

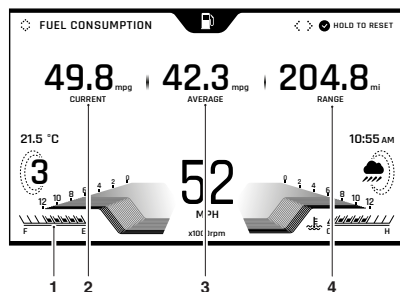

1. Fuel gage
2. Current fuel consumption
3. Average fuel consumption
4. Range to empty

After refueling, the fuel gage and range to empty information will be updated only while riding the motorcycle. Depending on the riding style, updating could take up to five minutes.

### Current Fuel Consumption

This is an indication of the fuel consumption at an instant in time. If the motorcycle is stationary, --- will be shown in the display area.

### Average Fuel Consumption

This is an indication of the average fuel consumption. After being reset the display will show dashes until 0.1 miles/km has been covered.

### Range to Empty

This is an indication of the predicted distance that can be traveled on the remaining fuel in the tank.

### Reset

To reset the average fuel consumption, press and hold the joystick center.

## Tire Pressure Monitoring System (TPMS) (if equipped)

### WARNING

Stop the motorcycle if the tire pressure warning light illuminates.

Do not ride the motorcycle until the tires have been checked and the tire pressures are at their recommended pressure when cold.

Failure to follow the advice above may lead to loss of motorcycle control which could result in serious injury or death.

The Tire Pressure Monitoring System (TPMS) information tray shows the front and rear tire pressures. For more information, see page 71.

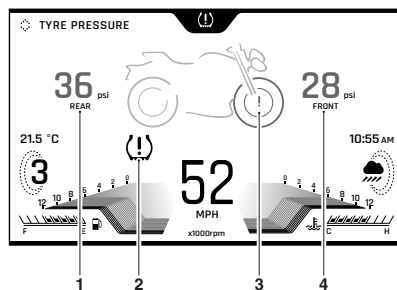

1. Rear tire pressure indicator
2. Tire pressure warning light
3. Low front tire pressure warning shown
4. Front tire pressure indicator

# GENERAL INFORMATION

## Tire Pressure Warning Light

The tire pressure warning light will only illuminate when the front or rear tire pressure is below the recommended pressure. It will not illuminate if the tire is over inflated.

## Front Tire Pressure Indicator

This shows the current front tire pressure.

## Rear Tire Pressure Indicator

This shows the current rear tire pressure.

## Low Tire Pressure

The front or rear tire will be highlighted on the motorcycle image to indicate that the tire pressure is below the recommended pressure.

## Service

The Service information tray shows the distance and days remaining before the next service is recommended.

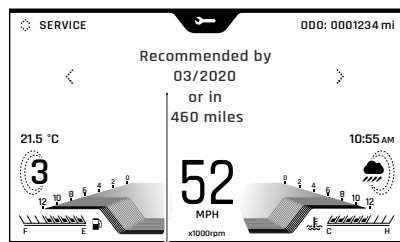

1

### 1. Service information

## Color

The Color information tray allows a different color to be applied to the current style. There are four color options available; blue, green, yellow and white.

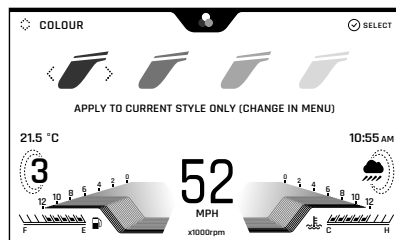

To apply a different color to the current style:

- ▼ Push the joystick left/right to select the required color.
- ▼ Press the joystick center to confirm the required color.
- ▼ The new color is then applied to the current style.
- ▼ To apply a color to all styles, see Display Set Up - Color.



## Screen Contrast

The Contrast information tray allows the display screen contrast to be adjusted.

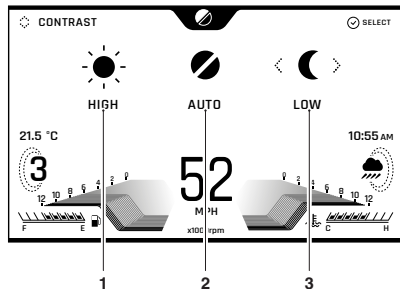

1. High contrast option
2. Auto contrast option
3. Low contrast option

There are three options available:

- ▼ HIGH - This option locks the display screen to the white background version of each display screen style for maximum visibility during the day.
- ▼ AUTO - This option uses the instrument light sensor to adjust the contrast to the most suitable setting. In bright sunlight, low brightness settings will be overridden to make sure the instruments can be viewed at all times.
- ▼ LOW - This option locks the display screen to the black background version of each display screen style for maximum visibility at night time.

To select an option:

- ▼ Push the joystick left/right to select the HIGH, AUTO or LOW contrast option and press the joystick center to confirm.
- ▼ If the rider defined brightness setting is suitable this will be used (see page 62).

### NOTICE

Do not cover the light sensor on the display screen as this will stop the screen brightness and contrast from working correctly.

# GENERAL INFORMATION

## Brightness

The Brightness information tray allows the brightness of the display screen to be adjusted. In bright sunlight, low brightness settings will be overridden to make sure that the instruments can be viewed at all times.

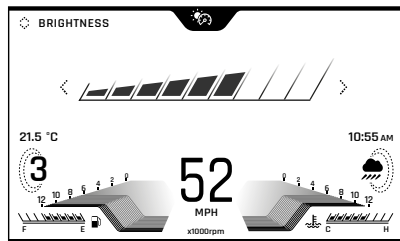

To adjust the brightness of the display screen:

- ▼ Push the joystick left/right to increase/decrease the level of brightness.
- ▼ Press the joystick center to confirm the required level of brightness.

### NOTICE

Do not cover the light sensor on the display screen as this will stop the screen brightness and contrast from working correctly.

## Style Select

The Style Select information tray allows a different style to be applied to the display screen.

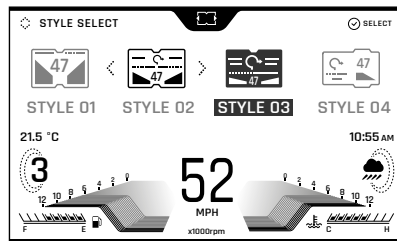

### Style Select Information Tray (Style 03 Selected)

To change the display screen style:

- ▼ Push the joystick left/right to select the required style and then press the joystick center to confirm.

## Lap Timer

The Lap Timer information tray allows a certain distance/lap to be timed and compared against a previously timed lap.

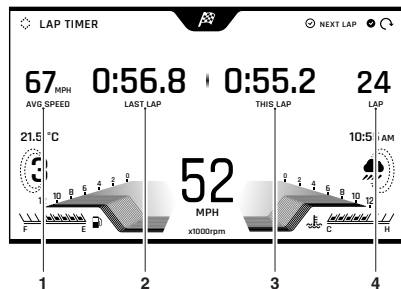

1. Average speed
2. Last lap time
3. This lap time
4. Number of lap

To start a lap:

- ▼ Briefly press the joystick down/up or center. The lap counter will start to count the first lap. This is shown as THIS LAP.
- ▼ Pressing the joystick down/up or center will start a new lap, and the previous lap's time and average speed will be shown in the information tray as LAST.LAP next to the new lap time.
- ▼ A long press (longer than two seconds) of the joystick down/up or center will stop the lap timer, clear the stored data and start a new lap time.
- ▼ The stored lap timer data is viewable from the Main Menu. For more information, see page 67.

## Instrument Panel Position Adjustment

### **! WARNING**

Operation of the motorcycle with an incorrectly adjusted instrument panel is dangerous.

Always adjust the instrument panel to provide sufficient vision of the instruments before riding the motorcycle.

An incorrectly adjusted instrument panel will result in loss of instrument vision when riding and may cause a distraction leading to loss of motorcycle control which could result in serious injury or death.

### **! WARNING**

Never attempt to clean or adjust the instrument panel while riding the motorcycle. Removal of the rider's hands from the handlebar while riding the motorcycle will diminish the ability of the rider to maintain control of the motorcycle.

Only attempt to clean or adjust the instrument panel while stationary.

Attempting to clean or adjust the instrument panel while riding the motorcycle may result in loss of motorcycle control which could result in serious injury or death.

## GENERAL INFORMATION

### **NOTICE**

Do not press directly onto the instrument panel display screen.

Only adjust the position of the instrument panel using the adjustment lever.

Pressing directly on the instrument panel display screen may damage the instrument panel.

The instrument panel can be adjusted to allow for improved visibility of the display screen.

Position the instrument panel to allow an unobstructed view of the display screen using the adjustment handle.

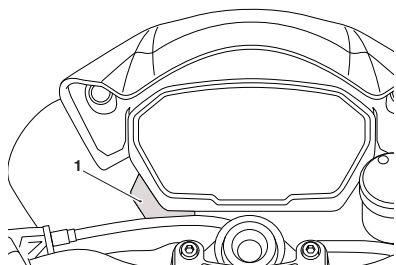

1. Adjustment handle

## Liquid Crystal Display (LCD) Instruments

### Table of Contents

Instrument Panel Layout.....	78
Warning Lights.....	79
Speedometer and Odometer .....	84
Tachometer .....	84
Gear Position Display .....	84
Coolant Temperature Gage .....	85
Fuel Gage .....	85
Instrument SCROLL/SET Buttons.....	86
Traction Control (TC) Disable.....	86
Clock.....	87
Service Interval Announcement (SIA).....	88
Gear Shift Lights .....	89
UnitS (Imperial, US or Metric) .....	90
Trip Meter.....	92
Lap Timer (if equipped).....	94
Riding Mode Selection.....	97
RAIN Mode.....	98
ROAD Mode .....	98
SPORT Mode (Street Triple R only).....	98
RIDER Mode (Street Triple R only).....	99
Setting the RIDER Mode Options .....	100
Selecting a Riding Mode – Motorcycle Stationary.....	102
Selecting a Riding Mode – Motorcycle Moving.....	103

# GENERAL INFORMATION

## Instrument Panel Layout

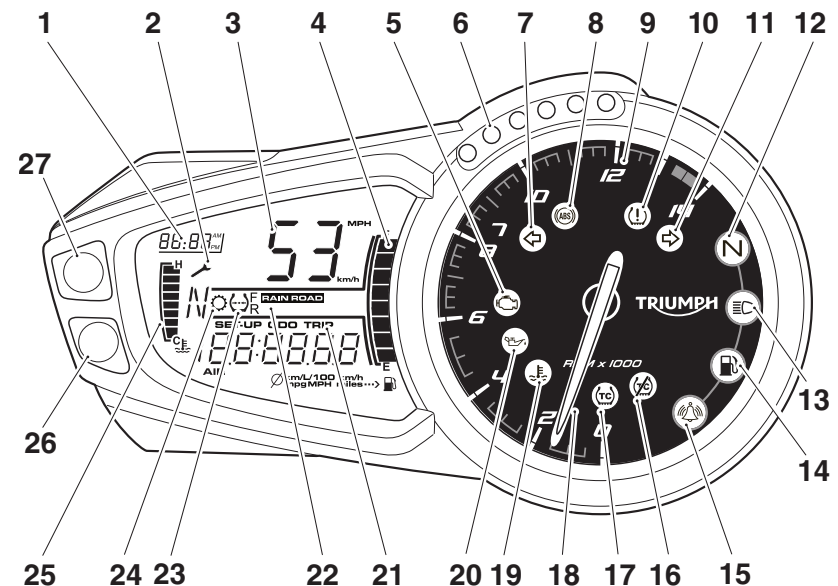

1. Clock
2. Service interval indicator
3. Speedometer
4. Fuel gage
5. Engine management Malfunction Indicator Light (MIL)
6. Gear shift lights
7. Left hand turn signal light
8. ABS warning light
9. Tachometer red zone
10. Tire pressure warning light (if equipped with Tire Pressure Monitoring System (TPMS))
11. Right hand turn signal light
12. Neutral indicator light
13. High beam indicator light
14. Low fuel level indicator light
15. Alarm/immobilizer status indicator light (alarm is an accessory kit)
16. Traction control (TC) disabled warning light
17. Traction control (TC) indicator light
18. Tachometer
19. High coolant temperature warning light
20. Low oil pressure warning light
21. Trip meter indicator
22. Riding modes indicator light
23. Tire pressure display (if Tire Pressure Monitoring System (TPMS) is equipped)
24. Gear position symbol
25. Coolant temperature display
26. SET Button
27. SCROLL Button

## Warning Lights

### Engine Management System Malfunction Indicator Light (MIL)



The Malfunction Indicator Light (MIL) for the engine management system illuminates when the ignition is switched ON (to indicate that it is working) but should not become illuminated when the engine is running.

If the engine is running and there is a fault with the engine management system the MIL will be illuminated and the general warning symbol will flash. In such circumstances, the engine management system may switch to 'limp-home' mode so that the journey may be completed, if the fault is not so severe that the engine will not run.

#### **WARNING**

Reduce speed and do not continue to ride for longer than is necessary with the Malfunction Indicator Light (MIL) illuminated. The fault may affect engine performance, exhaust emissions and fuel consumption.

The fault must be checked and rectified by a competent person with the specialist knowledge and technical understanding of motorcycles, such as an authorized Triumph dealer.

Reduced engine performance could cause a dangerous riding condition, leading to loss of motorcycle control which could result in serious injury or death.

If the MIL flashes when the ignition is switched ON contact an authorized Triumph dealer as soon as possible to have the situation rectified. In these circumstances the engine will not start.

### Low Oil Pressure Warning Light



With the engine running, if the engine oil pressure becomes dangerously low, the low oil pressure warning light will illuminate. The low oil pressure warning light will also illuminate if the ignition is switched ON without running the engine.

#### **NOTICE**

If the engine oil pressure is too low, the low oil pressure warning light will illuminate.

If the low oil pressure indicator remains on, stop the engine immediately and investigate the situation.

Running the engine with low oil pressure will cause severe engine damage.

### High Coolant Temperature Warning Light



With the engine running, if the engine coolant temperature becomes dangerously high, the high coolant temperature warning light will illuminate.

## GENERAL INFORMATION

### NOTICE

Stop the engine immediately if the high coolant temperature warning light illuminates. Do not restart the engine until the fault has been rectified.

Severe engine damage will result from running the engine when the high coolant temperature warning light is illuminated.

### Engine Immobilizer / Alarm Indicator Light



This motorcycle is equipped with an engine immobilizer which is activated when the ignition switch is turned to the OFF position.

#### Not Equipped With Alarm

When the ignition switch is turned to the OFF position, the engine immobilizer/alarm light will flash on and off for 24 hours to show that the engine immobilizer is on. When the ignition switch is turned to the ON position the engine immobilizer and the indicator light will be off.

If the indicator light remains on it indicates that the engine immobilizer has a malfunction that requires investigation. The fault must be checked and rectified by a competent person with the specialist knowledge and technical understanding of motorcycles, such as an authorized Triumph dealer.

#### Equipped With Alarm

The engine immobilizer/alarm light will only illuminate when the conditions described in the genuine Triumph accessory alarm instructions are met.

### Anti-lock Braking System (ABS) Warning Light



When the ignition switch is turned to the ON position, it is normal that the ABS warning light will flash on and off. The light will continue to flash after engine start-up until the motorcycle first reaches a speed exceeding 6 mph (10 km/h) when it will go off.

### NOTICE

Traction control will not function if there is a malfunction with the ABS. The warning lights for the ABS, traction control and the MIL will be illuminated.

The warning light should not illuminate again until the engine is restarted unless there is a fault.

If the warning light becomes illuminated at any time while riding it indicates that the ABS has a malfunction that requires investigation.



**⚠ WARNING**

If the Anti-lock Brake System (ABS) is not functioning, the brake system will continue to function as a non-ABS equipped brake system. Do not continue to ride for longer than is necessary with the ABS warning light illuminated.

The fault must be checked and rectified by a competent person with the specialist knowledge and technical understanding of motorcycles, such as an authorized Triumph dealer.

Braking too hard will cause the wheels to lock, leading to loss of motorcycle control which could result in serious injury or death.

**Traction Control (TC) Indicator Light**

The Traction Control (TC) indicator light is used to indicate that the traction control system is active and is working to limit rear wheel slip during periods of hard acceleration or under wet or slippery road conditions. Traction control will not function if there is a malfunction with the ABS. The warning lights for the ABS, traction control and the MIL will be illuminated.

**⚠ WARNING**

If the traction control is not functioning, care must be taken when accelerating and cornering on wet/slippy road surfaces to avoid rear wheel spin. Do not continue to ride for longer than is necessary with the engine management system Malfunction Indicator Light (MIL) and traction control warning lights illuminated.

The fault must be checked and rectified by a competent person with the specialist knowledge and technical understanding of motorcycles, such as an authorized Triumph dealer.

Hard acceleration and cornering may cause the rear wheel to spin, leading to loss of motorcycle control which could result in serious injury or death.

## GENERAL INFORMATION

If traction control is switched on:

- ▼ Under normal riding conditions the TC indicator light will remain off.
- ▼ The TC indicator light will flash rapidly when the traction control system is working to limit rear wheel slip during periods of hard acceleration or under wet or slippery road conditions.

If traction control is switched off:

- ▼ The TC indicator light will not illuminate. Instead the TC disabled warning light will be illuminated.

### Traction Control (TC) Disabled Warning Light



The Traction Control (TC) disabled warning light should not illuminate unless traction control is switched off or there is a malfunction.

If the warning light becomes illuminated while riding, it indicates that the traction control system has a malfunction that requires investigation. The fault must be checked and rectified by a competent person with the specialist knowledge and technical understanding of motorcycles, such as an authorized Triumph dealer.

### Turn signal Light



When the turn signal switch is turned to the left or right, the turn signal warning light will flash on and off at the same speed as the turn signals.

### Hazard Warning Lights

To turn the hazard warning lights on or off, press and release the hazard warning light switch.

The ignition must be switched ON for the hazard warning lights to function.

The hazard warning lights will remain on if the ignition is switched to the PARK position, until the hazard warning light switch is pressed again.

### High Beam Light



When the ignition is switched ON and the headlight dimmer switch is set to HIGH BEAM, the high beam warning light will illuminate.

### Low Fuel Warning Light



The low fuel indicator will illuminate when there are approximately 3.5 litres of fuel remaining in the tank.

## Neutral Light

# N

The neutral indicator light indicates when the transmission is in neutral (no gear selected). The indicator light will illuminate when the transmission is in neutral with the ignition switch in the ON position.

## Tire Pressure Warning Light

### **WARNING**

Stop the motorcycle if the tire pressure warning light illuminates.

Do not ride the motorcycle until the tires have been checked and the tire pressures are at their recommended pressure when cold.

Failure to follow the advice above may lead to loss of motorcycle control which could result in serious injury or death.

### **NOTICE**

The Tire Pressure Monitoring System (TPMS) is available as an accessory kit. It must be installed by your authorized Triumph dealer.

The TPMS display on the instruments will only be activated when the system has been installed.



The tire pressure warning light works in conjunction with the Tire Pressure Monitoring System (TPMS) see page 110.

The warning light will only illuminate when the front or rear tire pressure is below the recommended pressure. It will not illuminate if the tire is over inflated.

When the warning light is illuminated, the TPMS symbol indicating which is the deflated tire and its pressure will automatically be shown in the display area.

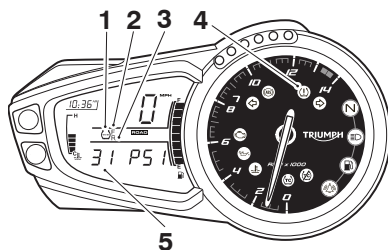

1. TPMS symbol
2. Front tire indicator
3. Rear tire indicator
4. Tire pressure warning light
5. Tire pressure

The tire pressure at which the warning light illuminates is temperature compensated to 68°F (20°C) but the numeric pressure display associated with it is not (see page 110). Even if the numeric display seems at or close to the standard tire pressure when the warning light is on, a low tire pressure is indicated and a puncture is the most likely cause.

## GENERAL INFORMATION

### Speedometer and Odometer

The speedometer indicates the road speed of the motorcycle.

The odometer shows the total distance that the motorcycle has travelled.

### Tachometer

#### NOTICE

Never allow engine speed to exceed the maximum engine speed as severe engine damage may result.

The tachometer shows the engine speed in revolutions per minute - rpm (r/min). At the end of the tachometer range there is the red zone.

Engine speeds in the red zone are above maximum recommended engine speed and are also above the range for best performance.

### Gear Position Display

The gear position display indicates which gear (one to six) has been engaged. When the transmission is in neutral (no gear selected), the display will show N.

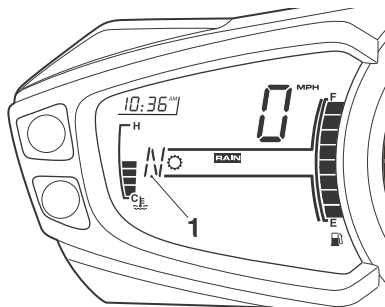

1. Gear position display (neutral position displayed)

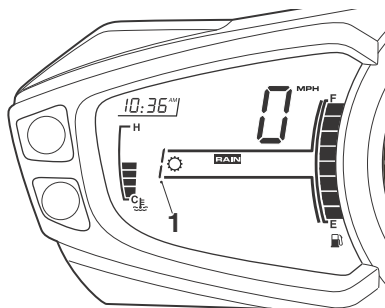

1. Gear position display (first gear displayed)

## Coolant Temperature Gage

The coolant temperature gage indicates the temperature of the engine coolant.

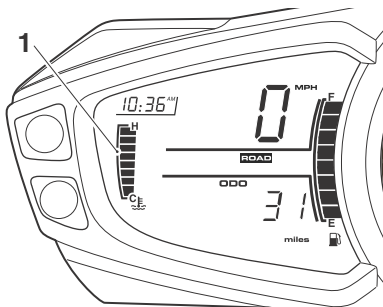

### 1. Coolant temperature gage

When the ignition is switched on, all eight bars of the display will be shown. When the engine is started from cold the display will show one bar. As the temperature increases more bars in the display will be shown. When the engine is started from hot the display will show the relevant number of bars, dependent on engine temperature.

The normal temperature range is between three and five bars.

If the coolant temperature becomes too high the display will show eight bars and will start to flash. The high coolant temperature light in the tachometer will also be illuminated.

## NOTICE

Stop the engine immediately if the high coolant temperature warning light illuminates. Do not restart the engine until the fault has been rectified.

Severe engine damage will result from running the engine when the high coolant temperature warning light is illuminated.

## Fuel Gage

The fuel gage indicates the amount of fuel in the tank.

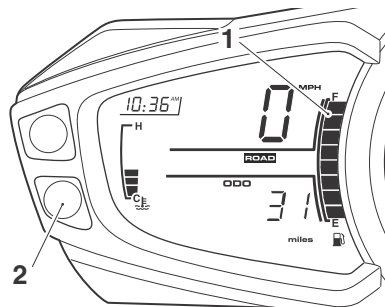

### 1. Fuel gage

### 2. SET Button

With the ignition switched on, the number of bars shown in the display indicates the level of fuel.

When the fuel tank is full all eight bars are displayed and when empty, no bars are displayed. Other gage markings indicate intermediate fuel levels between full and empty.

When two bars are displayed the low fuel warning light will illuminate. This indicates there are approximately 1.19 gallon (4.5 liters) of fuel remaining in the tank and you should refuel at the earliest opportunity. If a trip meter display is shown, the range to empty display can be selected by pressing and releasing the SET button until it is shown.

After refueling, the fuel gage and range to empty information will be updated only while riding the motorcycle. Depending on the riding style, updating could take up to five minutes.

# GENERAL INFORMATION

## Instrument SCROLL/SET Buttons

### SCROLL Button

When the SCROLL button is pressed and released it will scroll through the menu shown in the instrument display screen.

The SCROLL button is used to operate the following functions of the instruments:

- ▼ Set Up (SEtUP)
  - Traction Control (ttc), see page 86
  - Clock Adjustment (t-SEt), see page 87
  - Service Interval Announcement (SIA), see page 88
  - Gear Shift Lights (SHIFt), see page 89
  - Units (UnitS), see page 90.
- ▼ Return (REtURn)

### SET Button

When the SET button is pressed it will select the menu shown in the instrument display screen.

## Traction Control (TC) Disable

### WARNING

If the traction control is disabled, the motorcycle will handle as normal but without traction control.

In this situation accelerating too hard on wet/slippery road surfaces may cause the rear wheel to slip.

Failure to follow the advice above may lead to loss of motorcycle control which could result in serious injury or death.

It is possible to temporarily disable the Traction Control (TC) system. The TC system cannot be permanently disabled, it will be automatically enabled when the ignition is turned off and then on again.

### To Disable Traction Control

To access the traction control disable function:

- ▼ Press and release the SCROLL button until SEtUP is shown in the display screen then press the SET button.
- ▼ The display screen will show ttc.
- ▼ Press the set button and ON or OFF will be shown.
- ▼ Press and release the scroll button until OFF is shown in the display screen.

- ▼ Pressing the set button will disable the TC system; the message TTC OFF will be shown for 2 seconds, and the TC warning light will be illuminated.

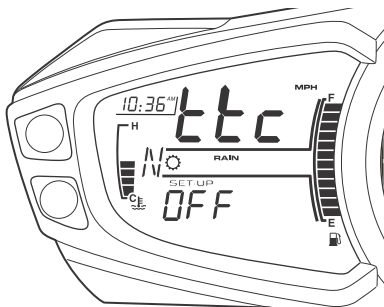

Traction Control Off Shown

### To Enable Traction Control

To enable the traction control system again:

- ▼ Repeat the traction control disable procedure and select ON.
- ▼ An alternative way to enable the TC is to turn the ignition off and on.

### Clock

#### **WARNING**

Do not attempt to set the clock while the motorcycle is in motion.

Stop the motorcycle to set the clock.

Failure to follow the advice above may lead to loss of motorcycle control which could result in serious injury or death.

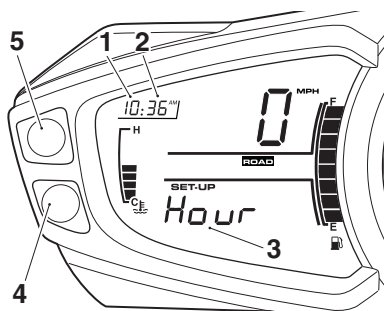

1. Hours
2. Minutes
3. Display screen (Hour selected for adjustment)
4. SET button
5. SCROLL button

### Adjusting the Clock - t-SET

To set the clock time format:

- ▼ Press and release the SCROLL button until SETUP is shown in the display screen. Press the SET button until t-SET is shown.
- ▼ Press the SET button again and either 24 Hr or 12 Hr clock format will be shown.

## GENERAL INFORMATION

- ▼ Press the SCROLL button to select the required clock display and then press the SET button. The hour display will start to flash and the word Hour is shown in the display screen.

To set the hour and minute display:

- ▼ Make sure that the hour display is still flashing and the word Hour is shown.
- ▼ Press the SCROLL button to change the setting. Each individual button press will change the setting by one digit. If the button is held, the display will continuously scroll through in single digit increments.
- ▼ When the correct hour display is shown, press the SET button. The minutes display will begin to flash and the word Min is shown in the display screen. The minutes display is adjusted in the same way as for the hours.
- ▼ Once both hours and minutes are correctly set, press the SET button to confirm and t-SEt will be shown in the display screen.
- ▼ Press and release the SCROLL button until REtURn is shown then press the SET button.

### Service Interval Announcement (SIA)

The Service Interval Announcement (SIA) shows the total distance that the motorcycle has remaining before a service is required.

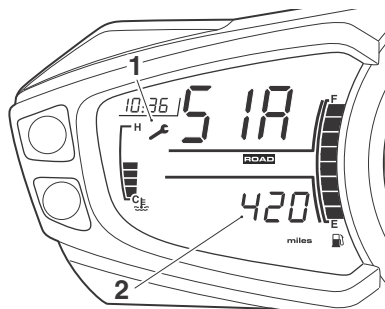

1. Service symbol
2. Remaining distance

When the remaining distance is 0 miles, the service symbol will remain on until the service has been carried out and the system has been reset by your authorized Triumph dealer.

If the service is overdue, the distance will be shown as a negative number.

When the ignition is switched on and the distance to the next service is 500 miles (800 km) or less, the service symbol will be shown for three seconds and the clock will show the distance remaining before the next service.



## Gear Shift Lights

**NOTICE**

The gear change lights will not operate below 3,500 rpm to avoid the lights operating at idle.

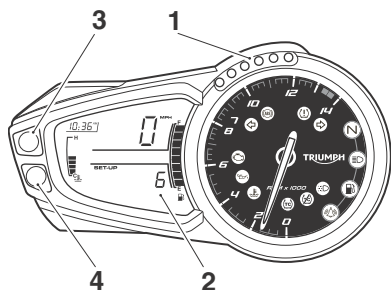

1. Gear shift lights
2. Display screen (6 mode shown)
3. SCROLL Button
4. SET Button

**Changing the Gear Shift Light Modes**

To change the gear shift light modes:

- ▼ Press and release the SCROLL button until SETUP is shown in the display screen then press the SET button.
- ▼ Press and release the SCROLL button until SHIFt is shown then press the SET button. The current mode will be shown and the corresponding gear shift lights will illuminate.
- ▼ Press and release the SCROLL button until the required gear shift light mode is shown then press the SET button. The display will scroll through in the following order:
  - 6 (6 LED mode);
  - 3 (3 LED mode);
  - SE (Sequential mode);
  - OFF (Gear shift lights off).

**NOTICE**

The motorcycle is delivered from the factory with the gear change light set to the 6 LED mode at 3,500 rpm.

When the gear shift light mode has been selected, the tachometer needle will move round to the current set position. The rpm will be shown in the display screen with the current set units flashing.

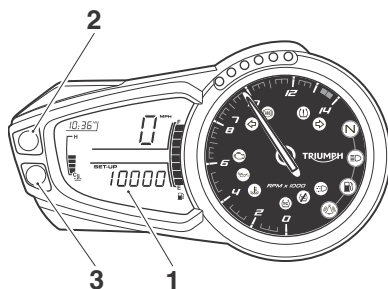

1. Current set units
2. SCROLL button
3. SET button

**Changing the Set Engine Speed**

To change the engine speed setting:

- ▼ Press the scroll button. Each individual press of the SCROLL button will increase the setting in increments of 500 rpm, up to the maximum rpm limit. When the maximum rpm limit is reached, the setting will return to 3,500 rpm.
- ▼ When the correct setting is shown, press the SET button to confirm the setting, SHIFt will be shown in the display screen and all the gear shift lights will flash.
- ▼ Press and release the SCROLL button until RETURn is shown in the display screen then press the SET button.

## GENERAL INFORMATION

### Setting the Gear Shift Lights to Off

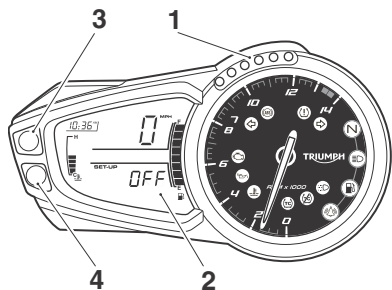

1. Gear shift lights
2. Display screen (OFF mode shown)
3. SCROLL Button
4. SET Button

To turn the gear shift lights to OFF:

- ▼ Press and release the SELECT button until OFF is shown then press the SET button.
- ▼ Press the SET button and SHIFt will be shown in the display screen.
- ▼ Press and release the SCROLL button until REtURn is shown in the display screen then press the SET button.

### UnitS (Imperial, US or Metric)

Units has four selectable display modes. Each display provides the following information:

#### mpg (Imperial gallons)

The speedometer and odometer will read in miles. The fuel consumption will be measured in imperial gallons.

#### mpg US (US gallons)

The speedometer and odometer will read in miles. The fuel consumption will be measured in US gallons.

#### L/100 km (Metric)

The speedometer and odometer will read in kilometers. The fuel consumption will be measured in liters of fuel per 100 km.

#### km/L (Metric)

The speedometer and odometer will read in kilometers. The fuel consumption will be measured in kilometers per liter of fuel.

## Changing the Units Display

### **⚠ WARNING**

Do not attempt to set the units while the motorcycle is in motion.

Stop the motorcycle to set the units.

Failure to follow the advice above may lead to loss of motorcycle control which could result in serious injury or death.

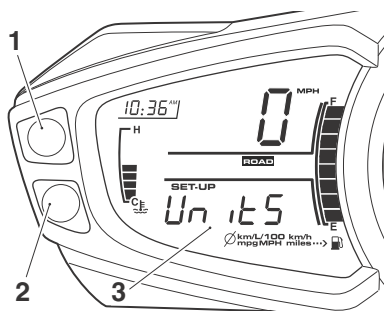

1. Scroll button
2. SET button
3. Display screen

To access the units display:

- ▼ Press and release the SCROLL button until SETUP is shown in the display screen then press the SET button.
- ▼ Press and release the SCROLL button until UnitS is shown then press the SET button.

- ▼ Press and release the SCROLL button until the required display is shown. The display will scroll through in the following order when pressing down on the SCROLL button (it will scroll through in the reverse order when pressing up on the SCROLL button):
  - mpg - Imperial gallons
  - mpg US - US gallons
  - L/100 km - Metric
  - km/L - Metric.

## Tire Pressure Units - only if TPMS is equipped

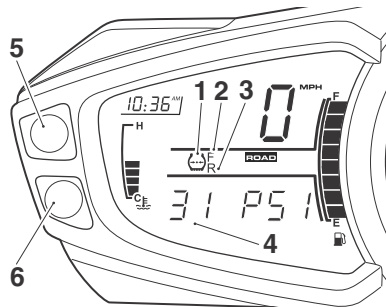

1. TPMS symbol
2. Front tire indicator
3. Rear tire indicator
4. Tire pressure display
5. Scroll button
6. Set button

To access the tire pressure display:

- ▼ Press and release the SCROLL button until SETUP is shown in the display screen.
- ▼ Press and release the SET button.
- ▼ Press and release the SCROLL button until UnitS is shown in the display screen.
- ▼ Press and release the SET button to select the pressure display.

## GENERAL INFORMATION

- ▼ Press and release the SCROLL button to scroll between BAR or PSI.
- ▼ Press and release the SET button to select either BAR or PSI.
- ▼ When the tire pressure monitoring system has been selected, -- PSI or bAR will be shown in the display screen until the motorcycle is traveling at a speed greater than 12 mph (20 km) and the tire pressure signal is received.

To exit the tire pressure display:

- ▼ Press and release the SCROLL button until REtURn is shown.
- ▼ Press and release the SET button to return to the TRIP screen

### Return

Select REtURn to return to the main display.

### Trip Meter

#### **WARNING**

Do not attempt to switch between the odometer and trip meter display modes or reset the trip meter while the motorcycle is in motion.

Stop the motorcycle to switch between the odometer and trip meter display modes or reset the trip meter.

Failure to follow the advice above may lead to loss of motorcycle control which could result in serious injury or death.

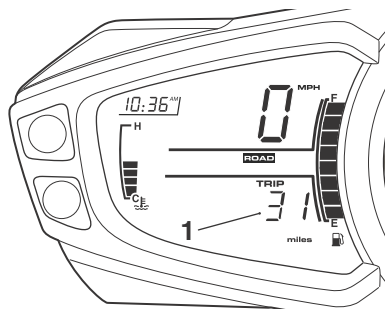

#### 1. Trip meter display

To access the trip meter information press and release the TRIP button on the left handlebar switch housing until the required display is shown.

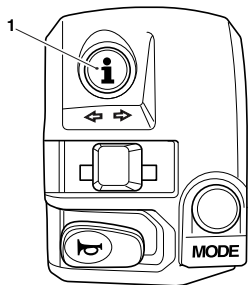

#### 1. TRIP button

The display will scroll through in the following order:

- ▼ Trip time
- ▼ Average fuel consumption
- ▼ Instantaneous fuel consumption
- ▼ Average speed
- ▼ Odometer
- ▼ Front Tire Pressure Display (if TPMS is equipped)
- ▼ Rear Tire Pressure Display (if TPMS is equipped)
- ▼ Trip distance
- ▼ Range to empty.

Each display provides the following information all calculated since the trip meter was last reset to zero:

#### Trip Time

The total time elapsed.

#### Average Fuel Consumption

An indication of the average fuel consumption. After being reset the display will show dashes until 0.1 miles/km has been covered.

#### Instantaneous Fuel Consumption

An indication of the fuel consumption at an instant in time.

#### Average Speed

The average speed is calculated from when the trip computer was last reset. After being reset the display will show dashes until 1 mile/km has been covered.

#### Odometer

The odometer shows the total distance that the motorcycle has traveled.

#### Front Tire Pressure Display

Displays the current front tire pressure.

#### Rear Tire Pressure Display

Displays the current rear tire pressure.

#### Trip Distance

The total trip distance traveled.

#### Range to Empty

This is an indication of the predicted distance that can be traveled on the remaining fuel in the tank.

#### Trip Meter Reset

To reset the trip meter, select and display the trip meter then press the TRIP button for one second. After one second, the trip meter will reset to zero.

### NOTICE

When the trip meter is reset to zero, the journey time, average fuel consumption and average speed will also be set to zero.

# GENERAL INFORMATION

## Lap Timer (if equipped)

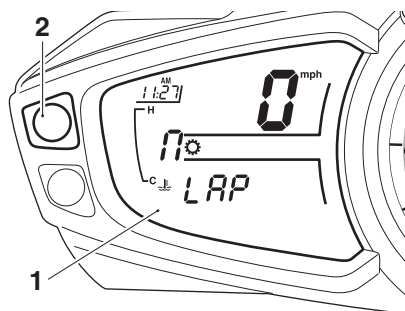

1. Display screen
2. Button A

The lap timer provides the following information: lap time, number of laps, average speed, maximum speed and distance traveled. Each display provides the following information:

### Lap Time

The elapsed time of the lap (the lap number will be displayed in the speedometer display). Information is recorded for each lap since the last reset. The lap timer will reset to zero after 100 minutes.

### Number of Laps

The number of recorded laps since the last reset is displayed. A maximum of 50 laps can be stored by the lap timer.

### Maximum Speed

The maximum speed achieved per lap and the lap number.

### Average Speed

The average speed per lap and the lap number.

### Distance Traveled

The distance traveled per lap and the lap number.

## Accessing the Lap Timer

### **⚠ WARNING**

Do not attempt to switch between lap timer display modes with the motorcycle in motion.

Stop the motorcycle to select the lap timer.

Failure to follow the advice above may lead to loss of motorcycle control which could result in serious injury or death.

To switch the lap timer on or off:

- ▼ Make sure the motorcycle is stationary and in neutral, turn the ignition to the ON position.
- ▼ Press and release button A until SET UP is shown in the display screen.
- ▼ Press button B.
- ▼ Press and release button A until Lap is shown then press button B. ON or OFF will flash in the display screen.
- ▼ Press button A to select the required display then press button B. Do not touch buttons A or B until Lap is shown in the display.
- ▼ Press and release button A until rEturN is shown then press button B. Trip 1 is then shown in the display screen.

The lap timer has two modes; data recording mode and data retrieval mode.

## Data Recording Mode

The data recording mode and the data retrieval mode will only operate when the lap timer (lap) is turned on.

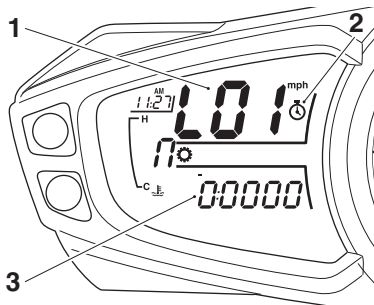

1. Lap display
2. Stopwatch icon
3. Lap time

To select the data recording mode:

- ▼ Turn the ignition to the ON position.
- ▼ Press and release button A until Lap is shown in the display screen then press button B.
- ▼ L01 and a stopwatch icon will be shown in the speedometer display, and the lap timer will be shown in the display screen.
- ▼ Pressing the starter button (with the engine running only) will start the lap timer. The display will show the lap time in minutes, seconds and hundredths of a second, and the stopwatch icon is on.

## New Lap Recording

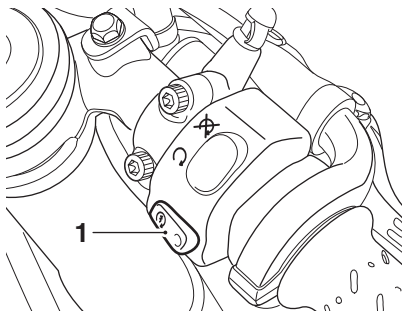

### 1. Starter button

At the end of the lap, pressing the starter button again will register the start of a new lap. The display will show the last lap time for five seconds then the new lap number for five seconds. After this time, the speedometer display will show the current lap number and the display screen will show the current lap time.

## GENERAL INFORMATION

### Data Retrieval Mode

The data retrieval mode cannot be accessed while the motorcycle is in motion.

The data retrieval mode can be accessed in one of two ways:

- ▼ With the ignition in the ON position, from the lap timer display, press button B.
- ▼ From the data recording mode, with the engine running and the motorcycle stationary, press the starter button for two seconds. This will return the display to the Lap display. Press button B.

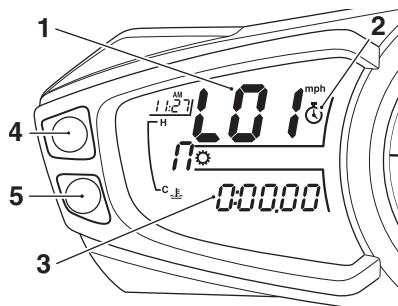

1. Lap number
2. Stopwatch icon
3. Lap timer
4. Button A
5. Button B

When the data retrieval mode is accessed, the lap time for the first lap will be shown. The lap number will be shown in the speedometer display position.

Press and release button A until the required lap (up to a maximum of 50 laps) is shown.

Press and release button B to scroll through the data available in the following order:

- ▼ Average Speed (per lap or total of all laps)
- ▼ Maximum Speed (per lap or maximum speed achieved)
- ▼ Distance Traveled (per lap or total of all laps)
- ▼ Lap Time.

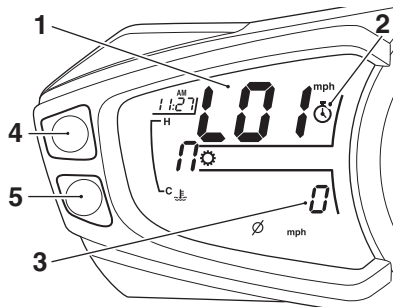

1. Lap number
2. Stopwatch icon
3. Data retrieval mode (average speed shown)
4. Button A
5. Button B

The speed and distance will be shown in miles or kilometers, according to the units shown by the speedometer.



## Lap Timer Reset

To reset the lap timer and exit the lap timer:

- ▼ Press button B for two seconds.
- ▼ After two seconds, the lap timer will reset and Lap will be shown in the display screen. This will delete the stored data for all stored laps.

To exit the data retrieval mode without resetting the lap timer:

- ▼ Press button A for two seconds. Lap will be shown in the display screen.
- ▼ Press and release button A to select the required display.

## Riding Mode Selection

### WARNING

After selecting a riding mode, operate the motorcycle in an area free from traffic to gain familiarity with the new settings.

Do not loan your motorcycle to anyone as they may change the riding mode settings from the one you are familiar with.

Failure to follow the advice above may lead to loss of motorcycle control which could result in serious injury or death.

Riding modes may be selected when the motorcycle is stationary or moving.

When the MODE button is pressed, the riding modes are displayed in the following sequence:

- ▼ RAIN Mode
- ▼ ROAD Mode
- ▼ SPORT Mode
- ▼ RIDER Mode.

There is a one second delay after pressing the MODE button between each of the modes to allow for further scrolling to take place.

The selected mode is automatically activated once the one second delay has elapsed, and the conditions for switching modes have been met.

The last selected riding mode will be remembered and activated when the ignition is switched ON.

## GENERAL INFORMATION

### RAIN Mode

The RAIN mode is predetermined and provides optimal ABS, MAP and TC settings for normal road use in rain conditions.

System Settings	
ABS	<b>Road</b> - Optimal ABS setting for road use.
MAP	<b>Rain</b> - Reduced throttle response when compared to the Road setting, for wet or slippery conditions.
TC	<b>Rain</b> - Optimal TC setting for road use in rain conditions, allows minimal rear wheel slip.

### ROAD Mode

The ROAD mode is predetermined and provides optimal ABS, MAP and TC settings for normal road use.

System Settings	
ABS	<b>Road</b> - Optimal ABS setting for road use.
MAP	<b>Road</b> - Standard throttle response.
TC	<b>Road</b> - Optimal TC setting for road use.

### SPORT Mode (Street Triple R only)

The SPORT mode provides optimal MAP, ABS and TTC settings for normal sport use.

System Settings	
ABS	<b>Road</b> - Optimal ABS setting for road use.
MAP	<b>Sport</b> - Increased throttle response when compared to the Road setting.
TC	<b>Sport</b> - Allows increased rear wheel slip when compared with the Road setting.

**RIDER Mode (Street Triple R only)**

The RIDER mode is fully adjustable and allows the rider to select MAP, ABS and TTC options to suit road conditions or personal preferences.

The MAP, ABS and TC options available for selection are as follows:

MAP Options	
<b>Rain</b>	Reduced throttle response when compared to the Road setting, for wet or slippery conditions.
<b>Road</b>	Standard throttle response.
<b>Sport</b>	Increased throttle response when compared to the Road setting.

ABS Options	
<b>Road</b>	Optimal ABS setting for road use.

TC Options	
<b>Rain</b>	Optimal TC setting for road use for wet or slippery conditions, allows minimal rear wheel slip.
<b>Road</b>	Optimal TC setting for road use, allows minimal rear wheel slip.
<b>Sport</b>	TC is set up for road use, allowing increased rear wheel slip when compared to the Road setting.
<b>Off</b>	TC is turned off. The TC disabled warning light will be illuminated (see page 82).

For details on setting the RIDER Mode options, see page 100.

## GENERAL INFORMATION

### Setting the RIDER Mode Options

During setup, TC can be activated or deactivated in the RIDER mode.

If the RIDER mode is currently selected, changes to the MAP, ABS and TC systems will become immediately active.

If the RAIN, ROAD or SPORT modes are selected the RIDER settings will not become active until the RIDER mode is selected (see page 97).

To set the RIDER mode options; with the motorcycle stationary and in neutral, turn the ignition to the ON position.

- ▼ Press and release the MODE button on the left handlebar switch housing until RIDER mode is selected.
- ▼ Press and hold the MODE button until MAP is shown in the display screen.

or alternatively:

- ▼ Press and release the SCROLL button until SETUP is shown in the display screen. Press the SET button to confirm.
- ▼ Press and release the SCROLL button until RIDER is shown in the lower instrument display, then press the SET button to confirm.

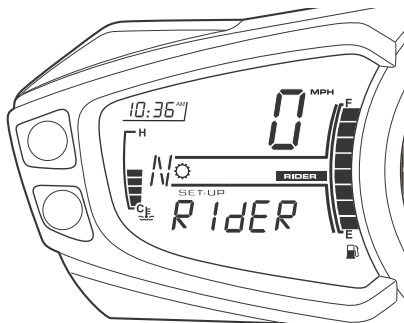

**RIDER Shown**

### MAP Options

- ▼ Press the SCROLL button and choose one of the available MAP options:
  - Rain
  - Road
  - Sport.

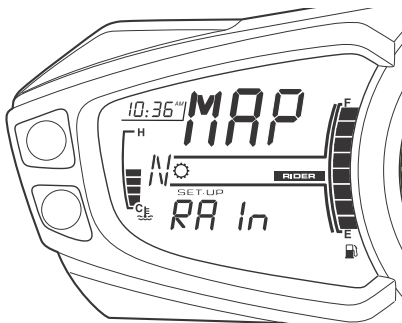

**Rain Option Shown**

- ▼ Press the SET button to confirm the selection.
- ▼ ABS is now shown in the display screen.

**ABS Options**

- ▼ Press the SCROLL button and choose one of the available ABS options:
  - Road

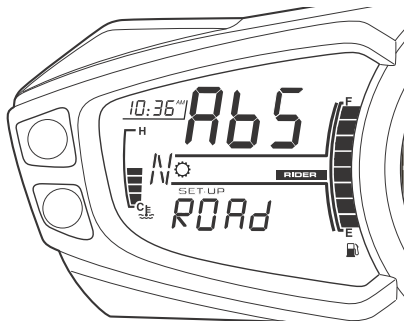
**Road Option Shown**

- ▼ Press the SET button to confirm the selection.
- ▼ TC is now shown in the display screen.

**TC Options**

- ▼ Press the SCROLL button and choose one of the available TC options:
  - Rain
  - Road
  - Off.

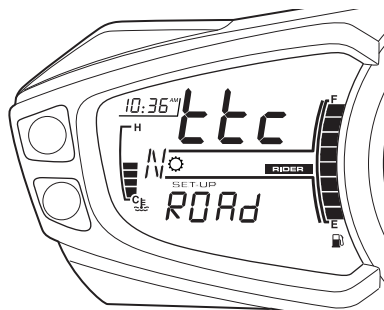
**Road Option Shown****⚠ WARNING**

If the traction control is disabled, the motorcycle will handle as normal but without traction control.

In this situation accelerating too hard on wet/slippy road surfaces may cause the rear wheel to slip.

Failure to follow the advice above may lead to loss of motorcycle control which could result in serious injury or death.

- ▼ Press the SET button to confirm the selection.

## GENERAL INFORMATION

- ▼ RiDER is now shown in the display.

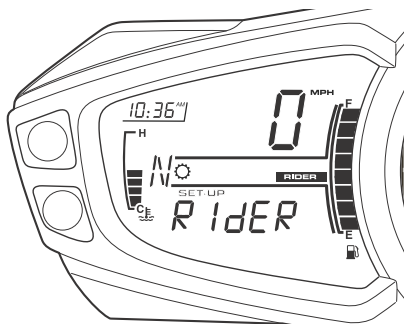

**RiDER Shown**

- ▼ Press the SET button and the REtURn screen is shown.

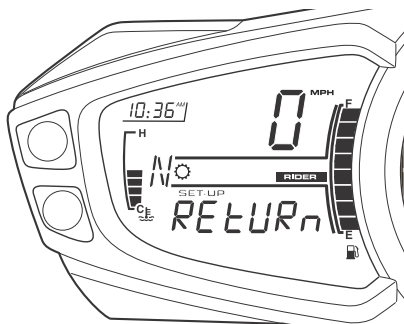

**REtURn Shown**

- ▼ Press the SET button to confirm.

- ▼ The trip screen and the current riding mode is shown.

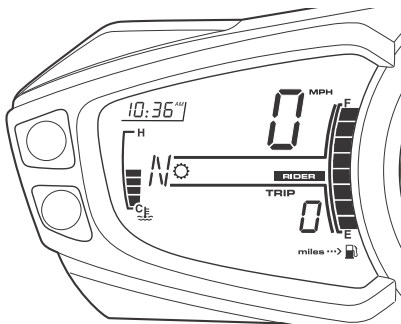

**Current Riding Mode**

- ▼ To select a riding mode, see page 97.

### Selecting a Riding Mode - Motorcycle Stationary

To select a riding mode when the motorcycle is stationary:

- ▼ Press and release the MODE button on the left handlebar switch housing until the required riding mode is flashing in the display.

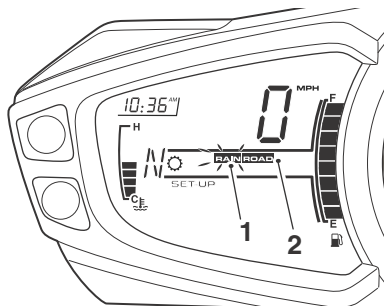

1. Selected riding mode (flashing)
2. Current (active) riding mode

- ▼ The selected riding mode is automatically activated one second after the MODE button is pressed, if the following conditions are met:

**With the Engine Off**

- ▼ The ignition is switched ON.
- ▼ The engine stop switch is in the RUN position.

**With the Engine Running**

- ▼ Neutral gear is selected or the clutch is pulled in.

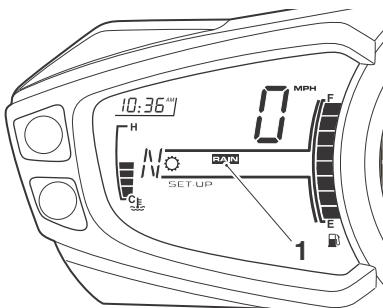
**1. Selected riding mode**

- ▼ Once the ABS, MAP and TTC settings have changed, the selected riding mode will be shown and the previous mode will no longer be shown.

**Selecting a Riding Mode – Motorcycle Moving****⚠ WARNING**

The selection of riding modes while the motorcycle is in motion requires the rider to allow the motorcycle to coast (motorcycle moving, engine running, throttle closed and no brakes applied) for a brief period of time.

Riding mode selection while the motorcycle is in motion should only be attempted:

- At low speed
- In traffic free areas
- On straight and level roads or surfaces
- In good road and weather conditions
- Where it is safe to allow the motorcycle to briefly coast.

Riding mode selection while the motorcycle is in motion **MUST NOT** be attempted:

- At high speeds
- While riding in traffic
- During cornering or on winding roads or surfaces
- On steeply inclined roads or surfaces
- In poor road/weather conditions
- Where it is unsafe to allow the motorcycle to coast.

Failure to follow the advice above may lead to loss of motorcycle control which could result in serious injury or death.

## GENERAL INFORMATION

To select a riding mode when the motorcycle is moving:

- ▼ Press and release the MODE button on the left handlebar switch housing until the required riding mode is flashing in the display.

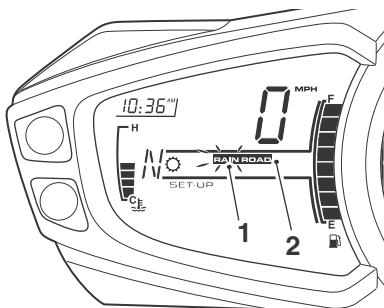

1. Selected riding mode (flashing)
2. Current (active) riding mode

- ▼ The selected riding mode is automatically activated if within 30 seconds of pressing the MODE button the following has been carried out simultaneously:
  - Throttle closed.
  - Brakes not applied (allow the motorcycle to coast).

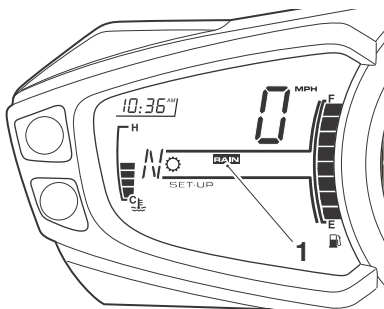

1. Selected riding mode

- ▼ Once the ABS, MAP and TTC settings have changed, the selected riding mode will be shown and the previous mode will no longer be shown.
- ▼ Resume riding as normal.
- ▼ If any one of the systems (ABS, MAP and TTC) fails to change to the settings specified by the selected riding mode, both the previous and the selected riding mode icons will flash.

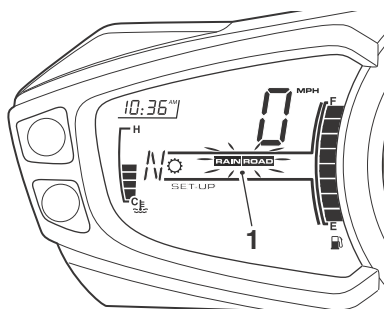

1. Incomplete mode change (flashing)

- ▼ The flashing of two riding mode icons together indicates that ABS, MAP and TTC settings specified by the selected riding mode have not been correctly selected. In this case the ABS, MIL or TTC warning light(s) may be illuminated depending on the current state of each system.

In the event of an incomplete riding mode change:

- ▼ Safely bring the motorcycle to a stop.
- ▼ Select Neutral.
- ▼ Turn the ignition OFF and then back ON again.
- ▼ Select the required riding mode.
- ▼ Restart the engine and continue riding.



**⚠ WARNING**

Do not stop the engine using the ignition switch or engine stop switch while the motorcycle is moving.

Always bring the motorcycle to a stop safely and engage Neutral gear prior to stopping the engine.

Stopping the engine by turning off the ignition or engine stop switch while the motorcycle is moving can lock the rear wheel leading to loss of motorcycle control which could result in serious injury or death.

**NOTICE**

The engine should normally be stopped by turning the ignition switch to the OFF position.

The engine stop switch is for emergency use only.

Do not leave the ignition switched on with the engine stopped. Electrical damage may result.

**NOTICE**

The engine should not be stopped by turning the ignition switch to the OFF position when the motorcycle is moving. The engine stop switch is for emergency use only.

Stopping the engine when the motorcycle is moving may cause damage to motorcycle components.

**NOTICE**

If the mode icons are not shown when the ignition switch is in the ON position, make sure that the engine stop switch is in the RUN position.

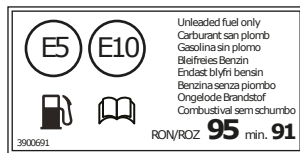
**Fuel****Fuel Grade**

Triumph motorcycles are designed to run on unleaded gasoline with a CLC or AKI octane rating (R+M)/2 of 87 or higher (91 RON). Federal regulations require that pumps delivering unleaded gasoline are marked 'UNLEADED' and that the Cost of Living Council (CLC) or Anti-Knock Index (AKI) octane rating is also displayed. These ratings are an average of the Research Octane Number (RON) and the Motor Octane Number (MON).

**Ethanol**

In Europe, Triumph motorcycles are compatible with Ethanol E5 and E10 (5% and 10% Ethanol) unleaded fuel.

In all other markets Ethanol up to E25 (25% Ethanol) may be used.

## GENERAL INFORMATION

### Engine Calibration

In certain circumstances engine calibration may be required. This should be completed by a competent person with the specialist knowledge and technical understanding of motorcycles, such as an authorized Triumph dealer.

#### NOTICE

The motorcycle can be permanently damaged if it is allowed to operate with the incorrect grade of fuel or incorrect engine calibration.

Always make sure the fuel used is of the correct grade and quality.

Damage caused by using the incorrect fuel or engine calibration is not considered a manufacturing defect and will not be covered under warranty.

#### NOTICE

The exhaust system for this motorcycle is equipped with a catalytic converter to help reduce exhaust emission levels.

Use of leaded fuel will damage the catalytic converter. In addition, the catalytic converter can be permanently damaged if the motorcycle is allowed to run out of fuel or if the fuel level is allowed to get very low.

Always make sure you have adequate fuel for your trip.

#### NOTICE

The use of leaded fuel is illegal in some countries, states or territories.

#### NOTICE

If 'knocking' or 'pinging' occurs at a steady engine speed under normal load, use a different brand of gasoline or gasoline which has a higher octane rating.

### Oxygenated Gasoline

To help in meeting clean air standards, some areas of the U.S. use oxygenated gasoline to help reduce harmful emissions. These gasolines are a blend of conventional gasoline and another compound such as alcohol. This Triumph motorcycle will give its best performance when using unleaded gasoline. However, the following should be used as a guide if you use any oxygenated fuels.

### Ethanol

Ethanol fuel is a mixture of 10% Ethanol and 90% gasoline and is often described under the names 'gasohol', 'Ethanol enhanced', or 'contains Ethanol'. This fuel may be used in your Triumph motorcycle.

### MTBE (Methyl Tertiary Butyl Ether)

The use of gasolines containing up to 15% MTBE (Methyl Tertiary Butyl Ether) is permitted in this Triumph motorcycle.

### Methanol

Fuels containing methanol should not be used as damage to components in the fuel system can be caused by contact with methanol.

#### **NOTICE**

Because of the generally higher volatility of oxygenated fuels, starting, engine response and fuel consumption may be adversely affected by their use. Should any of these difficulties be experienced, run the motorcycle on normal unleaded gasoline.

### Refueling

#### **⚠ WARNING**

To help reduce hazards associated with refueling, always observe the following fuel safety instructions:

- Gasoline (fuel) is highly flammable and can be explosive under certain conditions. When refueling, turn the ignition switch to the OFF position.
- Do not smoke.
- Do not use a mobile telephone.
- Make sure the refueling area is well ventilated and free from any source of flame or sparks. This includes any appliance with a pilot light.
- Pay full attention and remain alert while refueling.
- Never fill the tank until the fuel level rises into the filler neck. Heat from sunlight or other sources may cause the fuel to expand and overflow creating a fire hazard.
- After refueling always check that the fuel filler cap is correctly closed.
- Because gas (fuel) is highly flammable, any fuel leak or spillage, or any failure to observe the safety advice given above will lead to a fire hazard, which could cause damage to property, serious injury or death.

#### **NOTICE**

Avoid filling the tank in rainy or dusty conditions where airborne material can contaminate the fuel.

Contaminated fuel may cause damage to fuel system components.

## Fuel Tank Cap

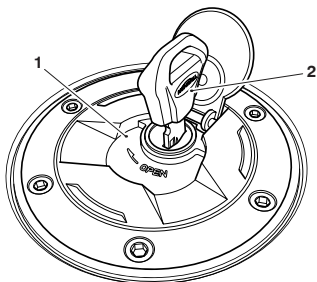

cbnm

1. Fuel tank cap
2. Key

To open the fuel tank cap, lift up the flap covering the lock. Insert the key into the lock and turn the key clockwise.

To close and lock the cap, push the cap down into place with the key inserted, until the lock clicks into place. Withdraw the key and close the key cover.

### NOTICE

Closing the cap without the key inserted will damage the cap, tank and lock mechanism.

## Filling the Fuel Tank

Fill the fuel tank slowly to help prevent spillage. Do not fill the tank to a level above the bottom of the filler neck. This will make sure there is enough air space to allow for fuel expansion if the fuel inside the tank expands through absorption of heat from the engine or from direct sunlight.

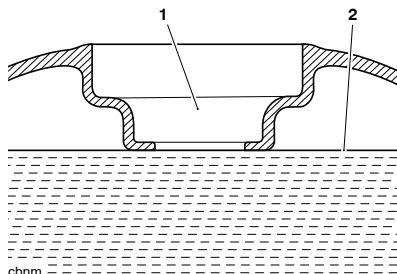

cbnm

1. Fuel filler neck
2. Maximum fuel level

After refueling always check that the fuel tank cap is correctly closed.

## Traction Control (TC)

### WARNING

The traction control and optimized cornering traction control systems are not a substitute for riding appropriately for the prevailing surface and weather conditions. The systems cannot prevent loss of traction due to; excessive speed when entering turns, accelerating at a sharp lean angle and braking.

Traction control or optimized cornering traction control cannot prevent the front wheel from slipping.

Failure to follow the advice above may lead to loss of motorcycle control which could result in serious injury or death.

Traction control helps to maintain traction when accelerating on wet/slippy road surfaces. If sensors detect that the rear wheel is losing traction (slipping), the traction control system will engage and alter the engine power until traction to the rear wheel has been restored. The traction control warning light will flash while it is engaged and the rider may notice a change to the sound of the engine.

Traction control will not function if there is a malfunction with the ABS. The warning lights for the ABS, traction control and the MIL will be illuminated.

## Traction Control Settings

### WARNING

Do not attempt to adjust the traction control settings while the motorcycle is in motion.

Adjusting the traction control settings while riding the motorcycle is dangerous.

Failure to follow the advice above may lead to loss of motorcycle control which could result in serious injury or death.

### WARNING

If the traction control is disabled, the motorcycle will handle as normal but without traction control.

In this situation accelerating too hard on wet/slippy road surfaces may cause the rear wheel to slip.

Failure to follow the advice above may lead to loss of motorcycle control which could result in serious injury or death.

The traction control can be set as described on page 53 for Street Triple RS models, or on page 86 for all other models.

If traction control is turned OFF, the TC disabled warning light will be illuminated (see page 47 or page 82).

The traction control defaults to ON after the ignition has been switched OFF and then switched ON again.

## GENERAL INFORMATION

### Tire Pressure Monitoring System (TPMS) (if equipped)



#### NOTICE

The Tire Pressure Monitoring System (TPMS) is available as an accessory kit. It must be installed by your authorized Triumph dealer.

The TPMS display on the instruments will only be activated when the system has been installed.

Tire pressure sensors are mounted to the front and rear wheels. These sensors measure the air pressure inside the tire and transmit pressure data to the instruments. These sensors will not transmit the data until the motorcycle is traveling at a speed greater than 12 mph (20 km/h). Two dashes will be shown in the display area until the tire pressure signal is received.

An adhesive label will be mounted to the wheel rim to indicate the position of the tire pressure sensor, which is near the valve.

### Tire Pressure Warning Light (if equipped with TPMS)

#### WARNING

Stop the motorcycle if the tire pressure warning light illuminates.

Do not ride the motorcycle until the tires have been checked and the tire pressures are at their recommended pressure when cold.

Failure to follow the advice above may lead to loss of motorcycle control which could result in serious injury or death.



The tire pressure warning light works in conjunction with the Tire Pressure Monitoring System, see page 110.

The warning light will only illuminate when the front or rear tire pressure is below the recommended pressure. It will not illuminate if the tire is over inflated.

## GENERAL INFORMATION

When the warning light is illuminated, the Tire Pressure display will show which tire is the deflated tire. It will also show the tire pressure.

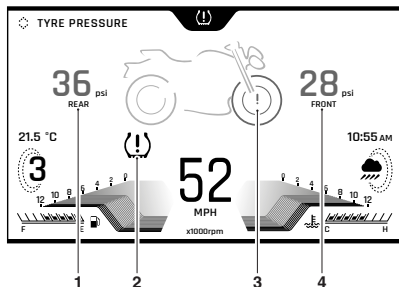

1. Rear tire pressure indicator
2. TPMS warning light
3. Low front tire pressure warning shown
4. Front tire pressure indicator

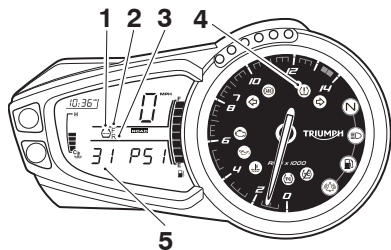

1. TPMS symbol
2. Front tire indicator
3. Rear tire indicator
4. Tire pressure warning light
5. Tire pressure

The tire pressure at which the warning light illuminates is temperature compensated to 68°F (20°C) but the numeric pressure display associated with it is not (see page 183). Even if the numeric display seems at or close to the standard tire pressure when the warning light is on, a low tire pressure is indicated and a puncture is the most likely cause.

### Tire Pressure Sensor Serial Number

The serial number for the tire pressure sensor is printed on a label attached to the sensor. This number may be required by your authorized Triumph dealer for service or diagnostics.

When the tire pressure monitoring system is being installed to the motorcycle, make sure that your authorized Triumph dealer records the serial numbers of the front and rear tire pressure sensors in the spaces provided below.

#### Front Tire Pressure Sensor

#### Rear Tire Pressure Sensor

**Tire Pressures****⚠ WARNING**

The daily check of tire pressures must not be excluded because of the installation of the Tire Pressure Monitoring System (TPMS).

The Tire Pressure Monitoring System (TPMS) is not to be used as a tire pressure gage when adjusting the tire pressures.

For correct tire pressures, always check the tire pressures when the tires are cold using an accurate tire pressure gage.

Use of the TPMS system to set inflation pressures may lead to incorrect tire pressures leading to loss of motorcycle control which could result in serious injury or death.

**NOTICE**

Do not use anti puncture fluid or any other item likely to obstruct air flow to the TPMS sensor's orifices. Any blockage to the air pressure orifice of the TPMS sensor during operation will cause the sensor to become blocked, causing irreparable damage to the TPMS sensor assembly.

Damage caused by the use of anti-puncture fluid or incorrect maintenance is not considered a manufacturing defect and will not be covered under warranty.

Always have the tires mounted by a competent person with the specialist knowledge and technical understanding of motorcycles, such as an authorized Triumph dealer. It is important to inform them that tire pressure sensors are installed on the wheels before they remove the tires.

The tire pressures shown on the instrument panel indicate the actual tire pressure at the time of selecting the display. This may differ from the inflation pressure set when the tires are cold because tires become warmer during riding, causing the air in the tire to expand and the pressure to increase. The cold inflation pressures specified by Triumph take account of this.

Only adjust tire pressures when the tires are cold using an accurate tire pressure gage (see --- MISSING LINK ---), and do not use the tire pressure display on the instruments.



## Replacement Tires

When replacing tires, contact a competent person with the specialist knowledge and technical understanding of motorcycles, such as an authorized Triumph dealer to mount your tires and make sure they are aware that tire pressure sensors are mounted to the wheels.

## Sensor Batteries

When the battery voltage in a pressure sensor is low, a message will be shown in the instrument display and the TPMS symbol or message will indicate which wheel sensor has the low battery voltage. If the batteries are completely flat, only dashes will be shown in the instrument display, the red TPMS warning light will be on and the TPMS symbol will flash continuously. Contact your authorized Triumph dealer to have the sensor replaced and the new serial number recorded in the spaces provided on page 111.

With the ignition switch turned to the ON position, if the TPMS symbol flashes continuously or the TPMS warning light remains on there is a fault with the TPMS system. Contact your authorized Triumph dealer to have the fault rectified.

## Side Stand

### WARNING

The motorcycle is equipped with an interlock system to prevent it from being ridden with the side stand in the down position.

Never attempt to ride with the side stand down or interfere with the interlock mechanism as this will cause a dangerous riding condition.

Failure to follow the advice above may lead to loss of motorcycle control which could result in serious injury or death.

### CAUTION

Do not lean, sit or climb on the motorcycle when it is supported on the side stand.

This may cause the motorcycle to fall over.

Failure to follow the advice above could result in minor to moderate injury.

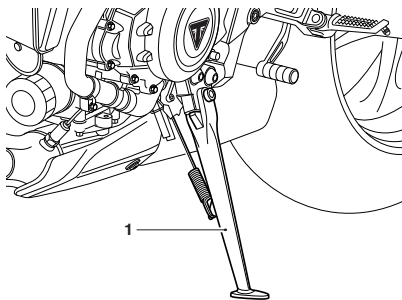

### 1. Side stand

The motorcycle is equipped with a side stand on which the motorcycle can be parked.

## GENERAL INFORMATION

When using the side stand, always turn the handlebars fully to the left and leave the motorcycle in first gear.

Whenever the side stand is used, before riding, always make sure that the side stand is fully up after first sitting on the motorcycle.

For instructions on safe parking, refer to the How to Ride the Motorcycle section.

### Seats

#### Seat Care

#### NOTICE

To prevent damage to the seat or seat cover, care must be taken not to drop the seat. Do not lean the seat against the motorcycle or any surface which may damage the seat or seat cover. Instead, place the seat, with the seat cover facing upwards, on a clean, flat surface which is covered with a soft cloth.

Do not place any item on the seat which may cause damage or staining to the seat cover.

See page 202 for seat cleaning information.

#### Rider's Seat

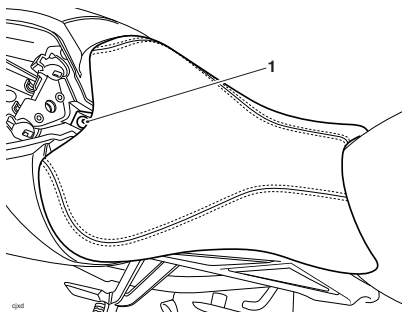

#### 1. Rider's seat fastener

To remove the rider's seat:

- ▼ Remove the passenger seat or seat cowl (see page 115).
- ▼ Remove the fastener located to the rear of the padding. This will allow the rider's seat to slide up and rearwards for complete removal from the motorcycle.

To re-install the seat:

- ▼ Engage the seat's tongue under the fuel tank.
- ▼ Install and tighten the fastener to 80 lbf in (9 Nm).
- ▼ Re-install the passenger seat or seat cowl (see page 115).

#### **WARNING**

Never ride the motorcycle with the fixings loose or removed, as the rider's seat will not be secure and can move.

The rider's seat is only correctly retained and supported when the fixings are correctly tightened.

A loose or detached seat may lead to loss of motorcycle control which could result in serious injury or death.

## Passenger Seat and Seat Cowl

### NOTICE

This section applies to both the passenger seat and the seat cowl. The seat cowl is installed to certain models only, or is available as an accessory.

The passenger seat lock is located on the left hand side of the rear bodywork, in line with the footrest mounting rail.

### Removal

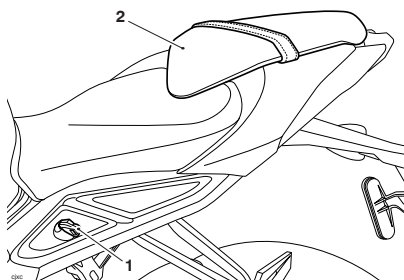

1. Seat lock
2. Passenger seat

To remove the passenger seat:

- ▼ Insert the ignition key into the seat lock and turn it counter-clockwise while pressing down on the front of the seat. This will release the passenger seat from its lock.
- ▼ Slide the passenger seat forward for complete removal from the motorcycle.

### WARNING

Never ride the motorcycle with the passenger seat detached or removed.

To prevent detachment of the seat during riding, after fitting always grasp the seat and pull firmly upwards.

If the seat is not correctly secured it will detach from the lock. A loose or detached seat may lead to loss of motorcycle control which could result in serious injury or death.

### Reinstall

To re-install the passenger seat:

- ▼ Engage the seat's tongue under the bracket.
- ▼ Align the locating peg to the lock and press down engaging the seat lock. An audible click can be heard when the seat is fully engaged in its lock.

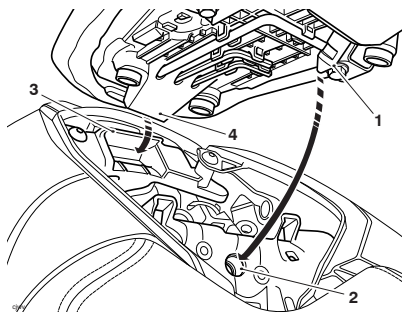

1. Locating peg
2. Lock
3. Bracket
4. Tongue

# GENERAL INFORMATION

## Owner's Handbook and Tool Kit

### Owner's Handbook

The Owner's Handbook is located under the passenger seat.

### Tool Kit

The tool kit is located on the underside of the passenger seat.

### Street Triple S (40.2 cu in (660 cc))

The tool kit includes a:

- ▼ Screwdriver
- ▼ Rear suspension unit spring preload adjustment tool (not stored in tool kit)
- ▼ Extension handle (not stored in tool kit)
- ▼ 0.16 in (4 mm) Allen key
- ▼ 0.20 in (5 mm) Allen key.

### Street Triple R - LRH

The tool kit includes a:

- ▼ Screwdriver
- ▼ Rear suspension unit spring preload adjustment tool (not stored in tool kit)
- ▼ Extension handle (not stored in tool kit)
- ▼ 0.16 in (4 mm) Allen key
- ▼ 0.20 in (5 mm) Allen key
- ▼ Front fork adjuster tool

### Street Triple R

The tool kit includes a:

- ▼ Screwdriver
- ▼ 0.16 in (4 mm) Allen key
- ▼ 0.20 in (5 mm) Allen key
- ▼ Front fork adjuster tool.

### Street Triple RS

The tool kit includes a:

- ▼ Screwdriver
- ▼ 0.12 in (3 mm) Allen key
- ▼ 0.16 in (4 mm) Allen key
- ▼ 0.20 in (5 mm) Allen key
- ▼ Front fork adjuster tool.

## Universal Serial Bus (USB) Socket

### WARNING

The USB socket is not waterproof unless the waterproof cap is installed. Do not connect electronic devices while it is raining.

Water in the USB socket could lead to an electrical problem resulting in motorcycle damage, which may affect the handling, stability or other aspect of the motorcycle operation.

Failure to follow the advice above may lead to loss of motorcycle control which could result in serious injury or death.

### NOTICE

Do not leave the ignition switch in the ON position unless the engine is running as this will discharge the battery.

## GENERAL INFORMATION

### NOTICE

Make sure that all electronic devices and cables are safely secured under the seat when riding.

Make sure there is sufficient space surrounding any electronic devices for the seat to close without causing any damage to the electronic device or the motorcycle.

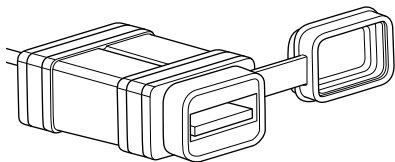

### USB Port Socket

The Universal Serial Bus (USB) socket allows a 5 Volt USB connection for charging electronic devices such as mobile phones, cameras and GPS devices. Loads up to a maximum of two Amps can be connected to the USB socket.

To access the USB socket:

- ▼ Remove the passenger seat or seat cowl, see page 115.

- ▼ The USB socket is located on the right hand side, adjacent to the seat lock.

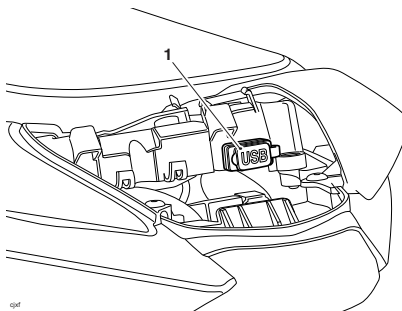

### USB Port Socket

- ▼ Remove the cap.
- ▼ Plug the relevant USB adapter cable into the socket.

### NOTICE

Adapter cables are not supplied with the motorcycle.

# GENERAL INFORMATION

## Breaking-In



Breaking-in is the name given to the process that occurs during the first hours of a new vehicle's operation.

In particular, internal friction in the engine will be higher when components are new. Later on, when continued operation of the engine has ensured that the components have 'bedded in', this internal friction will be greatly reduced.

A period of careful breaking-in will ensure lower exhaust emissions, and will optimize performance, fuel economy and longevity of the engine and other motorcycle components.

During the first 600 miles (1,000 km):

- ▼ Do not use full throttle
- ▼ Avoid high engine speeds at all times
- ▼ Avoid riding at one constant engine speed, whether fast or slow, for a long period of time
- ▼ Avoid aggressive starts, stops, and rapid accelerations, except in an emergency
- ▼ Do not ride at speeds greater than 3/4 of maximum engine speed.

From 600 to 1,000 miles (1,000 to 1,500 km):

- ▼ Engine speed can gradually be increased to the maximum engine speed for short periods.

Both during and after breaking-in has been completed:

- ▼ Do not over-rev the engine when cold
- ▼ Do not lug the engine. Always downshift before the engine begins to 'struggle'
- ▼ Do not ride with engine speeds unnecessarily high. Shifting up a gear helps reduce fuel consumption, reduces noise and helps to protect the environment.

## Daily Safety Checks



### WARNING

Failure to perform these checks every day before you ride may result in serious motorcycle damage or an accident causing serious injury or death.

Check the following items each day before you ride. The time required is minimal, and these checks will help ensure a safe, reliable ride.

If any irregularities are found during these checks, refer to the Maintenance and Adjustment section or see your authorized Triumph dealer for the action required to return the motorcycle to a safe operating condition.

Check the following:

**Fuel:** Adequate supply in tank, no fuel leaks (page 105).

**Engine Oil:** Correct level on dipstick. Add correct specification oil as required. No leaks from the engine or oil cooler (page 147).

**Drive Chain:** Correct adjustment (page 157).

**Tires/Wheels:** Correct inflation pressures (when cold). Tread depth/wear, tire/wheel damage, punctures etc. (page 182).

**Nuts, Bolts, Fasteners:** Visually check that steering and suspension components, axles, and all controls are properly tightened or fastened. Inspect all areas for loose/damaged fasteners.

**Steering Action:** Smooth but not loose from lock to lock. No binding of any of the control cables (page 169).

**Brakes:** Pull the brake lever and push the brake pedal to check for correct resistance. Investigate any lever/pedal where the travel is excessive before meeting resistance, or if either control feels spongy in operation (page 160).

**Front Brake Pads:** Check that the correct amount of friction material is remaining on all the brake pads (page 160).

**Brake Fluid Levels:** No brake fluid leakage. Brake fluid levels must be between the MAX and MIN marks on both reservoirs (page 163).

**Front Forks:** Smooth action. No leaks from fork seals (page 171).

**Throttle:** Make sure that the throttle grip returns to the idle position without sticking (page 28).

**Clutch:** Smooth operation and correct cable free play (page 154).

**Coolant:** No coolant leakage. Check the coolant level in the expansion tank (when the engine is cold) (page 151).

**Electrical Equipment:** All lights and the horn function correctly (page 193).

**Engine Stop:** Stop switch turns the engine off (page 122).

**Stand:** Returns to the fully up position by spring tension. Return springs not weak or damaged (page 113).

This page intentionally left blank



**Table of Contents**

Stopping the Engine.....	122
Starting the Engine.....	122
Moving Off .....	123
Shifting Gears .....	124
Triumph Shift Assist (TSA) (if equipped).....	125
Braking.....	126
Parking.....	129
Considerations for High Speed Operation .....	131

# HOW TO RIDE THE MOTORCYCLE

## Stopping the Engine

### NOTICE

The engine should normally be stopped by turning the ignition switch to the OFF position.

The engine stop switch is for emergency use only.

Do not leave the ignition switched on with the engine stopped. Electrical damage may result.

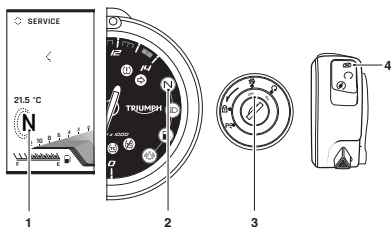

1. Neutral indicator (Street Triple RS only)
2. Neutral indicator (all models except Street Triple RS)
3. OFF position on the ignition switch
4. STOP position on the engine start/stop switch

To stop the engine:

- ▶ Close the throttle completely.
- ▶ Select neutral.
- ▶ Turn the ignition switch to the OFF position.
- ▶ Select first gear.
- ▶ Support the motorcycle on a firm, level surface with the side stand.
- ▶ Lock the steering.

## Starting the Engine

### ⚠ DANGER

Never start the engine or run the engine in a confined area.

Always operate the motorcycle in the open air or in an area with adequate ventilation.

Exhaust fumes are poisonous and will cause loss of consciousness and death within a short period of time.

### NOTICE

Do not operate the starter continuously for more than five seconds as the starter motor will overheat and the battery will become discharged.

Wait 15 seconds between each operation of the starter to allow for cooling and recovery of battery power.

Do not let the engine idle for long periods as this may lead to overheating which will cause damage to the engine.

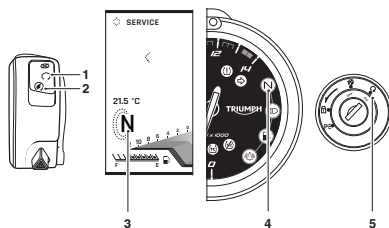

1. RUN position on the engine start/stop switch
2. START position on the engine start/stop switch
3. Neutral indicator (Street Triple RS only)
4. Neutral indicator (all models except Street Triple RS)
5. ON position on the ignition switch

To start the engine:

- ▼ Check that the stop switch is in the RUN position.
- ▼ Make sure the transmission is in neutral.
- ▼ Pull the clutch lever fully into the handlebar.
- ▼ Turn the ignition switch to the ON position.

## NOTICE

When the ignition is switched on, the tachometer needle will quickly sweep from zero to maximum and then return to zero (LCD instruments only). The instrument warning lights will illuminate and will then go off (except those which normally remain on until the engine starts - see page 42 for TFT instruments and page 79 for LCD instruments). It is not necessary to wait for the needle to return to zero (LCD instruments only) before starting the engine.

A transponder is installed within the key to turn off the engine immobilizer. To make sure the immobilizer functions correctly, always have only one of the ignition keys near the ignition switch. Having two ignition keys near the switch may interrupt the signal between the transponder and the engine immobilizer. In this situation the engine immobilizer will remain active until one of the ignition keys is removed.

- ▼ Leaving the throttle fully closed, push the starter button until the engine starts.
- ▼ Slowly release the clutch lever.

## NOTICE

The low oil pressure warning light should go out shortly after the engine starts.

If the low oil pressure warning light remains on after starting the engine, stop the engine immediately and investigate the cause.

Running the engine with low oil pressure will cause severe engine damage.

- ▼ The motorcycle is equipped with starter lockout switches. The switches prevent the electric starter from operating when a gear is engaged with the side stand down.
- ▼ If the side stand is extended while the engine is running, and the transmission is not in neutral then the engine will stop regardless of clutch position.

## Moving Off

- ▼ Pull in the clutch lever and select first gear.
- ▼ Open the throttle a little and let out the clutch lever slowly.
- ▼ As the clutch starts to engage, open the throttle a little more, allowing enough engine speed to avoid stalling.

# HOW TO RIDE THE MOTORCYCLE

## Shifting Gears

### **⚠ WARNING**

Take care to avoid opening the throttle too far or too fast in any of the lower gears as this can lead to the front wheel lifting from the ground (pulling a 'wheelie') and to the rear tire breaking traction (wheel spin).

Always open the throttle cautiously, particularly if you are unfamiliar with the motorcycle.

Pulling a 'wheelie' or loss of traction may lead to loss of motorcycle control which could result in serious injury or death.

### **⚠ WARNING**

Do not shift to a lower gear at speeds that will cause excessive engine rpm (r/min).

Shifting down should be done such that low engine speeds will be ensured.

Shifting to a lower gear at high speed can lock the rear wheel leading to loss of motorcycle control which could result in serious injury or death.

For models equipped with Triumph Shift Assist (TSA), see page 125.

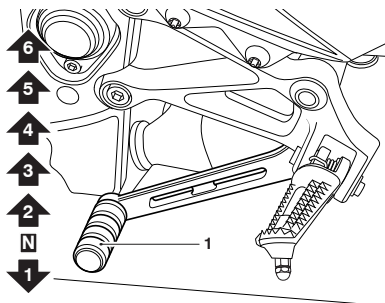

### 1. Gear shift pedal

To shift gear:

- ▼ Close the throttle while pulling in the clutch lever.
- ▼ Shift into the next higher or lower gear.
- ▼ Open the throttle part way, while releasing the clutch lever.
- ▼ Always use the clutch when shifting gear.

### **NOTICE**

The gear shift mechanism is the 'positive stop' type. This means that, for each movement of the gear shift pedal, you can only select each gear, one after the other, in ascending or descending order.

## Triumph Shift Assist (TSA) (if equipped)

### NOTICE

In the event of a TSA system fault when riding, the TSA system will be disabled.

Use the clutch to shift gears in the normal way otherwise damage to the engine or gear box may occur.

Contact a competent person with the specialist knowledge and technical understanding of motorcycles, such as an authorized Triumph dealer.

### NOTICE

Shifting gears must be completed with a quick and forceful pedal movement, making sure that the pedal moves through its full range of travel.

Always take care when shifting gears. After a gear shift, the pedal must be fully released before another gear shift can be made.

Incorrect gear shifts can cause damage to the engine and transmission.

Triumph Shift Assist (TSA) adjusts the engine torque to allow gears to engage, without closure of the throttle twist grip or operation of the clutch.

TSA is not an automatic system for shifting gears. Gears must be selected and shifted in the normal way using the gear pedal as described on page 124.

TSA works for both up shifts and down shifts of gear. The clutch must be used for stopping and pulling away. The clutch must be used when selecting any gear from neutral, and also when selecting neutral from any other gear.

Triumph Shift Assist will not operate if:

- ▼ The clutch is applied.
- ▼ An up shift is attempted by mistake when in 6th gear.
- ▼ A down shift is attempted by mistake when in 1st gear.
- ▼ An up shift is attempted at very low engine speeds.
- ▼ A down shift is attempted at very high engine speeds.
- ▼ An up shift is attempted during overrun.
- ▼ The vehicle speed limiter is active.
- ▼ Cruise control is active.
- ▼ Traction control is operating.
- ▼ If the previous gear has not fully engaged.
- ▼ The throttle is changed during a shift.

If TSA does not operate, the clutch can be used to shift gears in the normal way.

For more information on enabling and disabling the TSA functionality, see page 58.

# HOW TO RIDE THE MOTORCYCLE

## Braking

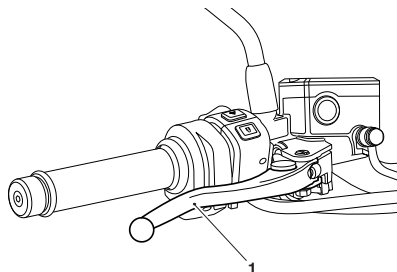

1. Front brake lever

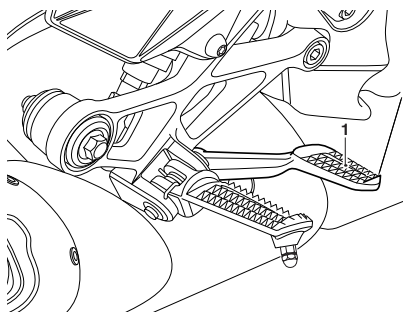

1. Rear brake pedal

### **! WARNING**

WHEN BRAKING, OBSERVE THE FOLLOWING:

- Close the throttle completely, leaving the clutch engaged to allow the engine to help slow down the motorcycle.
- Shift down one gear at a time such that the transmission is in first gear when the motorcycle comes to a complete stop.
- When stopping, always apply both brakes at the same time. Normally the front brake should be applied a little more than the rear.
- Shift down or fully disengage the clutch as necessary to keep the engine from stalling.
- Never lock the brakes, as this may cause loss of control of the motorcycle.

Failure to follow the advice above could result in serious injury or death.

### **! WARNING**

For emergency braking, disregard down shifting, and concentrate on applying the front and rear brakes as hard as possible without skidding.

Riders should practice emergency braking in a traffic-free area.

Triumph strongly recommends that all riders take a course of instruction, which includes advice on safe brake operation. Incorrect brake technique may lead to loss of motorcycle control which could result in serious injury or death.

## WARNING

For your safety, always exercise extreme caution when braking, accelerating or turning as any improper action can cause loss of motorcycle control and an accident. Independent use of the front or rear brakes reduces overall braking performance. Extreme braking may cause either wheel to lock, reducing control of the motorcycle and causing an accident (see ABS warnings).

When possible, reduce speed or brake before entering a turn as closing the throttle or braking in mid-turn may cause wheel slip leading to loss of control.

When riding in wet or rainy conditions, or on loose surfaces, the ability to maneuver and stop will be reduced. All of your actions should be smooth under these conditions. Sudden acceleration, braking or turning may cause loss of motorcycle control.

Failure to follow the advice above may lead to loss of motorcycle control which could result in serious injury or death.

## WARNING

When descending a long, steep gradient or mountain pass, make use of the engine's braking effect by down shifting and use both front and rear brakes intermittently.

Continuous brake application or use of the rear brake only can overheat the brakes and reduce their effectiveness.

Failure to follow the advice above may lead to loss of motorcycle control which could result in serious injury or death.

## WARNING

Riding with your foot on the brake pedal or your hands on the brake lever may actuate the brake light, giving a false indication to other road users.

It may also overheat the brake, reducing braking effectiveness.

Failure to follow the advice above may lead to loss of motorcycle control which could result in serious injury or death.

## WARNING

Do not coast with the engine switched off, and do not tow the motorcycle.

The transmission is pressure lubricated only when the engine is running.

Inadequate lubrication may cause damage or seizure of the transmission, which may lead to loss of motorcycle control which could result in serious injury or death.

# HOW TO RIDE THE MOTORCYCLE

## ABS (Anti-Lock Brake System)

### WARNING

The ABS function attempts to maximize the chances of keeping the motorcycle under control when braking. The potentially shorter braking distances, ABS allows under certain conditions, are not a substitute for good riding practice.

Always ride within the legal speed limit.

Never ride without due care and attention and always reduce speed in consideration of weather, road and traffic conditions.

Under some circumstances it is possible that a motorcycle equipped with ABS may require a longer stopping distance.

Take care when cornering. If the brakes are applied in a corner, ABS will not be able to counteract the weight and momentum of the motorcycle.

Failure to follow the advice above may lead to loss of motorcycle control which could result in serious injury or death.

## ABS Warning Light



When the ignition switch is turned to the ON position, it is normal for the ABS warning light to flash on and off, see page 43 for Street Triple R, Street Triple R - LRH and Street Triple RS models or page 43 for Street Triple S (40.2 cu in (660 cc)) models. If the ABS warning light is constantly illuminated it indicates that the ABS function is not available because:

- ▼ The ABS has been disabled by the rider, see page 53 Street Triple R, Street Triple R - LRH and Street Triple RS models.
- ▼ The ABS has a malfunction that requires investigation.

If the indicator light becomes illuminated while riding, it indicates that the ABS has a malfunction that requires investigation.

### WARNING

If the Anti-lock Brake System (ABS) is not functioning, the brake system will continue to function as a non-ABS equipped brake system. Reduce speed and do not continue to ride for longer than is necessary with the ABS warning light illuminated.

The fault must be checked and rectified by a competent person with the specialist knowledge and technical understanding of motorcycles, such as an authorized Triumph dealer.

Braking too hard will cause the wheels to lock, leading to loss of motorcycle control which could result in serious injury or death.



## WARNING

ABS operates by comparing the relative speed of the front and rear wheels.

Use of non-recommended tires can affect wheel speed and cause the ABS not to operate. Always install recommended tires.

Failure to follow the advice above may lead to loss of motorcycle control which could result in serious injury or death.

## NOTICE

The ABS operation may feel like a harder pedal pressure or a pulsation of the brake lever and pedal.

The ABS is not an integrated braking system and does not control both the front and rear brake at the same time so this pulsation may be felt in the lever, the pedal or both.

The ABS may be activated by sudden upward or downward changes in the road surface.

## NOTICE

The ABS warning light will illuminate when the rear wheel is driven at high speed for more than 30 seconds when the motorcycle is on a stand. This reaction is normal.

When the ignition is switched off and the motorcycle is restarted, the warning light will illuminate until the motorcycle reaches a speed exceeding 19 mph (30 km/h).

## Parking

### WARNING

Gasoline is extremely flammable and can be explosive under certain conditions.

If parking inside a garage or other structure, be sure it is well ventilated and the motorcycle is not close to any source of flame or sparks. This includes any appliance with a pilot light.

Failure to follow the above advice may cause a fire resulting in damage to property, serious injury or death.

### CAUTION

The engine and exhaust system will be hot after riding.

DO NOT park where pedestrians and children are likely to touch the motorcycle.

Touching any part of the engine or exhaust system when hot could result in minor or moderate injury.

# HOW TO RIDE THE MOTORCYCLE

## ⚠ CAUTION

Take care when parking on soft ground or on a steeply inclined surface.

Parking under these conditions may cause the motorcycle to fall over which could result in minor or moderate injury.

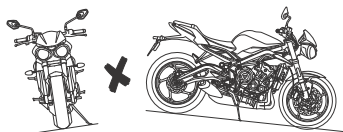
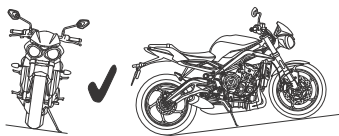

- ▼ On a lateral (sideways) incline, always park such that the incline naturally pushes the motorcycle towards the side stand.
- ▼ Do not park on a lateral (sideways) incline of greater than 6° and never park facing downhill.
- ▼ Do not leave the switch in the P position for long periods of time as this will discharge the battery.
- ▼ When parking near traffic at night, or when parking in a location where parking lights are required by law, leave the tail, license plate and position lights on by turning the ignition switch to P (PARK).

To park the motorcycle:

- ▼ Select neutral and turn the ignition switch to the OFF position.
- ▼ Select first gear.
- ▼ Lock the steering to help prevent theft.
- ▼ Always park on a firm, level surface to prevent the motorcycle from falling. This is particularly important when parking off-road.
- ▼ When parking on a hill, always park facing uphill to prevent the motorcycle from rolling off the stand. Engage first gear to prevent the motorcycle from moving.

## Considerations for High Speed Operation

### WARNING

This motorcycle should be operated within the legal speed limits for the particular road traveled.

Riding a motorcycle at high speeds can be dangerous since the time available to react to a hazard is greatly reduced at high speeds.

Always reduce speed in potentially hazardous driving conditions such as bad weather or heavy traffic.

Failure to follow the advice above may lead to loss of motorcycle control which could result in serious injury or death.

### WARNING

Only operate this motorcycle at high speed in closed-course, on-road competition or on closed-course racetracks.

High speed operation should only then be attempted by riders who have been instructed in the techniques necessary for high speed riding and are familiar with the motorcycle's characteristics in all conditions.

High speed operation in any other circumstances is dangerous and may lead to loss of motorcycle control which could result in serious injury or death.

### WARNING

The handling characteristics of a motorcycle at high speed may vary from those you are familiar with at legal road speeds.

Do not attempt high speed operation unless you have received sufficient training and have the required skills.

Failure to follow the advice above may lead to loss of motorcycle control which could result in serious injury or death.

### WARNING

The items listed below are extremely important and must never be neglected.

A problem, which may not be noticed at normal operating speeds, may be greatly exaggerated at high speeds.

Check the items listed below before any high speed operation.

Failure to follow the advice above may lead to loss of motorcycle control which could result in serious injury or death.

#### General

Make sure that the motorcycle has been maintained according to the scheduled maintenance chart.

#### Brakes

Check that the front and rear brakes are functioning correctly.

#### Coolant

Check that the coolant level is at the upper level line in the expansion tank. Always check the level with the engine cold.

# HOW TO RIDE THE MOTORCYCLE

## Electrical Equipment

Make sure that all electrical equipment such as the headlight, rear/brake light, turn signals and horn all work correctly.

## Engine Oil

Check that the engine oil level is correct. Make sure that the correct grade and type of oil is used when topping off.

## Drive Chain

Make sure that the drive chain is correctly adjusted and lubricated. Inspect the chain for wear and damage.

## Fuel

### **NOTICE**

In many countries, the exhaust system for this model is equipped with a catalytic converter to help reduce exhaust emission levels.

Use of leaded fuel will damage the catalytic converter. In addition, the catalytic converter can be permanently damaged if the motorcycle is allowed to run out of fuel or if the fuel level is allowed to get very low.

Always make sure you have adequate fuel for your trip.

Have sufficient fuel for the increased fuel consumption that will result from high speed operation.

## Luggage

Make sure that any luggage containers are closed, locked and securely installed on the motorcycle.

## Miscellaneous

Visually check that all fasteners are tight.

## Steering

Check that the handlebar turns smoothly without excessive free play or tight spots. Make sure that the control cables do not restrict the steering in any way.

## Tires

High speed operation is hard on tires, and tires that are in good condition are crucial to riding safely. Examine their overall condition, inflate to the correct pressure (when the tires are cold), and check the wheel balance. Securely install the valve caps after checking tire pressures. Observe the information given in the maintenance and specification sections on tire checking and tire safety.

The addition of accessories and carrying of additional weight can affect the motorcycle's handling characteristics causing changes in stability and necessitating a reduction in speed. The following information has been prepared as a guide to the potential hazards of adding accessories to a motorcycle and carrying passengers and additional loads.

## Accessories

### **WARNING**

Do not install accessories or carry luggage that impairs the control of the motorcycle.

Make sure that you have not adversely affected any lighting component, road clearance, banking capability (i.e. lean angle), control operation, wheel travel, front fork movement, visibility in any direction, or any other aspect of the motorcycle's operation.

Failure to follow the advice above may lead to loss of motorcycle control which could result in serious injury or death.

### **WARNING**

Owners should be aware that the only approved parts, accessories and conversions for any Triumph motorcycle are those which carry official Triumph approval.

We recommend accessories and conversions be completed by a competent person with the specialist knowledge and technical understanding of motorcycles, such as an authorized Triumph dealer.

In particular, it is extremely hazardous to install or replace parts or accessories whose installation requires the dismantling of, or addition to, either the electrical or fuel systems and any such modification could cause a safety hazard.

The installation of any non-approved parts, accessories or conversions may affect the handling, stability or other aspect of the motorcycle operation leading to loss of motorcycle control which could result in serious injury or death.

Triumph does not accept any liability whatsoever for defects caused by the installation of non-approved parts, accessories or conversions.

Triumph does not accept any liability whatsoever for defects caused by the incorrect installation of approved parts, accessories or conversions.

## ACCESSORIES, LOADING AND PASSENGERS

### WARNING

Install only genuine Triumph accessories to the correct Triumph motorcycle model.

Always check the Triumph Installation Instruction associated with the genuine Triumph accessory. Make sure the Triumph motorcycle model that the Triumph accessory is to be installed on, is listed as approved for the genuine Triumph accessory. For all Triumph Installation Instructions, see [www.triumphinstructions.com](http://www.triumphinstructions.com).

Never install genuine Triumph accessories to a Triumph motorcycle model that is not listed in the associated Triumph Fitting Instruction, as this may affect handling, stability or other aspects of the motorcycle operation that may lead to loss of motorcycle control which could result in serious injury or death.

### WARNING

Never ride an accessory equipped motorcycle, or a motorcycle carrying a payload of any kind, at speeds above 80 mph (130 km/h). In either/both of these conditions, speeds in excess of 80 mph (130 km/h) should not be attempted even where the legal speed limit permits this.

The presence of accessories and/or payload will cause changes in the stability and handling of the motorcycle.

Failure to allow for changes in motorcycle stability may lead to loss of motorcycle control. When riding at high speed, always be aware that various motorcycle configuration and environmental factors can adversely affect the stability of your motorcycle. For example:

- Incorrectly balanced loads on both sides of the motorcycle
- Incorrectly adjusted front and rear suspension settings
- Incorrectly adjusted tire pressures
- Excessively or unevenly worn tires
- Side winds and turbulence from other vehicles
- Loose clothing.

Remember that the 80 mph (130 km/h) absolute limit will be reduced by the installation of non-approved accessories, incorrect loading, worn tires, overall motorcycle condition and poor road or weather conditions.

Failure to follow the advice above may lead to loss of motorcycle control which could result in serious injury or death.

## Loading

**⚠ WARNING**

Always make sure that any loads carried are evenly distributed on both sides of the motorcycle. Make sure that the load is correctly secured so that it will not move around while the motorcycle is in motion.

Evenly distribute the load within each pannier (if equipped). Pack heavy items at the bottom and on the inboard side of the pannier.

Always check the load security regularly (though not while the motorcycle is in motion) and make sure that the load does not extend beyond the rear of the motorcycle.

Never exceed the maximum vehicle loading weight as specified in the Specifications section.

This maximum loading weight is made up from the combined weight of the rider, passenger, any accessories installed and any load carried.

For models that have adjustable suspension settings, make sure that front and rear spring preload and damping settings are suitable for the loading condition of the motorcycle. Note the maximum permissible payload for the panniers is stated on a label inside the pannier.

Failure to follow the advice above may lead to loss of motorcycle control which could result in serious injury or death.

**⚠ WARNING**

Never attempt to store any items between the frame and the fuel tank. This may restrict the steering aspect of the motorcycle.

Weight attached to the handlebar or front fork will increase the mass of the steering assembly. This may affect the handling, stability or other aspect of the motorcycle operation.

Failure to follow the advice above may lead to loss of motorcycle control which could result in serious injury or death.

**⚠ WARNING**

The maximum safe load for each pannier is stated on a label inside the pannier.

Never exceed this loading limit as this may cause the motorcycle to become unstable.

Failure to follow the advice above may lead to loss of motorcycle control which could result in serious injury or death.

## ACCESSORIES, LOADING AND PASSENGERS

### WARNING

If the passenger seat is used to carry small objects, they must not exceed 11 lb (5 kg) in weight, must not impair control of the motorcycle, must be securely attached and must not extend beyond the rear or sides of the motorcycle.

Even if small objects are correctly loaded onto the passenger seat, the maximum speed of the motorcycle must be reduced to 80 mph (130 km/h).

Carrying objects in excess of 11 lb (5 kg) in weight, that are insecure, impair control or extend beyond the rear or sides of the motorcycle may lead to loss of motorcycle control which could result in serious injury or death..

### Passengers

### WARNING

The handling and braking capabilities of a motorcycle will be affected by the presence of a passenger.

The rider must make allowances for these changes when operating the motorcycle with a passenger and should not attempt such operation unless trained to do so and without becoming familiar and comfortable with the changes in motorcycle operating characteristics that this brings about.

Failure to follow the advice above may lead to loss of motorcycle control which could result in serious injury or death.

### WARNING

Do not carry a passenger unless they are tall enough to reach the footrests provided.

A passenger who is not tall enough to reach the footrests will be unable to sit securely on the motorcycle and may cause instability leading to loss of motorcycle control which could result in serious injury or death.

### WARNING

Your passenger should be instructed that they can cause loss of motorcycle control by making sudden movements or by adopting an incorrect seated position.

The rider should instruct the passenger as follows:

- It is important that the passenger sits still while the motorcycle is in motion and does not interfere with the operation of the motorcycle.
- To keep their feet on the passenger footrests and to firmly hold onto either the seat strap or grab rails (if equipped) or the rider's waist or hips.
- Advise the passenger to lean with the rider when traveling around corners and not to lean unless the rider does so.

Failure to follow the advice above may lead to loss of motorcycle control which could result in serious injury or death.



## **WARNING**

Do not carry animals on your motorcycle.

An animal could make sudden and unpredictable movements that may lead to loss of motorcycle control which could result in serious injury or death.

This page intentionally left blank

## Table of Contents

Scheduled Maintenance.....	142
Disposal of Used Fluids.....	144
Scheduled Maintenance Table.....	145
600 Mile (1,000 Km) or 6 Month Service.....	000
1st Annual Service.....	000
2nd Annual Service.....	000
3rd Annual Service.....	000
4th Annual Service.....	000
6,000 and 18,000 Mile (10,000 and 30,000 Km) Service.....	000
12,000 Mile (20,000 Km) Service.....	000
24,000 Mile (40,000 Km) Service.....	000
Engine Oil.....	147
Engine Oil Level Inspection.....	147
Engine Oil and Filter Change.....	148
Engine Oil Specification and Grade (10W/40 & 10W/50).....	150
Cooling System.....	150
Coolant Level Inspection.....	151
Coolant Level Adjustment.....	152
Coolant Change.....	152
Throttle Control.....	153
Throttle Inspection.....	153
Clutch.....	154
Clutch Inspection.....	154
Clutch Adjustment.....	155
Drive Chain.....	156
Drive Chain Lubrication.....	156
Drive Chain Free Movement Inspection.....	157
Drive Chain Free Movement Adjustment.....	157
Drive Chain and Sprocket Wear Inspection.....	158
Brakes.....	159
Breaking-in New Brake Discs and Pads.....	159
Brake Pad Wear Compensation.....	160
Front Brake Wear Inspection.....	160
Rear Brake Wear Inspection.....	161
Disc Brake Fluid.....	162
Front Brake Fluid Level Inspection and Adjustment.....	163
Rear Brake Fluid Level Inspection and Adjustment.....	166
Brake Light Switches.....	167

# MAINTENANCE AND ADJUSTMENT

- Mirrors..... 167
- Steering..... 169
  - Steering Inspection..... 169
  - Wheel Bearings Inspection..... 170
  - Front Fork Inspection ..... 171
- Suspension ..... 173
  - Front Suspension Settings..... 173
  - Front Suspension Spring Preload Adjustment..... 174
  - Front Suspension Spring Preload Adjustment..... 175
  - Front Suspension Rebound and Compression Damping Adjustment..... 175
  - Front Suspension Rebound and Compression Damping Adjustment..... 176
  - Rear Suspension..... 176
  - Rear Suspension Settings ..... 176
  - Rear Suspension Spring Preload Adjustment ..... 178
  - Rear Suspension Spring Preload Adjustment ..... 179
  - Rear Suspension Rebound Damping Adjustment ..... 179
  - Rear Suspension Rebound Damping Adjustment ..... 180
  - Rear Suspension Compression Damping Adjustment ..... 180
  - Rear Suspension Compression Damping Adjustment ..... 181
  - Rear Suspension Compression Damping Adjustment ..... 181
- Bank Angle Indicators ..... 182
- Tires ..... 182
  - Tire Inflation Pressures ..... 183
  - Tire Pressure Monitoring System (TPMS) (if equipped)..... 184
  - Tire Wear ..... 184
  - Minimum Recommended Tread Depth..... 185
  - Tire Replacement ..... 185
- Battery ..... 188
  - Battery Removal..... 188
  - Battery Disposal ..... 189
  - Battery Maintenance..... 189
  - Battery Discharge..... 189
  - Battery Discharge During Storage and Infrequent Use of the Motorcycle ..... 190
  - Battery Charging..... 190
  - Battery Installation..... 191
- Fuses..... 192
  - Fuse Identification..... 192

Headlights.....	193
Headlight Adjustment.....	194
Headlight Replacement.....	194
Turn Signal Lights.....	195
Brake/Tail Light.....	195
License Plate Light.....	196

# MAINTENANCE AND ADJUSTMENT

## Scheduled Maintenance

### WARNING

Triumph Motorcycles cannot accept any responsibility for damage or injury resulting from incorrect maintenance or improper adjustment.

Scheduled maintenance must be carried out by a competent person with the specialist knowledge and technical understanding of motorcycles, such as an authorized Triumph dealer.

Incorrect or neglected maintenance may lead to a dangerous riding condition, leading to loss of motorcycle control which could result in serious injury or death.

### WARNING

All maintenance is vitally important and must not be neglected. Incorrect maintenance or adjustment may cause one or more parts of the motorcycle to malfunction.

Weather, terrain and geographical location affect maintenance. The maintenance schedule should be adjusted to match the particular environment in which the motorcycle is used and the demands of the individual owner.

Special tools, knowledge and training are required in order to correctly carry out the maintenance items listed in the scheduled maintenance chart. An authorized Triumph dealer will have the necessary knowledge, equipment, and skills to maintain your Triumph motorcycle correctly.

Scheduled maintenance must be carried out by a competent person with the specialist knowledge and technical understanding of motorcycles, such as an authorized Triumph dealer.

Incorrect or neglected maintenance may lead to a dangerous riding condition, leading to loss of motorcycle control which could result in serious injury or death.

To maintain the motorcycle in a safe and reliable condition, the maintenance and adjustments outlined in this section must be carried out as specified in the schedule of daily checks, and also in line with the scheduled maintenance chart. The information that follows describes the procedures to follow when carrying out the daily checks and some simple maintenance and adjustment items.

Scheduled maintenance may be carried out in three ways; annual maintenance, mileage based maintenance or a combination of both, depending on the mileage the motorcycle travels each year.

- ▼ Motorcycles traveling less than 6,000 miles (10,000 km) per year must be maintained annually. In addition to this, mileage based items require maintenance at their specified intervals, as the motorcycle reaches this mileage.
- ▼ Motorcycles traveling approximately 6,000 miles (10,000 km) per year must have the annual maintenance and the specified mileage based items carried out together.
- ▼ Motorcycles traveling more than 6,000 miles (10,000 km) per year must have the mileage based items maintained as the motorcycle reaches the specified mileage. In addition to this, annual based items will require maintenance at their specified annual intervals.

In all cases maintenance must be carried out at or before the specified maintenance intervals shown. For advice on which maintenance schedule is most suitable for your motorcycle, contact a competent person with the specialist knowledge and technical understanding of motorcycles, such as an authorized Triumph dealer.

Triumph Motorcycles cannot accept any responsibility for damage or injury resulting from incorrect maintenance or improper adjustment.

## Service Symbol/General Warning Symbol



The service symbol will illuminate for five seconds after the motorcycle start up sequence as a reminder that a service is due in approximately 60 miles (100 km). The service symbol will illuminate permanently when the mileage is reached, it will remain permanently illuminated until the service interval is reset. We recommend the service interval is reset by a competent person with the specialist knowledge and technical understanding of motorcycles, such as an authorized Triumph dealer.



The general warning symbol will flash if an ABS or engine management fault has occurred and the ABS and/or MIL warning lights are illuminated. The fault must be checked and rectified by a competent person with the specialist knowledge and technical understanding of motorcycles, such as an authorized Triumph dealer.

### NOTICE

Items marked \* in the Scheduled Maintenance Table are subject to additional labor charge, above the cost and time allowance for the basic service, which includes time to check only.

## MAINTENANCE AND ADJUSTMENT

### Disposal of Used Fluids

To protect the environment, do not pour the following on the ground, down sewers, drains or into groundwater sources:

- ▼ Engine oil
- ▼ Coolant
- ▼ Fuel
- ▼ Clutch and brake fluid
- ▼ Front fork oil.

Do not place used oil filters in with the general waste.

If in doubt for the disposal of the above, contact your local authority.





# MAINTENANCE AND ADJUSTMENT

Operation description	Odometer Reading in Miles (km) or Time Period, whichever comes first					
		First Service	Annual Service	Mileage Based Service		
	Daily	600 Mile (1,000 Km) or 6 Month Service	Year	6,000 and 18,000 Mile (10,000 and 30,000 Km) Service	12,000 Mile (20,000 Km) Service	24,000 Mile (40,000 Km) Service
Front and rear suspension - check for damage/leaks/smooth operation	*	*	*	*	*	*
Steering head bearings - check/adjust - except first service			*	*	*	*
Steering head bearings - lubricate					*	*
Rear suspension unit and linkage - lubricate (single rear suspension unit models only)					*	*
Fork oil - replace						*
<b>Brakes</b>						
Brake system - check operation	*					
Brake pads - check wear levels*	*	*	*	*	*	*
Brake fluid levels - check	*	*	*	*	*	*
Brake master cylinders - check for fluid leaks		*	*	*	*	*
Brake calipers - check for fluid leaks and seized pistons*		*	*	*	*	*
Brake fluid - replace - every 2 years, regardless of mileage*	Every two years, regardless of mileage					
<b>Final Drive</b>						
Drive chain slack - check/adjust	*	*	*	*	*	*
Drive chain - wear check*		*	*	*	*	*
Drive chain - lubricate		*	*	*	*	*
Drive chain rubbing strip - check for wear, cracks or damage*		*	*	*	*	*
<b>Electrical</b>						
Lights, instruments and electrical systems - check/adjust	*	*	*	*	*	*
<b>General</b>						
Bank angle indicators - check for wear*	*	*	*	*	*	*
Center and/or side stand - check for wear/smooth operation	*	*	*	*	*	*
Instruments and engine ECM - check for latest calibration download using the Triumph diagnostic tool		*	*	*	*	*
Fasteners - inspect visually for security		*	*	*	*	*
Side stand pivot pin - clean/grease		*	*	*	*	*
Carry out all outstanding Service Bulletin and warranty work		*	*	*	*	*
Carry out road test		*	*	*	*	*
Complete the service record book and reset the service indicator (if equipped)		*	*	*	*	*

## Engine Oil



In order for the engine, transmission, and clutch to function correctly, maintain the engine oil at the correct level, and change the engine oil and oil filter in accordance with scheduled maintenance requirements.

### Engine Oil Level Inspection

#### **⚠ DANGER**

Never start the engine or run the engine in a confined area.

Always operate the motorcycle in the open air or in an area with adequate ventilation.

Exhaust fumes are poisonous and will cause loss of consciousness and death within a short period of time.

#### **⚠ CAUTION**

If the engine has recently been running, the exhaust components may be hot to the touch.

To avoid skin damage, always allow the hot parts to cool before touching the exhaust system.

Contact with the hot components may cause minor or moderate injury to exposed skin.

### **NOTICE**

If the engine oil pressure is too low, the low oil pressure warning light will illuminate.

If the low oil pressure indicator remains on, stop the engine immediately and investigate the situation.

Running the engine with low oil pressure will cause severe engine damage.

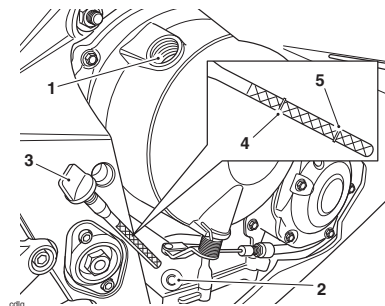

1. Filler
2. Dipstick location in crankcase
3. Dipstick
4. Upper marking
5. Lower marking

## MAINTENANCE AND ADJUSTMENT

To inspect the engine oil level:

- ▼ Start the engine and run at idle for approximately five minutes.
- ▼ Stop the engine, then wait for at least three minutes for the oil to settle.

### NOTICE

An accurate indication of the level of engine oil in the engine is only shown when the engine is at normal operating temperature and the motorcycle is upright (not on the side stand).

- ▼ Remove the dipstick.
- ▼ The oil level is indicated by lines on the dipstick. When full, the indicated oil level must be level with the upper marking on the dipstick.
- ▼ If the oil level is below the lower marking, remove the filler plug and add oil a little at a time through the filler plug hole in the clutch cover until the correct level is reached.
- ▼ Once the correct level is reached, install and tighten the filler plug.

### Engine Oil and Filter Change

#### WARNING

Prolonged or repeated contact with engine oil can lead to skin dryness, irritation and dermatitis.

Always wear suitable protective clothing and avoid skin contact with used engine oil.

Used engine oil contains harmful contamination that can lead to skin cancer.

#### CAUTION

The engine oil may be hot.

Avoid contact with the hot engine oil by wearing suitable protective clothing, gloves and eye protection.

Contact with the hot engine oil may cause minor or moderate injury to exposed skin.

#### CAUTION

If the engine has recently been running, the exhaust components may be hot to the touch.

To avoid skin damage, always allow the hot parts to cool before touching the exhaust system.

Contact with the hot components may cause minor or moderate injury to exposed skin.

The engine oil and engine oil filter must be replaced in accordance with scheduled maintenance requirements.

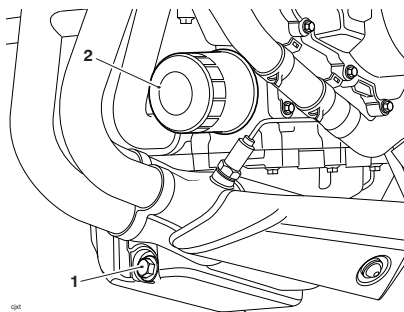

1. Oil drain plug
2. Oil filter

To change the engine oil and engine oil filter:

- ▼ Warm up the engine thoroughly, and then stop the engine and secure the motorcycle in an upright position on level ground.
  - ▼ Place an oil drain pan beneath the engine.
  - ▼ Remove the oil drain plug.
  - ▼ Discard the sealing washer.
  - ▼ Unscrew and remove the oil filter using Triumph service tool T3880313. Dispose of the old oil filter in an environmentally friendly way.
  - ▼ Apply a thin smear of clean engine oil to the sealing ring of the new oil filter.
  - ▼ Install the oil filter and tighten to 89 lbf in (10 Nm).
  - ▼ After the oil has completely drained out, install a new sealing washer to the drain plug.
  - ▼ Install and tighten the drain plug to 18 lbf ft (25 Nm).
- ▼ Fill the engine with a fully or semi synthetic 10W/40 or 10W/50 motorcycle engine oil which meets specification API SH (or higher) and JASO MA. Triumph Performance fully synthetic engine oil is recommended.
  - ▼ Start the engine and allow it to idle for a minimum of 30 seconds.

## NOTICE

Raising the engine speed above idle before the oil reaches all parts of the engine can cause engine damage or seizure.

Only raise engine speed after running the engine for 60 seconds to allow the engine oil to circulate fully.

## NOTICE

If the engine oil pressure is too low, the low oil pressure warning light will illuminate.

If the low oil pressure indicator remains on, stop the engine immediately and investigate the situation.

Running the engine with low oil pressure will cause severe engine damage.

- ▼ Make sure that the low oil pressure warning light remains off and the oil pressure message is not shown in the instrument display screen.
- ▼ Stop the engine and recheck the oil level. Adjust if necessary.

# MAINTENANCE AND ADJUSTMENT

## Engine Oil Specification and Grade (10W/40 & 10W/50)

Triumph's high performance fuel injected engines are designed to use 10W/40 or 10W/50 semi or fully synthetic motorcycle engine oil that meets specification API SH (or higher) and JASO MA, such as Castrol Power 1 Racing 4T 10W-40 (fully synthetic) engine oil, sold as Castrol Power RS Racing 4T 10W-40 (fully synthetic) in some countries.

Refer to the chart below for the correct oil viscosity (10W/40 or 10W/50) to be used in your riding area.

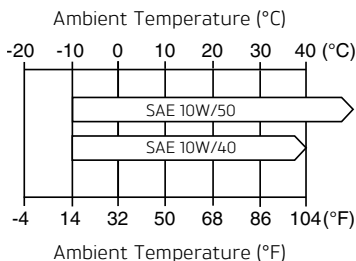

### Oil Viscosity Temperature Range

Do not add any chemical additives to the engine oil. The engine oil also lubricates the clutch and any additives could cause the clutch to slip.

Do not use mineral, vegetable, non-detergent oil, castor based oils or any oil not conforming to the required specification. The use of these oils may cause instant, severe engine damage.

Make sure that no foreign matter enters the crankcase during an engine oil change or top off.

## Cooling System



To ensure efficient engine cooling, check the coolant level each day before riding the motorcycle, and top off the coolant if the level is low.

### NOTICE

A year round, Hybrid Organic Acid Technology (known as Hybrid OAT or HOAT) coolant is installed in the cooling system when the motorcycle leaves the factory. It is colored green, contains a 50% solution of ethylene glycol based antifreeze, and has a freezing point of -31°F (-35°C).

## Corrosion Inhibitors

### **⚠ WARNING**

HD4X Hybrid OAT coolant contains corrosion inhibitors and antifreeze suitable for aluminum engines and radiators. Always use the coolant in accordance with the instructions of the manufacturer.

Coolant contains toxic chemicals that are harmful to the human body.

Contact with skin or eyes may cause severe irritation. Wear protective gloves, clothing and eye protection when handling coolant.

If coolant is inhaled, remove the person to fresh air and keep comfortable for breathing. In case of doubt or persistent symptoms, seek medical attention.

If coolant gets on your skin, flush with water immediately. Remove contaminated clothing.

If coolant gets in your eyes, flush with water for at least 15 minutes and **SEEK MEDICAL ATTENTION IMMEDIATELY**.

If coolant is swallowed, rinse the mouth with water and **SEEK MEDICAL ATTENTION IMMEDIATELY**.

**KEEP COOLANT OUT OF THE REACH OF CHILDREN.**

### **NOTICE**

HD4X Hybrid OAT coolant, as supplied by Triumph, is premixed and does not need to be diluted prior to filling or topping off the cooling system.

To protect the cooling system from corrosion, the use of corrosion inhibitor chemicals in the coolant is essential.

If coolant containing a corrosion inhibitor is not used, the cooling system will accumulate rust and scale in the water jacket and radiator. This will block the coolant passages, and considerably reduce the efficiency of the cooling system.

## Coolant Level Inspection

### **NOTICE**

The coolant level should be checked when the engine is cold (at room or ambient temperature).

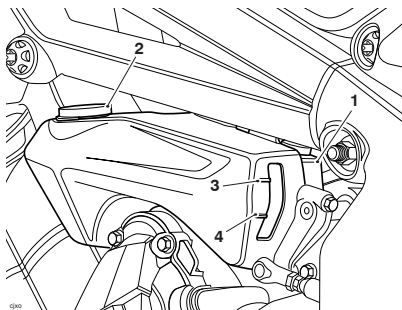

1. Expansion tank
2. Filler cap
3. MAX mark
4. MIN mark

To inspect the coolant level:

- ▼ Position the motorcycle on level ground and in an upright position. The expansion tank can be viewed from the left hand side of the motorcycle, below and towards the front of the fuel tank.
- ▼ Check the coolant level in the expansion tank. The coolant level must be between the MAX and MIN marks.

# MAINTENANCE AND ADJUSTMENT

- ▼ If the coolant is below the minimum level, the coolant level must be adjusted.

## Coolant Level Adjustment

### **CAUTION**

Do not remove the radiator pressure cap when the engine is hot.

When the engine is hot, the coolant inside the radiator will be hot and also under pressure.

Contact with this hot, pressurized coolant may cause minor or moderate injury to exposed skin.

### **NOTICE**

If hard water is used in the cooling system, it will cause scale accumulation in the engine and radiator and considerably reduce the efficiency of the cooling system.

Reduced cooling system efficiency may cause the engine to overheat and suffer severe damage.

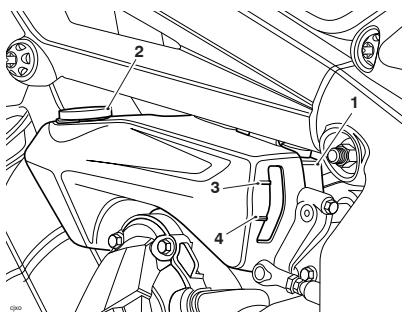

1. Expansion tank
2. Filler cap
3. MAX mark
4. MIN mark

To adjust the coolant level:

- ▼ Allow the engine to cool.
- ▼ The expansion tank cap can be removed from the left hand side of the motorcycle.
- ▼ Remove the cap from the expansion tank and add coolant mixture through the filler opening until the level reaches the MAX mark. Reinstall the cap.

### **NOTICE**

If the coolant level is being checked because the coolant has overheated, also check the level in the radiator and top off if necessary.

In an emergency, distilled water can be added to the cooling system. However, the coolant must then be drained and replenished with HD4X Hybrid OAT coolant as soon as possible.

## Coolant Change

We recommend that the coolant is changed in accordance with scheduled maintenance requirements.



## Radiator and Hoses

### CAUTION

The fan operates automatically when the engine is running.

Always keep hands and clothing away from the fan.

Contact with the rotating fan could result in minor or moderate injury.

### NOTICE

Using high pressure water sprays, such as from a car wash facility or household pressure washer, can damage the radiator fins, cause leaks and impair the radiator's efficiency.

Do not obstruct or deflect airflow through the radiator by installing unauthorized accessories, either in front of the radiator or behind the cooling fan.

Interference with the radiator airflow can cause overheating, potentially resulting in engine damage.

Check the radiator hoses for cracks or deterioration, and tension clips for tightness in accordance with scheduled maintenance requirements. Any defective items must be replaced by a competent person with the specialist knowledge and technical understanding of motorcycles, such as an authorized Triumph dealer.

Check the radiator grille and fins for obstructions by insects, leaves or mud. Clean off any obstructions with a stream of low pressure water.

## Throttle Control

### WARNING

Always be alert for changes in the 'feel' of the throttle control. Changes can be due to wear in the mechanism, which could lead to a sticking or stuck throttle control.

If any changes are detected, the throttle system must be inspected by a competent person with the specialist knowledge and technical understanding of motorcycles, such as an authorized Triumph dealer.

A sticking or stuck throttle control may lead to loss of motorcycle control which could result in serious injury or death.

## Throttle Inspection

### WARNING

Use of the motorcycle with a sticking or damaged throttle control will interfere with the throttle function. The throttle may be difficult to control and performance will be affected.

To avoid continued use of a sticking or damaged throttle control, the throttle system must be inspected by a competent person with the specialist knowledge and technical understanding of motorcycles, such as an authorized Triumph dealer.

Failure to follow the advice above may lead to loss of motorcycle control which could result in serious injury or death.

## MAINTENANCE AND ADJUSTMENT

- ▼ Check that the throttle opens smoothly, without undue force and that it closes quickly under its own return spring force without sticking and without manual intervention.
- ▼ Check that there is 0.04 - 0.08 in (1 - 2 mm) of throttle grip free play when lightly turning the throttle grip back and forth.
- ▼ If a problem is detected or any doubt exists, or if there is an incorrect amount of free play, the throttle system must be inspected by a competent person with the specialist knowledge and technical understanding of motorcycles, such as an authorized Triumph dealer.

### Clutch

The motorcycle is equipped with a cable-operated clutch.

If the clutch lever has excessive free play, the clutch may not disengage fully. This will cause difficulty in shifting gear and selecting neutral. This may cause the engine to stall and make the motorcycle difficult to control.

Conversely, if the clutch lever has insufficient free play the clutch may not engage fully, causing the clutch to slip, which will reduce performance and cause premature clutch wear.

Clutch lever free play must be checked in accordance with scheduled maintenance requirements.

### Clutch Inspection

- ▼ Check that there is 0.08 - 0.12 in clutch lever free play at the lever.
- ▼ If there is an incorrect amount of free play, adjustments must be made.

## Clutch Adjustment

To adjust the clutch:

- ▼ Turn the adjuster sleeve until the correct amount of clutch lever free play is achieved.

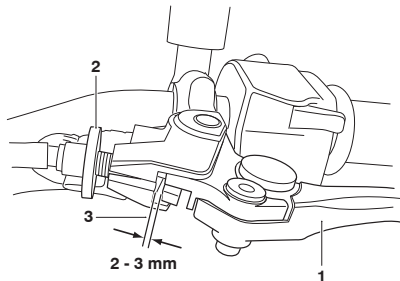

1. Clutch lever
  2. Adjuster sleeve (lock nut fully loosened)
  3. Correct clearance 0.08 - 0.12 in (2 - 3 mm)
- ▼ Check that there is 0.08 - 0.12 in (2 - 3 mm) clutch lever free play at the lever.
  - ▼ If there is an incorrect amount of free play, adjustments must be made.

- ▼ If correct adjustment cannot be made using the lever adjuster, use the cable adjuster at the lower end of the cable.

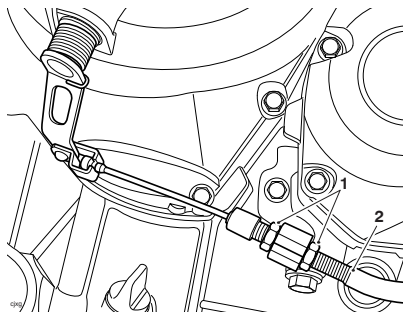

1. Adjuster locknuts
  2. Clutch outer cable
- ▼ Loosen the adjuster lock nut.
  - ▼ Turn the outer cable adjuster to give 0.08 - 0.12 in (2 - 3 mm) of free play at the clutch lever.
  - ▼ Tighten the locknut to 30.1 lbf in (3.5 Nm).

# MAINTENANCE AND ADJUSTMENT

## Drive Chain



### **! DANGER**

A loose or worn chain, or a chain that breaks or jumps off the sprockets could catch on the engine sprocket or lock the rear wheel.

A chain that snags on the engine sprocket or locking of the rear wheel will injure the rider.

Failure to follow the advice above will lead to loss of motorcycle control which will result in serious injury or death.

For safety and to prevent excessive wear the drive chain must be checked, adjusted and lubricated in accordance with scheduled maintenance requirements. Checking, adjustment and lubrication must be carried out more frequently for extreme conditions such as high speed riding, salty or heavily gritted roads.

If the chain is badly worn or incorrectly adjusted (either too loose or too tight) the chain could jump off the sprockets or break. Therefore, we recommend to always replace worn or damaged chains using genuine Triumph parts.

## Drive Chain Lubrication

Lubrication is necessary every 200 miles (300 km) and also after riding in wet weather, on wet roads, or any time that the chain appears dry.

- ▼ Use the special drive chain lubricant as recommended in the Specifications section.
- ▼ Apply lubricant to the sides of the rollers then allow the motorcycle to stand unused for at least eight hours (overnight is ideal). This will allow the lubricant to penetrate to the drive chain O-rings etc.
- ▼ Before riding, wipe off any excess lubricant.
- ▼ If the drive chain is especially dirty, clean first and then apply lubricant as mentioned above.

### **NOTICE**

Do not use a pressure washer to clean the drive chain as this may cause damage to the drive chain components.

## Drive Chain Free Movement Inspection

### **⚠ WARNING**

Make sure the motorcycle is stabilized and adequately supported.

A correctly supported motorcycle will help prevent it from falling.

An unstable motorcycle may fall, causing injury to the operator or damage to the motorcycle.

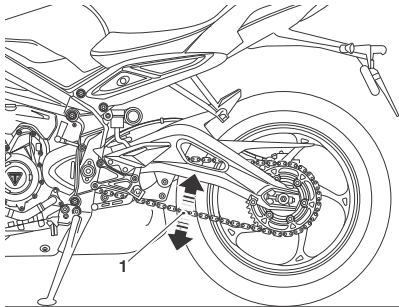

### 1. Maximum movement position

To inspect the drive chain free movement:

- ▼ Place the motorcycle on a level surface and hold it in an upright position with no weight on it.
- ▼ Rotate the rear wheel by pushing the motorcycle to find the position where the chain is tightest, and measure the vertical movement of the chain midway between the sprockets.
- ▼ The vertical movement of the drive chain must be in the range of 0.79 to 1.18 in (20 to 30 mm).

## Drive Chain Free Movement Adjustment

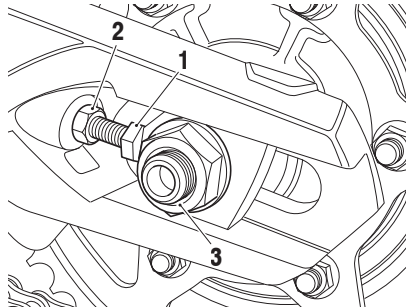

1. Adjuster bolt
2. Adjuster bolt lock nut
3. Rear wheel spindle nut

If the drive chain free movement is incorrect, adjustment must be made as follows:

- ▼ Loosen the wheel spindle nut.
- ▼ Loosen the lock nuts on both the left hand and right hand chain adjuster bolts.
- ▼ Moving both adjusters by an equal amount, turn the adjuster bolts clockwise to increase drive chain free movement and counterclockwise to reduce drive chain free movement.
- ▼ When the correct amount of drive chain free movement has been set, push the wheel into firm contact with the adjusters. Tighten both adjuster lock nuts to 15 lbf ft (20 Nm) and the rear wheel spindle nut to 81 lbf ft (110 Nm).
- ▼ Repeat the drive chain adjustment check. Readjust if necessary.

# MAINTENANCE AND ADJUSTMENT

## ⚠ WARNING

Operation of the motorcycle with insecure adjuster lock nuts or a loose wheel spindle may result in impaired stability and handling of the motorcycle.

This impaired stability and handling may lead to loss of control or an accident.

Failure to follow the advice above may lead to loss of motorcycle control which could result in serious injury or death.

- ▼ Check the rear brake effectiveness. Rectify if necessary.

## ⚠ WARNING

It is dangerous to operate the motorcycle with defective brakes.

If a problem is detected or any doubt exists, the brakes must be inspected by a competent person with the specialist knowledge and technical understanding of motorcycles, such as an authorized Triumph dealer.

Operation of the motorcycle with defective brakes may lead to loss of motorcycle control which could result in serious injury or death.

## Drive Chain and Sprocket Wear Inspection

### ⚠ WARNING

Replacement drive chains must be installed by a competent person with the specialist knowledge and technical understanding of motorcycles, such as an authorized Triumph dealer.

We recommend to always replace worn or damaged chains using genuine Triumph parts.

Incorrectly installed drive chains may result in a broken drive chain or may cause the drive chain to jump off the sprockets, leading to loss of motorcycle control which could result in serious injury or death.

### NOTICE

If the sprockets are found to be worn, always replace the sprockets and drive chain together.

Replacing worn sprockets without also replacing the drive chain will lead to premature wear of the new sprockets.

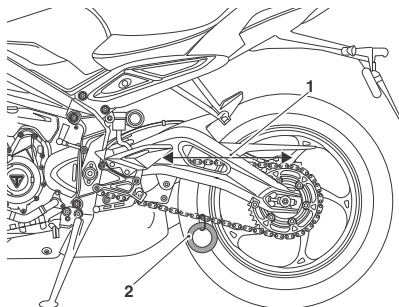

1. Measure across 20 links
2. Weight

To inspect the drive chain and sprocket wear:

- ▼ Remove the chain guard.
- ▼ Stretch the chain taut by hanging a 20 - 40 lb (10 - 20 kg) weight on the chain.
- ▼ Measure the length of 20 links on the straight part of the chain from pin center of the 1st pin to the pin center of the 21st pin. Since the chain may wear unevenly, take measurements in several places.
- ▼ If the length exceeds the maximum service limit of 12.56 in (319 mm), the chain must be replaced.
- ▼ Rotate the rear wheel and inspect the drive chain for damaged rollers, and loose pins and links.
- ▼ Also inspect the sprockets for unevenly or excessively worn or damaged teeth.

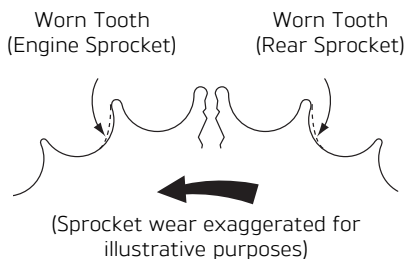

cool

- ▼ If there is any irregularity, have the drive chain and/or the sprockets replaced by an authorized Triumph dealer.
- ▼ Reinstall the chain guard, tightening the fasteners to 35 lbf in (4 Nm).

## Brakes

### Breaking-in New Brake Discs and Pads

#### **! WARNING**

Brake pads must always be replaced as a wheel set. At the front, where two calipers are installed on the same wheel, replace all the brake pads in both calipers.

After replacement brake pads have been installed, ride with extreme caution until the new pads have 'broken in'.

Replacing individual pads will reduce braking efficiency and may lead to loss of motorcycle control which could result in serious injury or death.

New brake discs and pads require a period of careful breaking-in that will optimize the performance and longevity of the discs and pads.

The recommended distance for breaking-in new pads and discs is 200 miles (300 km).

During the breaking-in period, avoid extreme braking, ride with caution and allow for greater braking distances.

## Brake Pad Wear Compensation

### **⚠ WARNING**

If the brake lever or pedal feels soft when it is applied, or if the lever/pedal travel becomes excessive, there may be air in the brake lines and hoses or the brakes may be defective.

The fault must be checked and rectified by a competent person with the specialist knowledge and technical understanding of motorcycles, such as an authorized Triumph dealer.

Riding with defective brakes may lead to a dangerous riding condition, leading to loss of motorcycle control which could result in serious injury or death.

Disc and brake pad wear is automatically compensated for and has no effect on the brake lever or pedal action. There are no parts that require adjustment on the front and rear brakes.

## Front Brake Wear Inspection

### **⚠ WARNING**

If installing new proprietary brand brake pads, check that the brake backing plate of the brake pad is the specified thickness shown in the table.

Installing brake pads with the brake backing plate less than the specified thickness may result in brake failure due to the possible loss of the brake pad as it wears.

Failure to follow the advice above may lead to loss of motorcycle control which could result in serious injury or death.

Brake pads must be inspected in accordance with scheduled requirements and replaced if worn to, or beyond the minimum service thickness.

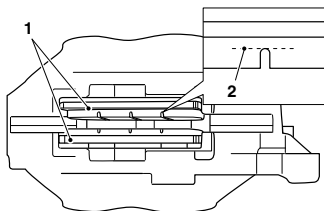

cbmz\_1

1. Carrier plate
2. Brake pad



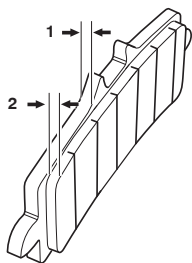

09ba\_2

1. Carrier plate
2. Brake pad lining

Brake pads for this model supplied by Triumph will have the carrier plate at the recommended thickness. Always have replacement brake pads supplied and installed by your Triumph dealer.

If the lining thickness of any brake pad is less than that specified in the table, replace all the brake pads on the wheel.

	Street Triple RS	All Other Models
Carrier Plate Minimum Thickness	0.19 in (4.8 mm)	0.16 in (4.0 mm)
Minimum Brake Pad Lining Thickness	0.04 in (1.0 mm)	0.06 in (1.5 mm)
Minimum Service Thickness (Brake Pad Lining and Carrier Plate)	0.23 in (5.8 mm)	0.22 in (5.5 mm)

## Rear Brake Wear Inspection

### WARNING

If installing new proprietary brand brake pads, check that the brake backing plate of the brake pad is the specified thickness shown in the table.

Installing brake pads with the brake backing plate less than the specified thickness may result in brake failure due to the possible loss of the brake pad as it wears.

Failure to follow the advice above may lead to loss of motorcycle control which could result in serious injury or death.

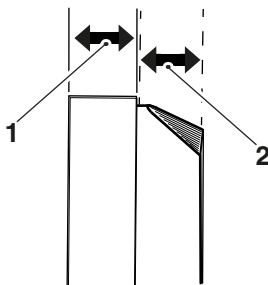

1. Carrier plate
2. Brake pad lining

Brake pads supplied by Triumph will have the carrier plate at the recommended thickness. Always have replacement brake pads supplied and installed by your Triumph dealer.

## MAINTENANCE AND ADJUSTMENT

If the lining thickness of any brake pad is less than that specified in the table, replace all the brake pads on the wheel.

	All Models
<b>Carrier Plate Minimum Thickness</b>	0.12 in (3.0 mm)
<b>Minimum Brake Pad Lining Thickness</b>	0.06 in (1.5 mm)
<b>Minimum Service Thickness (Brake Pad Lining and Carrier Plate)</b>	0.18 in (4.5 mm)

### Disc Brake Fluid

#### **WARNING**

Brake fluid is hygroscopic which means it will absorb moisture from the air.

Any absorbed moisture will greatly reduce the boiling point of the brake fluid causing a reduction in braking efficiency.

Because of this, always replace brake fluid in accordance with scheduled maintenance requirements.

Always use new brake fluid from a sealed container and never use fluid from an unsealed container or from one which has been previously opened.

Do not mix different brands or grades of brake fluid.

Check for fluid leakage around brake installed, seals and joints and also check the brake hoses for splits, deterioration and damage.

Always rectify any faults before riding.

Failure to follow the advice above may lead to loss of motorcycle control which could result in serious injury or death.

## **⚠ WARNING**

If the Anti-lock Brake System (ABS) is not functioning, the brake system will continue to function as a non-ABS equipped brake system. Reduce speed and do not continue to ride for longer than is necessary with the ABS warning light illuminated.

The fault must be checked and rectified by a competent person with the specialist knowledge and technical understanding of motorcycles, such as an authorized Triumph dealer.

Braking too hard will cause the wheels to lock, leading to loss of motorcycle control which could result in serious injury or death.

Inspect the level of brake fluid in both reservoirs and change the brake fluid in accordance with scheduled maintenance requirements. Use Triumph Performance DOT 4 brake fluid as recommended in the Specification section. The brake fluid must also be changed if it becomes, or is suspected of having become contaminated with moisture or any other contaminants.

## **NOTICE**

A special tool is required to bleed the braking system. When the brake fluid needs replacing or the hydraulic system requires maintenance, contact a competent person with the specialist knowledge and technical understanding of motorcycles, such as an authorized Triumph dealer.

## Front Brake Fluid Level Inspection and Adjustment

### All Models Except Street Triple RS

## **⚠ WARNING**

If there has been an appreciable drop in the level of the fluid in either fluid reservoir the brake system must be inspected.

If the brake lever or pedal feels soft when it is applied, or if the lever/pedal travel becomes excessive, there may be air in the brake lines or the brake may be defective.

Riding with depleted brake fluid levels, or with a brake fluid leak is dangerous and will cause reduced brake performance

Contact a competent person with the specialist knowledge and technical understanding of motorcycles, such as an authorized Triumph dealer to inspect and, if necessary, repair the brake system.

Failure to follow the advice above may lead to loss of motorcycle control which could result in serious injury or death.

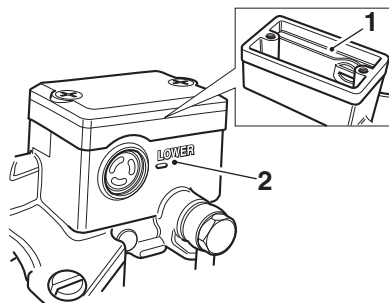

1. Front brake fluid reservoir, upper level line
2. Lower level line

## MAINTENANCE AND ADJUSTMENT

To inspect the front brake fluid level:

- ▼ Check the level of brake fluid visible in the window at the front of the reservoir unit.
- ▼ The brake fluid level must be kept between the upper and lower level lines (reservoir held horizontal).

To adjust the brake fluid level:

- ▼ Loosen the reservoir cap retaining screws and remove the reservoir cap and the diaphragm seal.
- ▼ Fill the reservoir to the upper level line using new Triumph Performance DOT 4 brake fluid from a sealed container.
- ▼ Reinstall the reservoir cap making sure that the diaphragm seal is correctly positioned between the reservoir cap and the reservoir body.
- ▼ Tighten the reservoir cap retaining screws to 9 lbf in (1 Nm).

### Street Triple RS

#### **⚠ WARNING**

If there has been an appreciable drop in the level of the fluid in either fluid reservoir the brake system must be inspected.

If the brake lever or pedal feels soft when it is applied, or if the lever/pedal travel becomes excessive, there may be air in the brake lines or the brake may be defective.

Riding with depleted brake fluid levels, or with a brake fluid leak is dangerous and will cause reduced brake performance

Contact a competent person with the specialist knowledge and technical understanding of motorcycles, such as an authorized Triumph dealer to inspect and, if necessary, repair the brake system.

Failure to follow the advice above may lead to loss of motorcycle control which could result in serious injury or death.

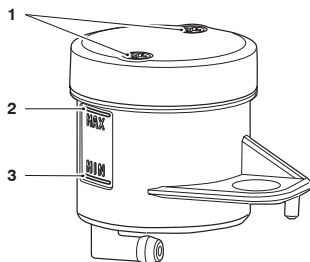

1. Reservoir cap retaining screws
2. MAX level line
3. MIN level line

To inspect the front brake fluid level:

- ▼ Check the level of brake fluid visible in the MIN and MAX section of the reservoir.
- ▼ The brake fluid level in the reservoir must be kept between the MAX and MIN level lines (reservoir held horizontal).

To adjust the brake fluid level:

- ▼ Loosen the reservoir cap retaining screws and remove the reservoir cap and the diaphragm seal.
- ▼ Fill the reservoir to the MAX level line using new Triumph Performance DOT 4 brake fluid from a sealed container.
- ▼ Install the diaphragm seal into the reservoir cap and make sure that the holes for the fasteners in the reservoir cap and the diaphragm seal are correctly aligned.

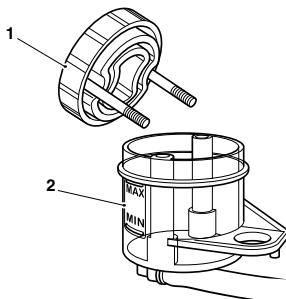

1. Reservoir cap, diaphragm seal and reservoir cap retaining screws assembly
2. Reservoir

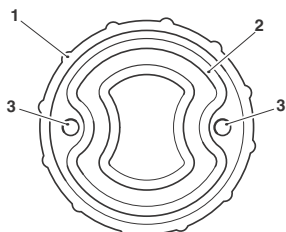

1. Reservoir cap
2. Diaphragm seal
3. Reservoir cap retaining screw holes

- ▼ Install the reservoir cap retaining screws into the reservoir cap and diaphragm seal assembly.
- ▼ Hold the assembly together and position the reservoir cap, diaphragm seal and reservoir cap retaining screws onto the reservoir.

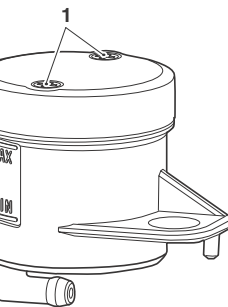

1. Reservoir cap retaining screws
- ▼ Tighten the reservoir cap retaining screws to 6 lbf in (0.7 Nm).

## WARNING

Do not over tighten reservoir cap fixings.

Over tightened reservoir cap fixings may damage the brake fluid reservoir causing a brake fluid leak leading to reduced braking efficiency.

Failure to follow the advice above may lead to loss of motorcycle control which could result in serious injury or death.

## Rear Brake Fluid Level Inspection and Adjustment

### **⚠ WARNING**

If there has been an appreciable drop in the level of the fluid in either fluid reservoir the brake system must be inspected.

If the brake lever or pedal feels soft when it is applied, or if the lever/pedal travel becomes excessive, there may be air in the brake lines or the brake may be defective.

Riding with depleted brake fluid levels, or with a brake fluid leak is dangerous and will cause reduced brake performance

Contact a competent person with the specialist knowledge and technical understanding of motorcycles, such as an authorized Triumph dealer to inspect and, if necessary, repair the brake system.

Failure to follow the advice above may lead to loss of motorcycle control which could result in serious injury or death.

The reservoir is visible from the right hand side of the motorcycle, forward of the muffler, below the rider's seat.

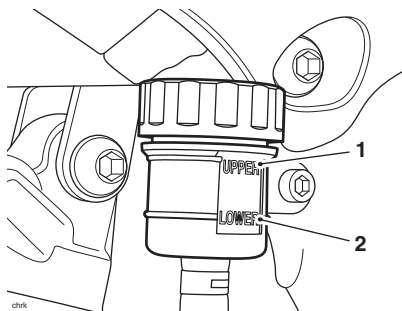

**1. Upper level line**

**2. Lower level line**

To inspect the rear brake fluid level:

- ▼ Check the level of brake fluid visible in the reservoir.
- ▼ The brake fluid level must be kept between the upper and lower level lines (reservoir held horizontal).

To adjust the rear brake fluid level:

- ▼ Loosen the reservoir cap and remove the diaphragm seal.
- ▼ Fill the reservoir to the upper level line using new Triumph Performance DOT 4 brake fluid from a sealed container.
- ▼ Re-install the reservoir cap making sure that the diaphragm seal is correctly installed.

## Brake Light Switches

### WARNING

Riding the motorcycle with defective brake lights is illegal and dangerous.

Before riding the motorcycle, make sure all lights are working.

Failure to follow the advice above could result in serious injury or death.

The brake light is activated independently by either the front or rear brake. If, with the ignition in the ON position, the brake light does not work when the front brake lever is pulled or the rear brake pedal is pressed, the fault must be checked and rectified by a competent person with the specialist knowledge and technical understanding of motorcycles, such as an authorized Triumph dealer.

## Mirrors

### WARNING

Always adjust the mirrors to provide sufficient rearward vision before riding the motorcycle.

Operation of the motorcycle with incorrectly adjusted mirrors is dangerous.

Operation of the motorcycle with incorrectly adjusted mirrors will result in loss of vision to the rear of the motorcycle. It is dangerous to ride a motorcycle without sufficient rearward vision.

Failure to follow the advice above could result in serious injury or death.

### WARNING

Never attempt to clean or adjust mirrors while riding the motorcycle. Removal of the rider's hands from the handlebars while riding the motorcycle will diminish the ability of the rider to maintain control of the motorcycle.

Only attempt to clean or adjust the mirrors while stationary.

Attempting to clean or adjust mirrors while riding the motorcycle may lead to loss of motorcycle control which could result in serious injury or death.

## Models with Bar End Mirrors

### **⚠ WARNING**

Incorrect adjustment of the bar end mirrors may cause the mirror arm to contact the fuel tank, brake or clutch levers or other parts of the motorcycle.

This will restrict brake or clutch lever operation or restrict steering movement which may affect the handling, stability or other aspect of the motorcycle operation.

Adjust the mirrors as required to make sure they do not contact any part of the motorcycle. After adjustment, move the handlebar to the left and right full lock while checking that the mirrors do not contact the fuel tank, brake or clutch levers or other parts of the motorcycle.

Failure to follow the advice above may lead to loss of motorcycle control which could result in serious injury or death.

### **NOTICE**

Incorrect adjustment of the bar end mirrors may cause the mirror arm to contact the fuel tank, brake or clutch levers or other parts of the motorcycle.

This will result in damage to the fuel tank, brake or clutch levers or other parts of the motorcycle.

Adjust the mirrors as required to make sure they do not contact any part of the motorcycle. After adjustment, move the handlebar to the left and right full lock while checking that the mirrors do not contact the fuel tank, brake or clutch levers or other parts of the motorcycle.

The bar end mirrors will be set by your authorized Triumph dealer and will not normally require any adjustment. Should adjustment be necessary, do not rotate the mirror beyond 75°, measured from the vertical section of the mirror arm.

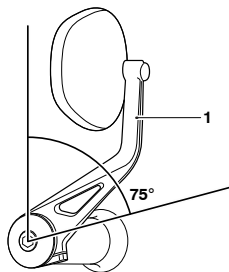

1. Mirror arm vertical section



## Steering

### **⚠ WARNING**

To prevent risk of injury from the motorcycle falling during the inspection, make sure that the motorcycle is stabilized and secured on a suitable support.

Do not exert extreme force against each wheel or rock each wheel vigorously as this may cause the motorcycle to become unstable and fall from its support.

Failure to follow the advice above could result in motorcycle damage, serious injury or death.

## Steering Inspection

### **⚠ WARNING**

Never neglect steering (steering head) bearings maintenance. Check the steering bearings in accordance with scheduled maintenance requirements and make adjustments or replace as necessary.

Scheduled maintenance must be carried out by a competent person with the specialist knowledge and technical understanding of motorcycles, such as an authorized Triumph dealer.

Riding the motorcycle with incorrectly adjusted or defective steering bearings is dangerous leading to loss of motorcycle control which could result in serious injury or death.

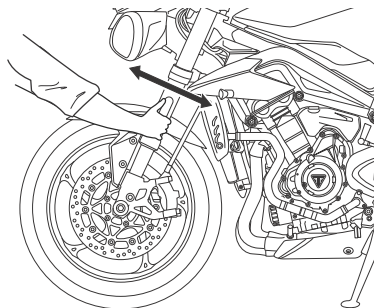

Inspecting the Steering for Free Play

To inspect the steering:

- ▼ Position the motorcycle on level ground, in an upright position.
- ▼ Raise the front wheel above the ground and support the motorcycle.

## MAINTENANCE AND ADJUSTMENT

- ▼ Standing at the front of the motorcycle, hold the lower end of the front forks outer tube and try to move them forward and backward.
- ▼ If any free play can be detected in the steering head bearings, ask your authorized Triumph dealer to inspect and rectify any faults before riding.
- ▼ Remove the support and place the motorcycle on the side stand.

### Wheel Bearings Inspection

#### **⚠ WARNING**

Never neglect wheel bearings maintenance. Check the wheel bearings in accordance with scheduled maintenance requirements and make adjustments or replace as necessary.

Scheduled maintenance must be carried out by a competent person with the specialist knowledge and technical understanding of motorcycles, such as an authorized Triumph dealer.

Riding the motorcycle with worn or damaged wheel bearings is dangerous leading to loss of motorcycle control which could result in serious injury or death.

The wheel bearings must be inspected at the intervals specified in the scheduled maintenance chart.

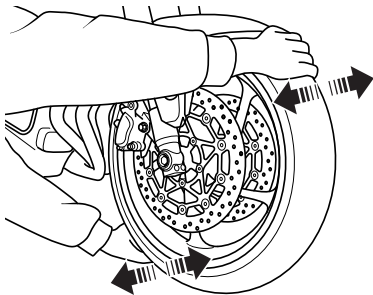

**Inspecting the Wheel Bearings**

To inspect the wheel bearings:

- ▼ Position the motorcycle on level ground, in an upright position.
- ▼ Raise the front wheel off the ground and support the motorcycle.
- ▼ Standing at the side of the motorcycle, gently rock the top of the front wheel from side to side.
- ▼ If any free play can be detected, ask your authorized Triumph dealer to inspect and rectify any faults before riding.
- ▼ Reposition the lifting device and repeat the procedure for the rear wheel.
- ▼ Remove the support and place the motorcycle on the side stand.

## NOTICE

If the wheel bearings in the front or rear wheel allow play in the wheel hub, are noisy, or if the wheel does not turn smoothly, have your authorized Triumph dealer inspect the wheel bearings.

## Front Fork Inspection

### WARNING

Never neglect front fork maintenance. Check the front forks in accordance with scheduled maintenance requirements and make adjustments or replace as necessary.

Scheduled maintenance must be carried out by a competent person with the specialist knowledge and technical understanding of motorcycles, such as an authorized Triumph dealer.

Riding with defective or damaged suspension components is dangerous and may lead to loss of motorcycle control which could result in serious injury or death.

## MAINTENANCE AND ADJUSTMENT

### **CAUTION**

All suspension units contain pressurized oil.

Do not attempt to dismantle any part of the suspension units. Inspections and repairs must be completed by a competent person with the specialist knowledge and technical understanding of motorcycles, such as an authorized Triumph dealer.

Accidental release of pressurized oil or springs could cause minor to moderate injury.

To inspect the forks:

- ▼ Position the motorcycle on level ground.
- ▼ While holding the handlebars and applying the front brake, pump the forks up and down several times.
- ▼ If roughness or excessive stiffness is detected, consult your authorized Triumph dealer.
- ▼ Examine each fork for any sign of damage, scratching of the slider surface, or for oil leaks.
- ▼ If any damage or leakage is found, consult an authorized Triumph dealer.

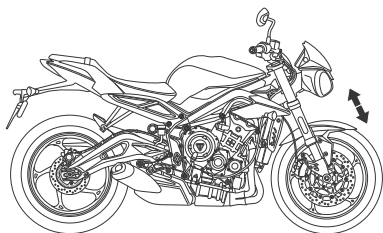

**Street Triple S (40.2 cu in (660 cc))  
shown**

## Suspension

### WARNING

Make sure that the correct balance between front and rear suspension adjustment is maintained.

If the rear suspension is adjusted the front suspension must also be adjusted.

Suspension imbalance may affect the handling and stability, leading to loss of motorcycle control which could result in serious injury or death.

### WARNING

Make sure that the adjusters are set to the same setting on both front suspension units.

Settings that vary from left to right may affect handling and stability leading to loss of motorcycle control which could result in serious injury or death.

## Front Suspension Settings

The motorcycle is delivered from the factory with all the suspension settings set at the Road (Solo Riding) setting, as shown in the relevant suspension settings tables. The Road suspension settings provide a comfortable ride and good handling characteristics for general, solo riding.

The details shown in the tables are only a guide. Setting requirements may vary for rider and passenger weight and personal preferences.

### Street Triple R - LRH

Front Suspension Settings - Street Triple R - LRH			
Loading	Spring Preload <sup>1</sup>	Rebound Damping <sup>2</sup>	Compression Damping <sup>2</sup>
Solo Riding - Track	5	1	1
Solo Riding - Sport	5	2	2
Solo Riding - Road	5	2.5	5
Solo Riding - Comfort	5	5.5	7
Rider and Passenger	5	2.5	5

<sup>1</sup> Number of adjuster turns clockwise from the fully counterclockwise position.

<sup>2</sup> Number of adjuster turns counterclockwise from the fully clockwise position.

# MAINTENANCE AND ADJUSTMENT

## Street Triple R

Front Suspension Settings - Street Triple R			
Loading	Spring Preload <sup>1</sup>	Rebound Damping <sup>2</sup>	Compression Damping <sup>2</sup>
Solo Riding - Track	5	1	1.5
Solo Riding - Sport	5	1	2
Solo Riding - Road	5	2.5	5
Solo Riding - Comfort	5	5.5	7
Rider and Passenger	5	2.5	5

<sup>1</sup> Number of adjuster turns clockwise from the fully counterclockwise position.

<sup>2</sup> Number of adjuster turns counterclockwise from the fully clockwise position.

## Street Triple RS

Front Suspension Settings - Street Triple RS			
Loading	Spring Preload <sup>1</sup>	Rebound Damping <sup>2</sup>	Compression Damping <sup>2</sup>
Solo Riding - Track	3.5	2	1
Solo Riding - Sport	3.5	2	2
Solo Riding - Road	3.5	4	5
Solo Riding - Comfort	3.5	5.5	7
Rider and Passenger	3.5	4	5

<sup>1</sup> Number of adjuster turns clockwise from the fully counterclockwise position.

<sup>2</sup> Number of adjuster turns counterclockwise from the fully clockwise position.

## Front Suspension Spring Preload Adjustment

### Street Triple R and Street Triple R - LRH

The spring preload adjuster is located at the top of each fork.

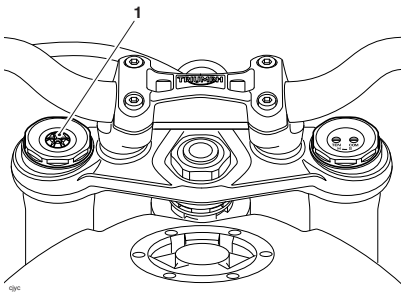

#### 1. Adjuster screw

To change the spring preload:

- ▼ Rotate the adjuster screw clockwise to increase, or counter-clockwise to decrease.
- ▼ Always count the number of clockwise turns from the fully counterclockwise position.

## Front Suspension Spring Preload Adjustment

### Street Triple RS

The spring preload adjuster is located at the bottom of both front forks.

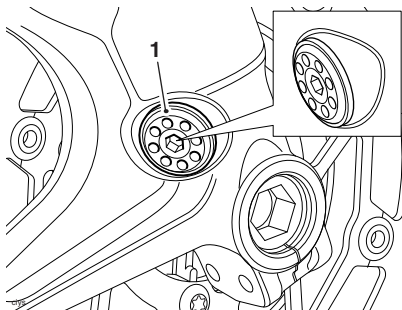

**1. Front suspension spring preload adjuster (right hand shown)**

To change the spring preload:

- ▼ Rotate the adjuster clockwise to increase, or counter-clockwise to decrease using the Allen key attached to the passenger seat.
- ▼ Always count the number of clockwise turns from the fully counterclockwise position.

## Front Suspension Rebound and Compression Damping Adjustment

### Street Triple R and Street Triple R - LRH

The rebound and compression damping adjusters are located at the top of the right hand fork.

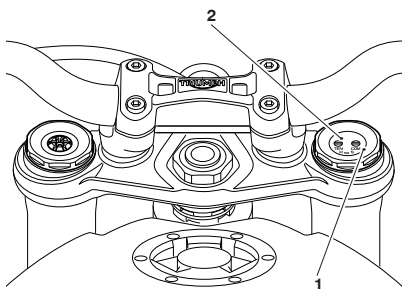

- 1. Compression damping adjuster (COM)**  
**2. Rebound damping adjuster (TEN)**

To change the rebound damping setting:

- ▼ Rotate the TEN slotted adjuster clockwise to increase, or counterclockwise to decrease.
- ▼ Always count the number of turns from the fully clockwise position.

To change the compression damping setting:

- ▼ Rotate the COM slotted adjuster clockwise to increase, or counterclockwise to decrease.
- ▼ Always count the number of turns from the fully clockwise position.

# MAINTENANCE AND ADJUSTMENT

## Front Suspension Rebound and Compression Damping Adjustment

### Street Triple RS

The rebound and compression damping adjusters are located at the top of each fork.

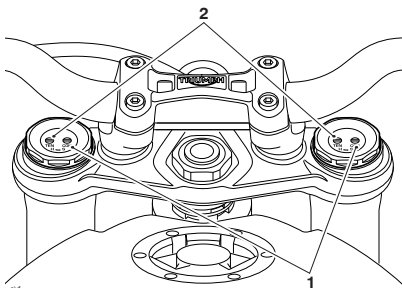

1. Compression damping adjusters
2. Rebound damping adjusters

To change the rebound damping setting:

- ▼ Rotate the TEN slotted adjuster clockwise to increase, or counterclockwise to decrease.
- ▼ Always count the number of turns from the fully clockwise position.

To change the compression damping setting:

- ▼ Rotate the COM slotted adjuster clockwise to increase, or counterclockwise to decrease.
- ▼ Always count the number of turns from the fully clockwise position.

## Rear Suspension

### **⚠ WARNING**

Make sure that the correct balance between front and rear suspension adjustment is maintained.

If the rear suspension is adjusted the front suspension must also be adjusted.

Suspension imbalance may affect the handling and stability, leading to loss of motorcycle control which could result in serious injury or death.

## Rear Suspension Settings

The motorcycle is delivered from the factory with all the suspension settings set at the Road (Solo Riding) setting as shown in the relevant suspension tables. The Road suspension settings provide a comfortable ride and good handling characteristics for general, solo riding.

The details shown in the tables are only a guide. Setting requirements may vary for rider and passenger weight and personal preferences.



## Street Triple R - LRH

Rear Suspension Settings - Street Triple R - LRH		
Loading	Spring Preload	Compression Damping <sup>1</sup>
Solo Riding - Track	Min	0.25
Solo Riding - Sport	Min	0.75
Solo Riding - Road	Min	2
Solo Riding - Comfort	Min	2.75
Rider and Passenger	Max	0.25

<sup>1</sup> Number of adjuster turns counterclockwise from the fully clockwise position.

## Street Triple R

 <b>WARNING</b>		
<p>The rear suspension unit spring preload is not rider adjustable.</p> <p>Any attempt to adjust the spring preload could result in a dangerous riding condition leading to loss of motorcycle control.</p> <p>Failure to follow the advice above may lead to loss of motorcycle control which could result in serious injury or death.</p>		
Rear Suspension Settings - Street Triple R, Street Triple Moto2™ Edition and Street Triple Moto2™ Edition		
Loading	Rebound Damping <sup>1</sup>	Compression Damping <sup>1</sup>
Solo Riding - Track	1.25	1.5
Solo Riding - Sport	1.5	2
Solo Riding - Road	2.5	2
Solo Riding - Comfort	3	2.75
Rider and Passenger	1.5	1.5

<sup>1</sup> Number of adjuster turns counterclockwise from the fully clockwise position.

# MAINTENANCE AND ADJUSTMENT

## Street Triple RS

### **⚠ WARNING**

The rear suspension unit spring preload is not rider adjustable.

Any attempt to adjust the spring preload could result in a dangerous riding condition leading to loss of motorcycle control.

Failure to follow the advice above may lead to loss of motorcycle control which could result in serious injury or death.

#### Rear Suspension Settings - Street Triple RS

Loading	Rebound Damping <sup>1</sup>	Compression Damping <sup>1</sup>
Solo Riding - Track	8	7
Solo Riding - Sport	10	10
Solo Riding - Road	14	20
Solo Riding - Comfort	20	20
Rider and Passenger	9	9

<sup>1</sup> Number of clicks counterclockwise from the fully clockwise position noting that the first stop (click) is counted as one.

## Street Triple S (40.2 cu in (660 cc))

#### Rear Suspension Settings - Street Triple S (40.2 cu in (660 cc))

Loading	Spring Preload
Solo Riding	Min
Rider and Passenger	Max

## Rear Suspension Spring Preload Adjustment

### Street Triple R - LRH

The spring preload adjuster is located at the top of the rear suspension unit.

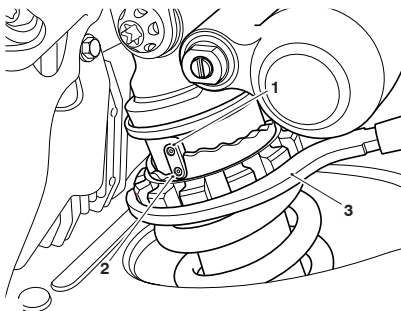

1. Peg
2. Position 1 (minimum adjustment)
3. Adjustment tool

To change the spring preload setting:

- ▼ Insert the adjustment tool supplied in the tool kit into the slot in the adjuster ring.
- ▼ Turn the adjuster ring counterclockwise to increase spring preload, and clockwise to decrease spring preload.
- ▼ Adjuster settings are counted from position one with position one being with the adjuster turned fully clockwise. Position one gives the minimum amount of spring preload.

## Rear Suspension Spring Preload Adjustment

### Street Triple S (40.2 cu in (660 cc))

The spring preload adjuster is located at the top of the rear suspension unit.

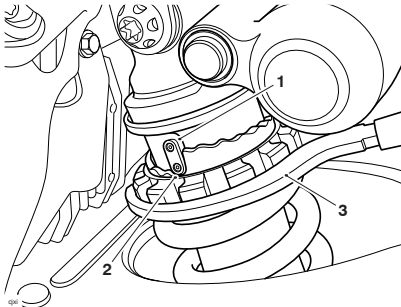

1. Peg
2. Position 1 (minimum adjustment)
3. Adjustment tool

To change the spring preload setting:

- ▼ Insert the adjustment tool supplied in the tool kit into the slot in the adjuster ring.
- ▼ Turn the adjuster ring counterclockwise to increase spring preload, and clockwise to decrease spring preload.
- ▼ When delivered from the factory, the spring preload adjuster will be set to the Solo Riding position as shown in the suggested suspension settings table.
- ▼ Adjuster settings are counted from position one with position one being with the adjuster turned fully clockwise. Position one gives the minimum amount of spring preload.

## Rear Suspension Rebound Damping Adjustment

### Street Triple R

The rebound damping adjuster is located at the bottom of the rear suspension unit on the left hand side of the motorcycle.

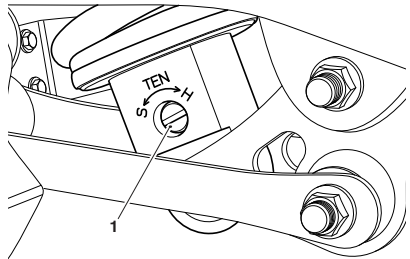

1. Slotted adjuster

To change the rebound damping setting:

- ▼ Rotate the slotted adjuster clockwise to increase rebound damping and counter-clockwise to decrease.

# MAINTENANCE AND ADJUSTMENT

## Rear Suspension Rebound Damping Adjustment

### Street Triple RS

The rebound damping adjuster is located at the bottom of the rear suspension unit on the left hand side of the motorcycle.

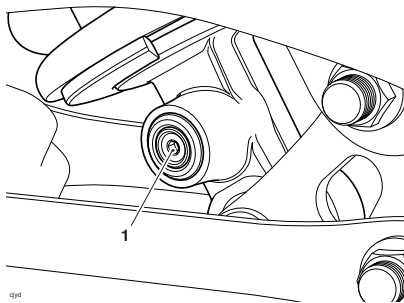

#### 1. Adjuster screw

To change the rebound damping setting:

- ▼ Rotate the adjuster screw clockwise to increase rebound damping and counter-clockwise to decrease.

## Rear Suspension Compression Damping Adjustment

### Street Triple R

The compression damping adjuster is situated adjacent to the rear suspension unit reservoir.

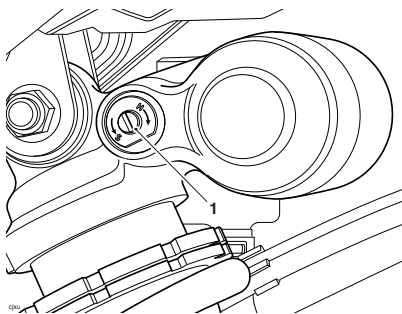

#### 1. Slotted adjuster

To adjust the compression damping setting:

- ▼ Rotate the slotted adjuster clockwise to increase, or counterclockwise to decrease.

## Rear Suspension Compression Damping Adjustment

### Street Triple R - LRH

The compression damping adjuster is situated adjacent to the rear suspension unit reservoir.

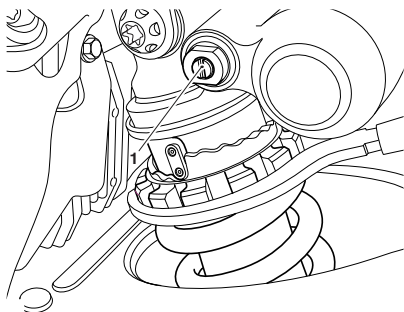

#### 1. Slotted adjuster

To change the compression damping setting:

- ▼ Rotate the slotted adjuster clockwise to increase, or counterclockwise to decrease.

## Rear Suspension Compression Damping Adjustment

### Street Triple RS

The compression damping adjuster is situated adjacent to the rear suspension unit reservoir.

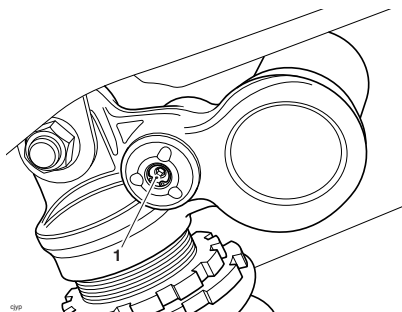

#### 1. Adjuster screw

To adjust the compression damping setting:

- ▼ Rotate the adjuster screw clockwise to increase, or counter-clockwise to decrease.

## Bank Angle Indicators

### WARNING

Always replace the bank angle indicators before they are worn to their maximum limit.

Use of a motorcycle with bank angle indicators worn beyond the maximum limit will allow the motorcycle to be banked to an unsafe angle.

Banking to an unsafe angle may lead to loss of motorcycle control which could result in serious injury or death.

Bank angle indicators are located on the rider's footrests.

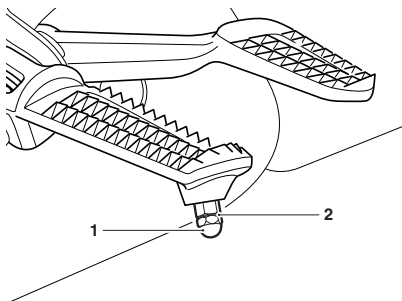

1. Bank angle indicator
2. Maximum wear limit groove

Bank angle indicators must be replaced when they have worn down to the maximum wear limit. The maximum wear limit is shown by a groove on the bank angle indicator.

Regularly check the bank angle indicators for wear.

## Tires



This model is equipped with tubeless tires, valves and wheel rims. Use only tires marked 'TUBELESS' and tubeless valves on rims marked 'SUITABLE FOR TUBELESS TYRES'.

## **⚠ WARNING**

Do not install tube type tires on tubeless rims. The bead will not seat and the tires could slip on the rims, causing rapid tire deflation.

Never install an inner tube inside a tubeless tire without the appropriate marking. This will cause friction inside the tire and the resulting heat build-up may cause the tube to burst resulting in rapid tire deflation.

Failure to follow the advice above may lead to loss of motorcycle control which could result in serious injury or death.

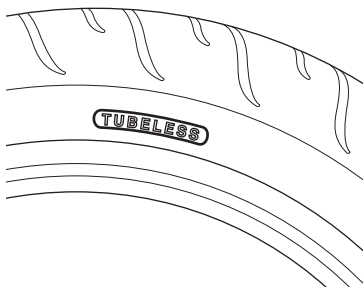

**Typical Tire Marking - Tubeless Tire**

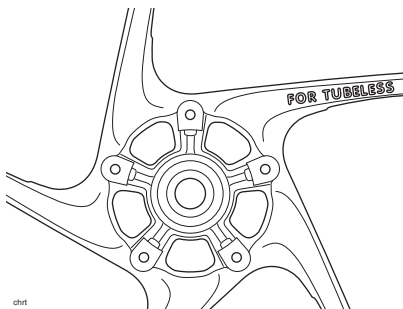

chrt

**Typical Wheel Marking - Tubeless Tire**

## Tire Inflation Pressures

### **⚠ WARNING**

Incorrect tire inflation will cause abnormal tread wear and instability problems.

Under inflation may result in the tire slipping on, or coming off the rim. Overinflation will cause instability and accelerated tread wear.

Both conditions are dangerous as they may lead to loss of motorcycle control which could result in serious injury or death.

### **⚠ WARNING**

Tire pressures which have been reduced for off-road riding will impair on-road stability.

Always make sure that the tire pressures are set as described in the Specification section for on-road use.

Operation of the motorcycle with incorrect tire pressures may lead to loss of motorcycle control which could result in serious injury or death.

Correct inflation pressure will provide maximum stability, rider comfort and tire life. Always check tire pressures before riding when the tires are cold. Check tire pressures daily and adjust if necessary. See the Specification section for details of the correct inflation pressures.

## MAINTENANCE AND ADJUSTMENT

### Tire Pressure Monitoring System (TPMS) (if equipped)

#### **NOTICE**

An adhesive label is installed to the wheel rim to indicate the position of the tire pressure sensor.

Care must be taken when replacing the tires to prevent any damage to the tire pressure sensors.

Always have the tires mounted by a competent person with the specialist knowledge and technical understanding of motorcycles, such as an authorized Triumph dealer. It is important to inform them that tire pressure sensors are installed on the wheels before they remove the tires.

#### **NOTICE**

Do not use anti puncture fluid or any other item likely to obstruct air flow to the TPMS sensor's orifices. Any blockage to the air pressure orifice of the TPMS sensor during operation will cause the sensor to become blocked, causing irreparable damage to the TPMS sensor assembly.

Damage caused by the use of anti-puncture fluid or incorrect maintenance is not considered a manufacturing defect and will not be covered under warranty.

Always have the tires mounted by a competent person with the specialist knowledge and technical understanding of motorcycles, such as an authorized Triumph dealer. It is important to inform them that tire pressure sensors are installed on the wheels before they remove the tires.

The tire pressures shown on your instruments indicate the actual tire pressure at the time of selecting the display. This may differ from the inflation pressure set when the tires are cold because tires become warmer during riding, causing the air in the tire to expand and increase the inflation pressure. The cold inflation pressures specified by Triumph take account of this.

Only adjust tire pressures when the tires are cold using an accurate pressure gage. Do not use the tire pressure display on the instruments.

### **Tire Wear**

As the tire tread wears down, the tire becomes more susceptible to punctures and failure. It is estimated that 90% of all tire problems occur during the last 10% of tread life (90% worn). It is recommended that tires are changed before they are worn to their minimum tread depth.



## Minimum Recommended Tread Depth

### WARNING

Riding with damaged or defective wheels and/or excessively worn, punctured or damaged tires will affect traction, handling and stability.

When tubeless tires become punctured, leakage is often very slow. Always inspect tires very closely for punctures. Check the tires for cuts, embedded nails or other sharp objects. Check the wheel rims for dents or deformation.

For tire replacement or for a safety inspection of the tires, contact a competent person with the specialist knowledge and technical understanding of motorcycles, such as an authorized Triumph dealer.

Riding with damaged wheels and tires is dangerous and may lead to loss of motorcycle control which could result in serious injury or death.

In accordance with the periodic maintenance chart, measure the depth of the tread with a depth gage, and replace any tire that has worn to, or beyond the minimum allowable tread depth specified in the table below:

Under 80 mph (130 km/h)	0.08 in (2 mm)
Over 80 mph (130 km/h)	Front 0.08 in (2 mm) Rear 0.12 in (3 mm)

## Tire Replacement

All Triumph motorcycles are carefully and extensively tested in a range of riding conditions to make sure that the most effective tire combinations are approved for use on each model.

It is essential that approved tires and inner tubes (if installed) mounted in approved combinations, are used when purchasing replacement items.

The use of non-approved tires and inner tubes, or approved tires and inner tubes in non-approved combinations, may lead to motorcycle instability, loss of control and an accident.

A list of approved tires and inner tubes specific to your motorcycle are available from your authorized Triumph dealer, or on the Internet at [www.triumph.co.uk](http://www.triumph.co.uk).

Tires and inner tubes must be selected in the correct combination, from the approved Tire Selector. Tires and inner tubes must be mounted and balanced according to the tire and inner tube manufacturer's instructions.

When replacement tires or inner tubes are required, contact a competent person with the specialist knowledge and technical understanding of motorcycles, such as an authorized Triumph dealer.

Initially, the new tires and inner tubes will not produce the same handling characteristics as the worn tires and inner tubes and the rider must allow adequate riding distance (approximately 100 miles (160 km)) to become accustomed to the new handling characteristics.

## MAINTENANCE AND ADJUSTMENT

The tire pressures must be checked and adjusted, and the tires and inner tubes examined for correct seating 24 hours after mounting. Rectification must be carried out as necessary. The same checks and adjustments must also be carried out when 100 miles (160 km) have been traveled after mounting.

### WARNING

Inner tubes must only be used on motorcycles equipped with spoked wheels and with tires marked 'TUBE TYPE'.

Some brands of approved tires marked 'TUBELESS' may be suitable for use with an inner tube. Where this is the case, the tire wall will be marked with text permitting the installation of an inner tube.

Use of an inner tube with a tire marked 'TUBELESS', and NOT marked as suitable for use with an inner tube, or use of an inner tube on an alloy wheel marked 'SUITABLE FOR TUBELESS TYRES' will cause deflation of the tire leading to loss of motorcycle control which could result in serious injury or death.

### WARNING

Do not install tube type tires on tubeless rims. The bead will not seat and the tires could slip on the rims, causing rapid tire deflation.

Never install an inner tube inside a tubeless tire without the appropriate marking. This will cause friction inside the tire and the resulting heat build-up may cause the tube to burst resulting in rapid tire deflation.

Failure to follow the advice above may lead to loss of motorcycle control which could result in serious injury or death.

### WARNING

If a tire or inner tube sustains a puncture, the tire and inner tube must be replaced.

Failure to replace a punctured tire and inner tube, or operation with a repaired tire or inner tube may cause instability leading to loss of motorcycle control which could result in serious injury or death.

### WARNING

If tire damage is suspected, such as after striking an object, the tire must be inspected both internally and externally by a competent person with the specialist knowledge and technical understanding of motorcycles, such as an authorized Triumph dealer.

Tire damage may not always be visible from the outside.

Operation of the motorcycle with damaged tires may lead to loss of motorcycle control which could result in serious injury or death.

## WARNING

Use of a motorcycle with incorrectly seated tires or inner tubes, incorrectly adjusted tire pressures, or when not accustomed to its handling characteristics may lead to loss of motorcycle control which could result in serious injury or death.

## WARNING

ABS operates by comparing the relative speed of the front and rear wheels.

Use of non-recommended tires can affect wheel speed and cause the ABS function not to operate in conditions where the ABS would normally function.

A list of approved tires specific to these models is available from your authorized Triumph dealer, or on the Internet at [www.triumph.co.uk](http://www.triumph.co.uk).

Failure to follow the advice above may lead to loss of motorcycle control which could result in serious injury or death.

## WARNING

Accurate wheel balance is necessary for safe, stable handling of the motorcycle. Do not remove or change any wheel balance weights. Incorrect wheel balance may cause instability.

Only use self-adhesive weights. Clip on weights may damage the wheel, tire or inner tube resulting in tire deflation.

When wheel balancing is required, such as after tire or inner tube replacement, contact a competent person with the specialist knowledge and technical understanding of motorcycles, such as an authorized Triumph dealer.

IFailure to follow the advice above may lead to loss of motorcycle control which could result in serious injury or death.

## WARNING

Tires and inner tubes that have been used on a rolling road dynamometer may become damaged. In some cases, the damage may not be visible on the external surface of the tire.

Tires and inner tubes must be replaced after such use as continued use of a damaged tire or inner tube may cause instability.

Failure to follow the advice above may lead to loss of motorcycle control which could result in serious injury or death.

# MAINTENANCE AND ADJUSTMENT

## Battery

### ⚠ WARNING

The battery contains sulfuric acid (battery acid). Contact with skin or eyes may cause severe burns. Wear protective clothing and a face shield.

If battery acid gets on your skin, flush with water immediately.

If battery acid gets in your eyes, flush with water for at least 15 minutes and SEEK MEDICAL ATTENTION IMMEDIATELY.

If battery acid is swallowed, drink large quantities of water and SEEK MEDICAL ATTENTION IMMEDIATELY.

KEEP BATTERY ACID OUT OF THE REACH OF CHILDREN.

Failure to follow the advice above could result in serious injury or death.

### ⚠ WARNING

Make sure that there is adequate ventilation when charging or using the battery in an enclosed space.

Under certain circumstances, the battery may release explosive gases. Make sure to keep all sparks, flames and cigarettes away from the battery.

Do not attach jump leads to the battery, touch the battery cables together or reverse the polarity of the cables, as any of these actions may cause a spark which would ignite battery gases causing a risk of serious injury or death.

### ⚠ WARNING

The battery contains harmful materials.

Always keep children and pets away from the battery at all times.

Failure to follow the advice above could result in serious injury or death.

## Battery Removal

### ⚠ WARNING

Make sure that the battery terminals do not touch the motorcycle frame.

This may cause a short circuit or spark which would ignite battery gases.

Failure to follow the advice above could result in serious injury or death.

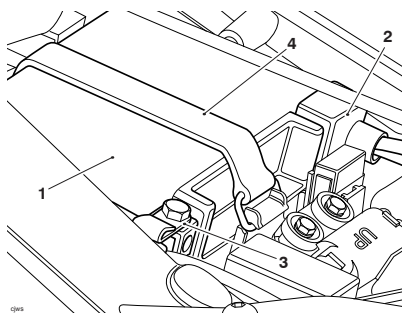

1. Battery
2. Positive (red) terminal
3. Negative (black) terminal
4. Battery strap

To remove the battery:

- ▼ Remove the passenger and rider's seats, (see page 114).
- ▼ Remove the battery strap.
- ▼ Disconnect the battery leads, negative (black) lead first and then the positive lead.
- ▼ Remove the battery from its housing.

## Battery Disposal

Should the battery ever require replacement, the original battery must be handed to a recycling agent who will make sure that the dangerous substances from which the battery is manufactured do not pollute the environment.

## Battery Maintenance

### **WARNING**

Battery acid is corrosive and poisonous and will cause damage to unprotected skin.

Never swallow battery acid or allow it to come into contact with the skin.

To prevent injury, always wear eye and skin protection when handling the battery.

The battery is a sealed type and does not require any maintenance other than checking the voltage and routine recharging when required, such as during storage.

Clean the battery using a clean, dry cloth. Make sure that the cable connections are clean.

It is not possible to adjust the battery acid level in the battery; the sealing strip must not be removed.

## Battery Discharge

### **NOTICE**

The charge level in the battery must be maintained to maximize battery life. Failure to maintain the battery charge level could cause serious internal damage to the battery.

Under normal conditions, the motorcycle charging system will keep the battery fully charged. However, if the motorcycle is unused, the battery will gradually discharge due to a normal process called self discharge; the clock, Engine Control Module (ECM) memory, high ambient temperatures, or the addition of electrical security systems or other electrical accessories will all increase this rate of battery discharge. Disconnecting the battery from the motorcycle during storage will reduce the rate of discharge.

## MAINTENANCE AND ADJUSTMENT

### Battery Discharge During Storage and Infrequent Use of the Motorcycle

During storage or infrequent use of the motorcycle, inspect the battery voltage weekly using a multimeter. Follow the manufacturer's instructions supplied with the meter.

Should the battery voltage fall below 12.7 Volts, the battery should be charged.

Allowing a battery to discharge or leaving it discharged for even a short period of time causes sulphation of the lead plates. Sulphation is a normal part of the chemical reaction inside the battery, however over time the sulphate can crystallize on the plates making recovery difficult or impossible. This permanent damage is not covered by the motorcycle warranty, as it is not due to a manufacturing defect.

Keeping the battery fully charged reduces the likelihood of it freezing in cold conditions. Allowing a battery to freeze will cause serious internal damage to the battery.

### Battery Charging

#### WARNING

The battery contains sulfuric acid (battery acid). Contact with skin or eyes may cause severe burns. Wear protective clothing and a face shield.

If battery acid gets on your skin, flush with water immediately.

If battery acid gets in your eyes, flush with water for at least 15 minutes and **SEEK MEDICAL ATTENTION IMMEDIATELY.**

If battery acid is swallowed, drink large quantities of water and **SEEK MEDICAL ATTENTION IMMEDIATELY.**

**KEEP BATTERY ACID OUT OF THE REACH OF CHILDREN.**

Failure to follow the advice above could result in serious injury or death.

#### NOTICE

Do not use an automotive quick charger as it may overcharge and damage the battery.

For help with selecting a battery charger, checking the battery voltage or battery charging, contact a competent person with the specialist knowledge and technical understanding of motorcycles, such as an authorized Triumph dealer.

Should the battery voltage fall below 12.7 Volts, the battery should be charged using a Triumph approved battery charger. Always remove the battery from the motorcycle and follow the instructions supplied with the battery charger.

For extended periods of storage (beyond two weeks) the battery should be removed from the motorcycle and kept charged using a Triumph approved maintenance charger.

Similarly, should the battery charge fall to a level where it will not start the motorcycle, remove the battery from the motorcycle before charging.

## Battery Installation

### WARNING

Make sure that the battery terminals do not touch the motorcycle frame.

This may cause a short circuit or spark which would ignite battery gases.

Failure to follow the advice above could result in serious injury or death.

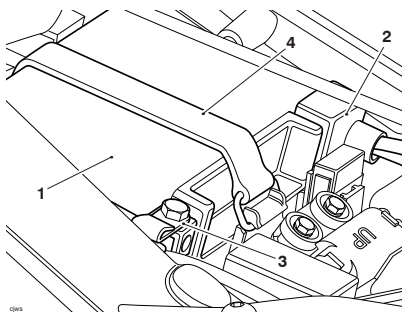

1. Battery
2. Positive (red) terminal
3. Negative (black) terminal
4. Battery strap

To install the battery:

- ▼ Position the battery into its housing.
- ▼ Reconnect the battery, positive (red) lead first and then the negative lead.
- ▼ Tighten the battery terminals to 40 lbf in (4.5 Nm).
- ▼ Apply a light coat of grease to the terminals to prevent corrosion.
- ▼ Cover the positive terminal with the protective cap.
- ▼ Reinstall the battery strap.
- ▼ Re-install the rider and passenger seat.

# MAINTENANCE AND ADJUSTMENT

## Fuses

### **WARNING**

Always replace blown fuses with new ones of the correct rating (as specified on the fuse box cover).

Never replace a blown fuse with a fuse of a different rating.

Use of an incorrect fuse could lead to an electrical problem, resulting in motorcycle damage and leading to loss of motorcycle control which could result in serious injury or death.

### **NOTICE**

A blown fuse is indicated when all of the systems protected by that fuse become inoperative. When checking for a blown fuse, use the tables to establish which fuse has blown.

The fuse boxes are located underneath the rider's seat. To allow access to the fuse boxes, the rider's seat must be removed (see page 114).

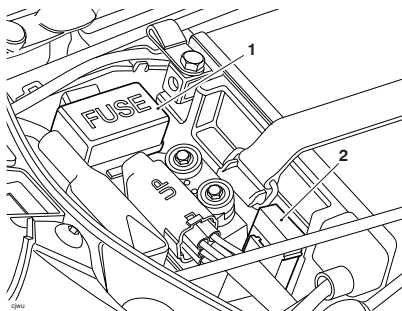

1. Fuse box
2. Main fuse (30 Amp)

## Fuse Identification

Spare fuses are located on the inside of the fuse box cover and should be replaced if used.

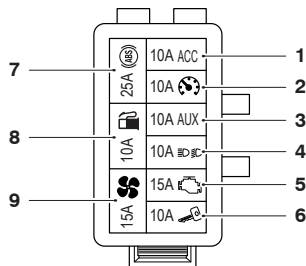

Fuse Box

Position	Circuit Protected	Rating (Amps)
1	Accessories	10
2	Instruments	10
3	Auxiliary	10
4	Lighting	10
5	Engine management system	15
6	Ignition	10
7	ABS modulator	25
8	Fuel pump	10
9	Cooling fan	15



## Headlights



### **⚠ WARNING**

Adjust road speed to suit the visibility and weather conditions in which the motorcycle is being operated.

Make sure that the headlight beam is adjusted to illuminate the road surface sufficiently far ahead without blinding oncoming traffic.

An incorrectly adjusted headlight may impair visibility for oncoming traffic leading to an accident which could result in serious injury or death.

### **⚠ WARNING**

Never attempt to adjust a headlight beam when the motorcycle is in motion.

Any attempt to adjust a headlight beam when the motorcycle is in motion may lead to loss of motorcycle control which could result in serious injury or death.

### **NOTICE**

Do not cover the headlight or lens with any item likely to obstruct air flow to, or prevent heat escaping from, the headlight lens.

Covering the headlight lens during operation with items of clothing, luggage, adhesive tape, devices intended to alter or adjust the headlight beam or non genuine headlight lens covers will cause the headlight lens to overheat and distort, causing irreparable damage to the headlight assembly.

Damage caused by overheating is not considered a manufacturing defect and will not be covered under warranty.

If the headlight must be covered during use - such as taping of the headlight lens required during closed-course conditions - the headlight must be disconnected.

# MAINTENANCE AND ADJUSTMENT

## Headlight Adjustment

The vertical beams of the left and right hand headlights can only be adjusted together. Independent adjustment is not possible.

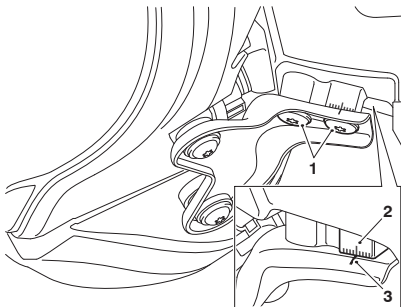

1. Headlight bracket bolts
2. Front subframe alignment marks
3. Headlight bracket mark

To vertically adjust the headlights:

- ▼ Switch the ignition on. The engine does not need to be running.
- ▼ Switch the headlight dipped beam on.
- ▼ Loosen the two headlight bracket bolts securing the headlight bracket to the front subframe sufficiently to allow restricted movement of the headlights.
- ▼ Using the headlight bracket mark and the alignment markings on the front subframe, adjust the position of the headlights to give the required beam setting. Each alignment mark on the subframe represents 1°.
- ▼ Moving the headlight bracket forwards moves the headlight upwards. Moving the headlight bracket rearwards moves the headlights downwards.
- ▼ Tighten the headlight bracket bolts to 62 lbf in (7 Nm).

- ▼ Recheck the headlight beam settings.
- ▼ Switch the headlights off when the beam settings are satisfactorily set.

## Headlight Replacement

The headlight unit is a sealed, maintenance free LED unit. The headlight unit must be replaced in the event of the failure of the headlight.

## Turn Signal Lights

### Models equipped with LEDs

The LED turn signal light units are sealed, maintenance free LED units. The turn signal assembly must be replaced in the event of the failure of the turn signal light.

### Models equipped with Bulbs

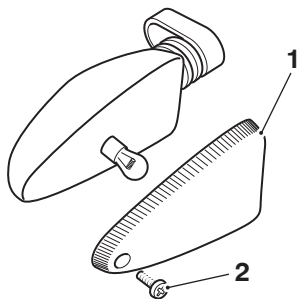

celc

1. Lens
2. Turn signal lens screw

To replace the turn signal light bulb:

- ▼ The lens on each signal light is held in place by a screw located in the body of the light.
- ▼ Loosen the signal lens screw.
- ▼ Remove the lens to gain access to the bulb for replacement.
- ▼ Replace the bulb.
- ▼ Re-install the lens making sure that the locating tang is correctly aligned to the signal body.
- ▼ Tighten the signal lens screw to 9 lbf in (1 Nm).

## Brake/Tail Light

The brake/tail light unit is a sealed, maintenance-free LED unit. The tail light unit must be replaced in the event of the failure of the tail light.

## License Plate Light

### Bulb Replacement

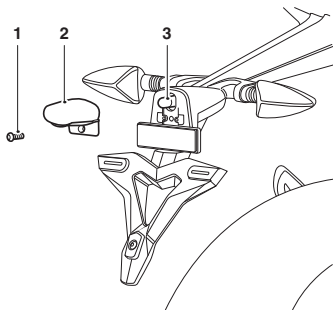

1. **Fastener**
2. **Lens**
3. **Bulb**

To replace the license plate light bulb:

- ▼ Loosen the fastener and remove the lens of the license plate light.
- ▼ Replace the bulb.
- ▼ Re-install the lens and tighten the fastener to 9 lbf in (1 Nm).

**Table of Contents**

Cleaning .....	198
Preparation for Washing.....	198
Where to be Careful.....	199
Washing.....	199
After Washing.....	200
Gloss Paintwork Care.....	200
Matt Paintwork Care .....	200
Aluminum Items - not Lacquered or Painted .....	200
Chrome and Stainless Steel Care .....	201
Black Chrome Care .....	201
Exhaust System Care.....	202
Seat Care.....	202
Windshield Care (if equipped).....	203
Leather Products Care.....	204
Storage.....	205

## CLEANING AND STORAGE

### Cleaning

Frequent, regular cleaning is an essential part of the maintenance of your motorcycle. If regularly cleaned, the appearance will be preserved for many years.

Cleaning with cold water containing an automotive cleaner is essential at all times but particularly so after exposure to sea breezes, sea water, dusty or muddy roads and in winter when roads are treated for ice and snow.

Do not use household detergent, as the use of such products will lead to premature corrosion.

Although, under the terms of your motorcycle warranty, cover is provided against the corrosion of certain items, the owner is expected to observe this reasonable advice which will safeguard against corrosion and enhance the appearance of the motorcycle.

### Preparation for Washing

Before washing, precautions must be taken to keep water off the following places.

Rear opening of the exhausts: Cover with a plastic bag secured with rubber bands.

Clutch and brake levers, switch housings on the handlebar: Cover with plastic bags.

Ignition switch and steering lock: Cover the keyhole (if applicable) with tape.

Remove any items of jewelry such as rings, watches, zips or belt buckles, which may scratch or otherwise damage painted or polished surfaces.

Use separate cleaning sponges or cleaning cloths for washing painted/polished surfaces and chassis areas. Chassis areas (such as wheels and under fenders) will be exposed to more abrasive road grime and dust, which may then scratch painted or polished surfaces, if the same sponge or cleaning cloths are used.

## Where to be Careful

### NOTICE

Do not use high pressure spray washers or steam cleaners.

Use of high pressure spray washers and steam cleaners may damage seals, and cause water and steam to be forced into bearings and other components causing premature wear from corrosion and loss of lubrication.

### NOTICE

Do not spray any water at all near the air intake duct.

The air intake duct is located under the rider's seat, under the fuel tank or near the steering head.

Any water sprayed in this area could enter the airbox and engine, causing damage to both items.

Do not get water near the following places:

- ▼ Air and any intake duct
- ▼ Any visible electrical components
- ▼ Brake cylinders and brake calipers
- ▼ Handlebar switch housings
- ▼ Steering head bearings
- ▼ Instruments
- ▼ Oil filler cap
- ▼ Rear bevel box breather (if equipped)
- ▼ Rear of headlights
- ▼ Seats
- ▼ Suspension seals and bearings
- ▼ Under the fuel tank
- ▼ Wheel bearings.

## Washing

To wash the motorcycle, do the following:

- ▼ Make sure that the motorcycle engine is cold.
- ▼ Prepare a mixture of clean, cold water and mild automotive cleaner or low alkaline soap.
- ▼ Do not use a highly alkaline soap as commonly found at commercial car washes because it will leave a residue on painted surfaces and may also cause water spotting.
- ▼ Wash the motorcycle with a sponge or soft cloth.
- ▼ Do not use abrasive scouring pads or steel wool. They will damage the finish.
- ▼ Rinse the motorcycle thoroughly with clean, cold water.

## After Washing

### WARNING

Never wax or lubricate the brake discs. Always clean the brake disc with a proprietary brand of oil-free brake disc cleaner.

Waxed or lubricated brake discs may lead to loss of motorcycle control which could result in serious injury or death.

After washing the motorcycle, do the following:

- ▼ Remove the plastic bags and tape, and clear the air intakes.
- ▼ Lubricate the pivots, bolts and nuts.
- ▼ Test the brakes before motorcycle operation.
- ▼ Use a dry cloth or chamois leather to absorb water residue. Do not allow water to stand on the motorcycle as this will lead to corrosion.
- ▼ Start the engine and run it for 5 minutes. Make sure that there is adequate ventilation for the exhaust fumes.

## Gloss Paintwork Care

Gloss paintwork should be washed and dried as described previously, then protected using a high quality automotive wax polish. Always follow the manufacturer's instructions and repeat regularly to maintain your motorcycle's appearance.

## Matt Paintwork Care

Matt paintwork requires no greater care than that already recommended for gloss paintwork.

- ▼ Do not use any polish or wax on matt paintwork.
- ▼ Do not try and polish out scratches.

## Aluminum Items - not Lacquered or Painted

Items such as brake and clutch levers, wheels, engine covers, engine cooling fins, upper and lower yokes and throttle bodies on some models must be correctly cleaned to preserve their appearance. Please contact your dealer if you are unsure which components on your motorcycle are aluminum parts not protected by paint or lacquer, and for guidance on how to clean those items.

Use a proprietary brand of aluminum cleaner which does not contain abrasive or caustic elements.

Clean aluminum items regularly, in particular after use in inclement weather, where the components must be hand washed and dried each time the machine is used.

Warranty claims due to inadequate maintenance will not be allowed.



## Chrome and Stainless Steel Care

All chrome and stainless steel parts of your motorcycle must be cleaned regularly to avoid a deterioration of its appearance.

### Washing

Wash as previously described.

### Drying

Dry the chrome and stainless steel parts as far as possible with a soft cloth or chamois leather.

### Protecting

#### **NOTICE**

The use of products containing silicone will cause discoloration of the chrome and stainless steel parts and must not be used.

The use of abrasive cleaning products will damage the finish and must not be used.

When the chrome and stainless steel is dry, apply a suitable proprietary chrome cleaner on to the surface, following the manufacturer's instructions.

It is recommended that regular protection be applied to the motorcycle as this will both protect and enhance its appearance.

## Black Chrome Care

Items such as headlight bowls and mirrors on some models must be correctly cleaned to preserve their appearance. Please contact your dealer if you are unsure which components on your motorcycle are black chrome parts. Maintain the appearance of black chrome items by rubbing a small amount of light oil into the surface.

## Exhaust System Care

All parts of the exhaust system of your motorcycle must be cleaned regularly to avoid a deterioration of its appearance. These instructions can be applied to chrome, brushed stainless steel and carbon fiber components; matt painted exhaust systems should be cleaned as above, noting the care instructions in the Matt Paintwork section previously.

The exhaust system must be cool before washing to prevent water spotting.

### Washing

Wash as previously described.

Make sure that no soap or water enters the exhausts.

### Drying

Dry the exhaust system as far as possible with a soft cloth or chamois leather. Do not run the engine to dry the system or spotting will occur.

## Protecting

### **NOTICE**

The use of products containing silicone will cause discoloration of the chrome and stainless steel parts and must not be used.

The use of abrasive cleaning products will damage the finish and must not be used.

When the exhaust system is dry, apply a suitable proprietary motorcycle protection spray onto the surface, following the manufacturer's instructions.

It is recommended that regular protection be applied to the system as this will both protect and enhance the system's appearance.

## Seat Care

### **NOTICE**

Do not use chemicals or high pressure spray washers to clean the seat.

Using chemicals or high pressure spray washers may damage the seat cover.

To help maintain its appearance, clean the seat using a sponge or cleaning cloth with soap and water.

**Windshield Care (if equipped)****! WARNING**

Never attempt to clean the windshield while riding the motorcycle.

Removal of the rider's hands from the handlebars while riding the motorcycle will diminish the ability of the rider to maintain the control of the motorcycle.

Attempting to clean the windshield while riding the motorcycle may lead to loss of motorcycle control which could result in serious injury or death.

**NOTICE**

Corrosive chemicals such as battery acid will damage the windshield. Never allow corrosive chemicals to contact the windshield.

**NOTICE**

Products such as window cleaning fluids, insect remover, rain repellent, scouring compounds, gasoline or strong solvents such as alcohol, acetone, carbon tetrachloride, etc. will damage the windshield.

Never allow these products to contact the windshield.

Clean the windshield with a solution of mild soap or detergent and clean cold water.

After cleaning, rinse well and then dry with a soft, lint-free cloth.

If the transparency of the windshield is reduced by scratches or oxidation which cannot be removed, the windshield must be replaced.

## Leather Products Care

It is recommend that the leather products are periodically cleaned with a damp cloth and allowed to dry naturally at room temperature. This will maintain the appearance of the leather and ensure the long life of the product.

The Triumph leather product is a natural product and lack of care can result in damage and permanent wear.

Follow these simple instructions to prolong the life of the leather product:

- ▼ Do not use household cleaning products, bleach, detergents containing bleach or any kind of solvent to clean the leather product.
- ▼ Do not immerse the leather product in water.
- ▼ Avoid direct heat from fires and radiators which can dry out and distort the leather.
- ▼ Do not leave the leather product in direct sunlight for prolonged periods of time.
- ▼ Do not dry the leather product by applying direct heat to it at any time.
- ▼ If the leather product does get wet, absorb any excess water with a soft clean cloth then leave the leather product to dry naturally at room temperature.
- ▼ Avoid exposure of the leather product to high levels of salt, for example sea/salt water or road surfaces that have been treated during the winter for ice and snow.
- ▼ If exposure to salt is unavoidable, clean the leather product immediately after each exposure using a damp cloth then leave the leather product to dry naturally at room temperature.
- ▼ Gently clean any minor marks with a damp cloth then leave the leather product to dry naturally at room temperature.
- ▼ Place the leather product in a fabric bag or cardboard box to protect it when in storage. Do not use a plastic bag.

## Storage

### Preparation for Storage

To prepare the motorcycle for storage, do the following:

- ▼ Clean and dry the entire vehicle thoroughly.
- ▼ Fill the fuel tank with the correct grade of unleaded fuel and add a fuel stabilizer (if available), following the fuel stabilizer manufacturer's instructions.

### WARNING

Gasoline is extremely flammable and can be explosive under certain conditions.

Turn the ignition switch off. Do not smoke.

Make sure the area is well ventilated and free from any source of flame or sparks; this includes any appliance with a pilot light.

- ▼ Remove the spark plug from each cylinder and put several drops (0.17 fl oz / 5 cc) of engine oil into each cylinder. Cover the spark plug holes with a piece of cloth or rag. With the engine stop switch in the RUN position, push the starter button for a few seconds to coat the cylinder walls with oil. Install the spark plugs, tightening to 9 lbf ft (12 Nm).
- ▼ Change the engine oil and filter (see page 148).
- ▼ Check and if necessary correct the tire pressures (see the relevant Specification section).
- ▼ Set the motorcycle on a stand so that both wheels are raised off the ground. (If this cannot be done, put boards under the front and rear wheels to keep dampness away from the tires).
- ▼ Spray rust inhibiting oil (there are numerous products on the market and your dealer will be able to offer you local advice) on all unpainted metal surfaces to prevent rusting. Prevent oil from getting on rubber parts, brake discs or in the brake calipers.
- ▼ Lubricate and if necessary adjust the drive chain (see page 156).
- ▼ Make sure the cooling system is filled with a 50% mixture of coolant (noting that HD4X Hybrid OAT coolant, as supplied by Triumph, is pre-mixed and requires no dilution) and distilled water solution (see page 150).
- ▼ Remove the battery, and store it where it will not be exposed to direct sunlight, moisture, or freezing temperatures. During storage it should be given a slow charge (one Ampere or less) about once every two weeks (see page 190).
- ▼ Store the motorcycle in a cool, dry area, away from sunlight, and with a minimum daily temperature variation.
- ▼ Put a suitable porous cover over the motorcycle to keep dust and dirt from collecting on it. Avoid using plastic or similar non-breathable, coated materials that restrict air flow and allow heat and moisture to accumulate.

## CLEANING AND STORAGE

### Preparation after Storage

To prepare the motorcycle to be ridden after storage, do the following:

- ▼ Install the battery (if removed) (see page 191).
  - ▼ If the motorcycle has been stored for more than four months, change the engine oil (see page 148).
  - ▼ Check all the points listed in the Daily Safety Checks section.
  - ▼ Before starting the engine, remove the spark plugs from each cylinder.
  - ▼ Put the side stand down.
  - ▼ Crank the engine on the starter motor several times.
  - ▼ Reinstall the spark plugs, tightening to 9 lbf ft (12 Nm), and start the engine.
- ▼ Check and if necessary correct the tire pressures (see the relevant Specification section).
  - ▼ Clean the entire vehicle thoroughly.
  - ▼ Check the brakes for correct operation.
  - ▼ Test ride the motorcycle at low speeds.

## Table of Contents

Triumph Warranty Terms and Conditions.....	208
Conditions and Exclusions.....	209
Noise Control System Warranty .....	210
Tampering With The Noise Control System Prohibited.....	211
Emission Control System Warranty.....	212
California Emissions Control Warranty Statement.....	213
Manufacturers Warranty Coverage.....	214
Owners Warranty Responsibility.....	214
What is Covered by this Emission Warranty.....	216
What Is Not Covered By This Emission Warranty.....	217
Triumph Overseas .....	218
Caring for your Motorcycle.....	219

## Triumph Warranty Terms and Conditions

Thank you for choosing a Triumph motorcycle. This motorcycle is the product of Triumph's use of proven engineering, exhaustive testing, and continuous striving for superior reliability, safety, and performance.

This section of the Owner's Handbook includes details of the warranty and other useful information concerning your motorcycle.

Make sure that all your owner information is entered in the Triumph Motorcycle Service Handbook that is provided with the motorcycle.

Maintain maximum protection under warranty by making sure your motorcycle is serviced in accordance with the recommendations of the scheduled maintenance chart in this Owner's Handbook.

**If you should sell your motorcycle, make sure this Owner's Handbook or Quick Start Guide (where supplied with the motorcycle) together with all other relevant documents are passed to the new owner. Please advise the new owner that they can notify Triumph of the change of ownership by completing the form found on the Triumph web site at [www.triumphmotorcycles.com](http://www.triumphmotorcycles.com).**

All new Triumph motorcycles are covered by a 24 (Twenty-four) month unlimited mileage warranty, commencing from the date of first registration or the date of sale if the motorcycle remains unregistered.

Within the warranty period, TRIUMPH MOTORCYCLES AMERICA LIMITED warrant the new Triumph motorcycle detailed in the Motorcycle Service Handbook to be free from any defect in materials used in the manufacture, and/or workmanship at the time of its manufacture.

Any part found to be defective during this period will be repaired or replaced at the discretion of TRIUMPH MOTORCYCLES AMERICA LIMITED by an authorized Triumph dealer.

Any part replaced under the warranty will be covered for the remaining period of the warranty.

Any parts replaced under warranty must be returned to TRIUMPH MOTORCYCLES AMERICA LIMITED and will become the property of TRIUMPH MOTORCYCLES AMERICA LIMITED.

TRIUMPH MOTORCYCLES AMERICA LIMITED may, at its discretion make any repairs or replacement of defective parts falling outside the warranty, but such work shall not be deemed to be any admission of liability.

TRIUMPH MOTORCYCLES AMERICA LIMITED will bear labor charges for work carried out under the warranty.

The warranty may be transferred to subsequent owners for the balance of the remaining warranty period.



## Conditions and Exclusions

- ▼ The motorcycle must not have been used for competition, misused<sup>1</sup>, inadequately or incorrectly serviced or maintained.
- ▼ The motorcycle must not have been subject to any modification, repair or replacement other than as authorized by TRIUMPH MOTORCYCLES AMERICA LIMITED.
- ▼ The motorcycle battery is warranted for 12 (twelve) months from the original date of purchase of the motorcycle. After this 12 (twelve) month period, the battery is excluded from the terms of this warranty. The battery supplied with the motorcycle must be provided with sufficient charge to replenish that lost by the operation of the starting mechanism and/or the use of electrical equipment while the engine is not running. If the motorcycle is placed in to storage, remove the battery, and store it where it will not be exposed to direct sunlight, moisture, or freezing temperatures. During storage it should be given a slow charge (one Ampere or less) approximately once every two weeks.

## The warranty does not cover:

- ▼ The cost of transportation of the motorcycle to or from the authorized Triumph dealer, or expenses incurred while the motorcycle is off the road for warranty repairs.
- ▼ Defects caused by the use of parts and accessories not authorized by TRIUMPH MOTORCYCLES AMERICA LIMITED
- ▼ Defects caused by faulty adjustment, or repairs and alterations performed by a NON-AUTHORIZED Triumph dealer
- ▼ The cost of removal and replacement of parts and accessories, unless supplied as original equipment, or recommended by TRIUMPH MOTORCYCLES AMERICA LIMITED.
- ▼ Normal servicing and normal service items, such as spark plugs, oil and air filters are not covered by this warranty. Similarly items which are expected to wear as part of their normal function such as tires, bulbs, chains, brake pads and clutch plates are also excluded, unless there is a manufacturing defect.
- ▼ Defects to the front fork oil seals as they are subject to wear and tear, including but not limited to damage caused by stone chips to the inner fork tubes.

<sup>1</sup> Misuse includes any use not in accordance with the recommendations made in the 'how to ride the motorcycle' section of the Owner's Handbook and any use contrary to the warnings given in that same handbook. In addition, misuse will include, but not be limited to any use of the motorcycle which does not constitute normal road use.

## WARRANTY

- ▼ Seats, luggage, paint, chrome, polished aluminum items, or trim deterioration caused by normal wear and tear, exposure or lack of correct maintenance.
- ▼ Motorcycles used on a commercial basis.
- ▼ Defects which have not been reported to an authorized dealer within ten days of discovery of the defect.
- ▼ Motorcycles which have been inadequately lubricated, or for which the wrong fuel or lubricant has been used.

Should a warranty claim become necessary, TRIUMPH MOTORCYCLES AMERICA LIMITED and its authorized dealers shall not be liable for loss of use, inconvenience, lost time, commercial losses or other incidental or consequential damages.

Any statement, condition, representation, description or warranty otherwise contained in any catalog, advertisement or other publication shall not be construed as enlarging, varying or overriding anything contained herein.

TRIUMPH MOTORCYCLES AMERICA LIMITED reserve the right to make alterations or improvements without notification to any model or motorcycle without obligation to do so to motorcycles already sold.

This warranty does not affect your statutory rights.

## Noise Control System Warranty

### WARNING

This product should be checked for repair or replacement if the motorcycle noise has increased significantly through use, otherwise the owner may become subject to penalties under state and local ordinances.

The following warranty applies to the noise control system and is in addition to the general Triumph warranty and the emission control warranty.

Per 40 C.F.R. § 205.173-1, Triumph Motorcycles America Limited, warrants that this exhaust system, at the time of sale, meets all applicable U.S. E.P.A. federal noise standards. This warranty extends to the first person who buys this exhaust system for purposes other than resale, and to all subsequent buyers. Warranty claims should be directed to an authorized Triumph Motorcycles America dealer.

Triumph Motorcycles America Limited warrants to the first, and each subsequent owner, that the vehicle was designed and built so as to conform, at the time of sale, with the regulations of the U.S. Environmental Protection Agency (as tested following F-76 Drive-By test procedure) and, at the time of manufacture, was free from defects in materials and workmanship which would cause the motorcycle not to meet the U.S. Environmental Protection Agency Standards. This noise control system warranty extends for a period of 1 calendar year or 3,730 miles whichever occurs first from the date on which the

motorcycle was delivered to the first retail purchaser or, in the case of a demonstration motorcycle or company motorcycle, the date on which the company placed the motorcycle in service prior to retail sale.

## Tampering With The Noise Control System Prohibited

**Owners are warned that the law prohibits:**

- (a) The removal or rendering inoperative by any person other than for purposes of maintenance, repair or replacement, of any device or element of design incorporated into any new vehicle for the purpose of noise control prior to its sale or delivery to the ultimate purchaser or while it is in use and
- (b) the use of the vehicle after such device or element of design has been removed or rendered inoperative by any person.

Acts which are likely to constitute tampering include the following:

- ▼ Removal or tampering with the mufflers, baffles or header pipes or any other component which conducts exhaust gases.
- ▼ Removal of or puncturing of any part of the air intake system.
- ▼ Failure to carry out maintenance as prescribed in the owner's manual.
- ▼ Replacement of any parts of the exhaust or air intake system with parts other than those specified by Triumph Motorcycles America Limited.

## WARRANTY

The following items are not covered by the noise control system warranty:

- ▼ Failures which arise through misuse, alterations or accident damage.
- ▼ Replacing, removing, or modifications of any part of the noise control system (consisting of the exhaust system and air intake system) with parts not certified to be noise legal for street use.
- ▼ Triumph Motorcycles America Limited and its authorized dealers shall not be liable for loss of use, inconvenience, lost time, commercial losses or other incidental or consequential damages.
- ▼ Any motorcycle which has had the odometer recorded mileage changed so that the correct mileage of the motorcycle cannot be accurately determined.

### Emission Control System Warranty

The following warranty applies to the emission control system and is in addition to the general Triumph warranty and the noise control system warranty.

Triumph Motorcycles America Limited warrants to the first, and each subsequent owner, that the vehicle was designed and built so as to conform, at the time of sale, with the regulations of the U.S. Environmental Protection Agency and the California Air Resources Board and, at the time of manufacture, was free from defects in materials and workmanship which would cause the motorcycle not to meet the U.S. Environmental Protection Agency or California Air Resources Board Standards. This emission control system warranty extends for a period of 5 calendar years or 18,641 miles whichever occurs first, from the date on which the motorcycle was delivered to the first retail purchaser or, in the case of a demonstration motorcycle or company motorcycle, the date on which the company placed the motorcycle in service prior to retail sale.

**The following are not covered by the emission control system warranty:**

- ▼ Failures which arise through misuse, alterations, accident damage or failure to carry out maintenance as described in the owner's manual.
- ▼ The replacement of any parts required in the maintenance of the emission control system.
- ▼ Triumph Motorcycles America Limited and its authorized dealers shall not be liable for loss of use, inconvenience, lost time, commercial losses or other incidental or consequential damages.
- ▼ Any motorcycle which has had the odometer recorded mileage changed so that the correct mileage of the motorcycle cannot be accurately determined.

## **California Emissions Control Warranty Statement**

### **Your warranty rights and obligations**

The California Air Resources Board and Triumph Motorcycles America Limited are pleased to explain the emission control system on your motorcycle. In California, new motor vehicles must be designed, built and equipped to meet the State's stringent anti-smog standards. Triumph Motorcycles America Limited must warrant the emission control system on your motorcycle for the periods of time listed below provided there has been no abuse, neglect or improper maintenance of your vehicle.

Your emission control system may include parts such as the fuel injection and the ignition system. Also included may be hoses, connectors and other emission related assemblies.

Where a warrantable condition exists, Triumph Motorcycles America Limited will repair your motorcycle at no cost to you including diagnosis, parts and labor.

# WARRANTY

## Manufacturers Warranty Coverage

For a period of use of five years or 18,641 miles, whichever first occurs: If an emission related part on your motorcycle is defective, the parts will be repaired or replaced by Triumph Motorcycles America Limited. This is your emission control system DEFECTS WARRANTY.

## Owners Warranty Responsibility

As the motorcycle owner, you are responsible for the performance of the required maintenance listed in your owner's manual.

Triumph Motorcycles America Limited recommends that you retain all receipts covering maintenance on your motorcycle, but Triumph Motorcycles America Limited cannot deny warranty solely for the lack of receipts or for your failure to ensure the performance of all scheduled maintenance.

You are responsible for presenting your motorcycle to a Triumph Motorcycles America Limited dealer as soon as a problem exists. The warranty repairs should be completed in a reasonable amount of time, not to exceed 30 days.

As the motorcycle owner, you should also be aware that Triumph Motorcycles America Limited may deny you warranty coverage if your motorcycle or a part has failed due to abuse, neglect, improper maintenance or unapproved modifications.

If you have any questions regarding your warranty rights and responsibilities, you should contact Triumph Motorcycles America Limited, Warranty Service Department, 100 Hartsfield Centre Parkway, Suite 200, Atlanta, GA 30354, or the California Air Resources Board at 9528 Telstar Avenue, El Monte, California 91731.

Triumph Motorcycles America Limited warrants to the first, and each subsequent owner, that the vehicle was designed and built so as to conform, at the time of sale, with the regulations of the California Air Resources Board and, at the time of manufacture, was free from defects in materials and workmanship which would cause the motorcycle not to meet the California Air Resources Board Standards.

This warranty period starts the date the motorcycle is delivered to the first retail purchaser or, if the motorcycle is placed in service as a demonstrator or company motorcycle prior to sale at retail, the date it is first placed in service.

The emission control system of each new Triumph motorcycle was designed, built and tested using only genuine Triumph Motorcycle parts and with these parts the motorcycle is certified as being in conformity with California emission control regulations.

**WE RECOMMEND THAT ONLY GENUINE TRIUMPH MOTORCYCLE PARTS BE USED FOR MAINTENANCE REPAIR OR REPLACEMENT OF THE EMISSION CONTROL SYSTEM.** However, if you are willing to pay for it yourself, you can have replacement or repair of your motorcycle's emission control system performed by any qualified repair establishment or individual using non-genuine parts.

Remember: Use of replacement parts which are not equal in quality to genuine Triumph parts may impair the effectiveness of the emission control system or otherwise damage your motorcycle. If other than genuine Triumph parts are used for maintenance, replacement or repair of

components affecting emission control, you should obtain written assurances that such non-Triumph parts are warranted by their manufacturer to be equal in quality to genuine Triumph Motorcycle parts in both performance and durability. The use of non-Triumph replacement parts does not invalidate the warranty, if any, on other components unless the non-Triumph parts cause damage to warranted parts. However, we recommend that you go only to any authorized Triumph Motorcycle dealer for repairs under warranty, that has factory-trained mechanics and genuine parts. However, in the case of an "emergency" (as defined below) where an authorized Triumph dealer is not reasonably available, you could have repairs performed at any available service establishment or by the owner, using any replacement part. A part not being available within 30 days, or a repair not being complete within 30 days constitutes an emergency. Triumph Motorcycles America Limited will reimburse the owner for such repairs, including diagnosis, only if it is established that the repairs are covered under this emission warranty. Triumph Motorcycles America Limited parts reimbursement, however, will not exceed our suggested retail price for all warranted parts replaced and our labor reimbursement will be limited to our recommended time allowances for emission system repairs at the geographically appropriate hourly labor rate.

## WARRANTY

To obtain reimbursement from Triumph Motorcycles America Limited for such emergency repairs, you must keep all failed parts and original receipts, marked "paid," so you can present them to an authorized Triumph dealer for their inspection. Triumph Motorcycles America Limited recommends that you bring your motorcycle to an authorized dealer for inspection to ensure that the emergency repairs were done properly.

### What is Covered by this Emission Warranty

The emission control system warranty covers the following "warranted parts" only:

- ▼ Fuel injection/engine management equipment including oxygen sensors
- ▼ Intake manifold
- ▼ Air cleaner box
- ▼ Spark advance/retard system
- ▼ Spark plugs (first 10,000 miles)
- ▼ Ignition coils
- ▼ Charcoal canister
- ▼ Cap, fuel tank
- ▼ Fuel/vapor separator (fuel tank)
- ▼ Vapor valve
- ▼ Rollover/pressure control valves
- ▼ If used on the above systems: hoses, clamps, fittings, tubing, sealing gaskets and mounting hardware.



## What Is Not Covered By This Emission Warranty

The emission control system warranty does not cover:

Malfunctions in any "warranted parts" caused by any of the following: abuse, misuse, modification, alteration, tampering, disconnection, or improper or inadequate maintenance.

Damage resulting from accident, acts of nature or other events beyond the control of Triumph Motorcycles America Limited.

The repair or replacement of "warranted parts" which are scheduled for replacement prior to 18,641 miles (such as spark plugs, which are scheduled for replacement at 10,000 miles) once these parts have been replaced at the first replacement interval as part of required maintenance services.

Repairs and services performed by anyone other than an authorized Triumph dealer (except in case of emergency). The California Air Resources Board defines an "emergency" as an authorized dealer not being reasonably available or the lack of availability of "warranted parts" within a reasonable time period not to exceed 30 days.

Loss of time, inconvenience, loss of use of the motorcycle, or commercial loss.

Repairs on any motorcycle of which odometer mileage has been changed so that mileage cannot be really determined.

# WARRANTY

## Triumph Overseas

If you are traveling abroad and require assistance or advice from a Triumph dealer, contact the subsidiary or importer for the country which you are visiting.

Subsidiary offices are listed below.

For an up to date list of authorized Triumph dealers and importers, visit [www.triumphmotorcycles.co.uk](http://www.triumphmotorcycles.co.uk).

### Subsidiary Offices

#### Benelux

Triumph Netherlands

Tel: +31 725 41 0311

Email: [Benelux@Triumph.co.uk](mailto:Benelux@Triumph.co.uk)

#### Brazil

Triumph Motorcycles Brazil Ltda

Tel: +55 11 3010 1010

Email: [sac.triumph@europ-assistance.com.br](mailto:sac.triumph@europ-assistance.com.br)

#### China

British Triumph (Shanghai) Trading Co., Ltd.

Tel: +86 21 6140 9180

Email: [aftersales.china@triumphmotorcycles.com](mailto:aftersales.china@triumphmotorcycles.com)

#### Denmark/Finland/Norway/Sweden

Triumph Motorcycles AB

Tel: +46 8 680 68 00

Fax: +46 8 680 07 85

#### France

Triumph S.A.

Tel: +33 1 64 62 3838

Fax: +33 1 64 80 5828

#### Germany

Triumph Motorrad Deutschland GmbH

Tel: +49 6003 829090

Fax: +49 6003 8290927

#### India

Triumph Motorcycles (India) Private Limited

Tel: 1 800 3000 0051 (toll free)

Email: [customer.care@triumphmotorcycles.in](mailto:customer.care@triumphmotorcycles.in)

#### Italy

Triumph Motorcycles srl

Tel: +39 02 93 454525

Fax: +39 02 93 582575

#### Japan

Triumph Motorcycles Japan K.K.

Tel: +81 3 6453 9810

Fax: +81 3 6453 9811

#### Spain/Portugal

Triumph Motocicletas España, S.L

Tel: +34 91 637 7475

Fax: +34 91 636 1134

#### Thailand

Triumph Thailand

Tel: +66(0)20170333

Fax: +66(0)20170330

#### United Kingdom/Eire

Triumph Motorcycles Ltd

Tel: +44 1455 45 5012

Fax: +44 1455 45 2211

#### USA

Triumph Motorcycles (America) Ltd

Tel: +1 678 854 2010

Fax: +1 678 854 8740

## Caring for your Motorcycle

Triumph Motorcycles have taken great care in the selection of materials, plating and painting techniques so as to provide its customers with a quality cosmetic appearance allied to durability. However, motorcycles are often used in hostile environmental conditions and in these circumstances it is essential that the motorcycle is washed, dried and lost lubricity replaced to prevent discoloration particularly of plated and unplated metallic surfaces. Your dealer can provide further information and advice if required. Ultimately the appearance of your motorcycle will very much depend on the care it receives.

For further information in regards to caring for your motorcycle, refer to the Cleaning and Storage section of this Owner's Handbook.

This page intentionally left blank

## Street Triple RS

**Dimensions, Weights and Performance**

A list of model specific dimensions, weights and performance figures is available from your authorized Triumph dealer, or on the Internet at [www.triumph.co.uk](http://www.triumph.co.uk).

**Payload****Street Triple RS**

Maximum Payload

430 lb (195 kg)

**Engine****Street Triple RS**

Type

In-line 3 cylinder

Displacement

48.6 cu in (765 cc)

Bore x Stroke

3.07 x 2.10 in (77.99 x 53.38 mm)

Compression Ratio

12.54:1

Cylinder Numbering

Left to Right

Cylinder Sequence

1 at left

Firing Order

1-2-3

**Lubrication****Street Triple RS**

Lubrication System

Wet sump

Engine Oil Capacities:

Dry Fill

0.90 gallon (3.40 liters)

Oil/Filter Change

0.79 gallon (3.00 liters)

Oil Change Only

0.74 gallon (2.80 liters)

**Cooling System****Street Triple RS**

Coolant Type

Triumph HD4X Hybrid OAT coolant

Water/Antifreeze Ratio

50/50 (premixed as supplied by Triumph)

Coolant Capacity

0.56 gallon (2.13 liters)

Thermostat Opens (nominal)

160°F (71°C)

# SPECIFICATIONS

<b>Fuel System</b>	<b>Street Triple RS</b>
Type	Electronic fuel injection
Injectors	Solenoid operated
Fuel Pump	Submerged electric
Fuel Pressure (nominal)	50.8 lb/in <sup>2</sup> (3.5 bar)

<b>Fuel</b>	<b>Street Triple RS</b>
Type	AKI octane rating (R+M)/2 of 87 unleaded
Tank Capacity (motorcycle upright)	4.60 gallons (17.4 liters)

<b>Ignition</b>	<b>Street Triple RS</b>
Ignition System	Digital inductive
Electronic Rev Limiter	12,650r/min
Spark Plug	NGK CR9EIA9
Spark Plug Gap	0.03 in (0.9 mm)
Gap Tolerance	+0.00/-0.0039 in (+0.00/-0.1 mm)

Transmission	Street Triple RS
Transmission Type	6 speed, constant mesh
Clutch Type	Wet, multiplate
Final Drive Chain	RK XW-ring, 118 link
Primary Drive Ratio	1.85:1 (76/41)
Gear Ratios:	
Final Drive Ratio	2.88:1 (46/16)
1st	2.62:1 (34/13)
2nd	1.95:1 (39/20)
3rd	1.57:1 (36/23)
4th	1.35:1 (27/20)
5th	1.24:1 (26/21)
6th	1.14:1 (25/22)

### WARNING

Use the recommended tires **ONLY** in the combinations listed in the approved Tire Selector at [www.triumph.co.uk](http://www.triumph.co.uk).

Do not mix tires from different manufacturers or mix different specification tires from the same manufacturers.

Using/mixing tires may affect the handling, stability, braking and traction control (if equipped) functions of the motorcycle.

Failure to follow the advice above may lead to loss of motorcycle control which could result in serious injury or death.

### Approved Tires

A list of approved tires specific to these models is available from your authorized Triumph dealer, or on the Internet at [www.triumph.co.uk](http://www.triumph.co.uk).

# SPECIFICATIONS

<b>Tires</b>		<b>Street Triple RS</b>
Tire Sizes:		
Front	120/70 ZR17 58W	
Rear	180/55 ZR17 73W	
Tire Pressures (Cold):		
Front	33.9 lb/in <sup>2</sup> (2.34 bar)	
Rear	42 lb/in <sup>2</sup> (2.9 bar)	
<b>Electrical Equipment</b>		<b>Street Triple RS</b>
Battery Type	YTX-9BS	
Battery Rating	12 Volt, 8 Ah	
Alternator	14 Volt, 34 Amp at 5,000 rpm	
Headlight	LED	
Front Position Light	LED	
Tail/Brake Light	LED	
License Plate Light	12 Volt, 5 Watt	
Turn Signal Lights	12 Volt, 10 Watt	
Models with LED Turn Signal Lights	LED	
<b>Frame</b>		<b>Street Triple RS</b>
Rake	23.9°	
Trail	3.94 in (100 mm)	



**Tightening Torques**

Battery Terminals	39.8 lbf in (4.5 Nm)
Chain Adjuster Lock Nuts	15 lbf ft (20 Nm)
Chain Guard	80 lbf in (9 Nm)
Clutch Lever Nut	30.1 lbf in (3.5 Nm)
Oil Filter	89 lbf in (10 Nm)
Spark Plug	9 lbf ft (12 Nm)
Sump Plug	18 lbf ft (25 Nm)
Rear Wheel Spindle Nut	81 lbf ft (110 Nm)

**Fluids and Lubricants**

Bearings and Pivots	Grease to NLGI 2 specification
Brake Fluid	DOT 4 brake fluid
Coolant	Triumph HD4X Hybrid OAT coolant (pre-mixed)
Drive Chain	Chain spray suitable for XW-ring chains
Engine Oil	Semi or fully synthetic 10W/40 or 10W/50 motorcycle engine oil which meets specification API SH (or higher) and JASO MA, such as Castrol Power 1 Racing 4T 10W-40 (fully synthetic) engine oil, sold as Castrol Power RS Racing 4T 10W-40 (fully synthetic) in some countries.

This page intentionally left blank

**Street Triple S (40.2 cu in (660 cc))****Dimensions, Weights and Performance**

A list of model specific dimensions, weights and performance figures is available from your authorized Triumph dealer, or on the Internet at [www.triumph.co.uk](http://www.triumph.co.uk).

**Payload Street Triple S (40.3 cu in (660 cc))**

Maximum Payload	430 lb (195 kg)
-----------------	-----------------

**Engine Street Triple S (40.3 cu in (660 cc))**

Type	In-line 3 cylinder
Displacement	40.3 cu in (660 cc)
Bore x Stroke	2.99 x 1.91 in (76 x 48.48mm)
Compression Ratio	12.47:1
Cylinder Numbering	Left to Right
Cylinder Sequence	1 at left
Firing Order	1-2-3

**Lubrication Street Triple S (40.3 cu in (660 cc))**

Lubrication System	Wet sump
Engine Oil Capacities:	
Dry Fill	0.90 gallons (3.40 liters)
Oil/Filter Change	0.79 gallons (3.00 liters)
Oil Change Only	0.74 gallons (2.80 liters)

**Cooling System Street Triple S (40.3 cu in (660 cc))**

Coolant Type	Triumph HD4X Hybrid OAT coolant
Water/Antifreeze Ratio	50/50 (premixed as supplied by Triumph)
Coolant Capacity	0.56 gallons (2.13 liters)
Thermostat Opens (nominal)	160°F (71°C)

## SPECIFICATIONS

<b>Fuel System</b>	<b>Street Triple S (40.3 cu in (660 cc))</b>
Type	Electronic fuel injection
Injectors	Solenoid operated
Fuel Pump	Submerged electric
Fuel Pressure (nominal)	50.8 lb/in <sup>2</sup> (3.5 bar)

<b>Fuel</b>	<b>Street Triple S (40.3 cu in (660 cc))</b>
Type	91 RON unleaded
Tank Capacity (motorcycle upright)	4.6 gallons (17.4 liters)

<b>Ignition</b>	<b>Street Triple S (40.3 cu in (660 cc))</b>
Ignition System	Digital inductive
Electronic Rev Limiter	12,650 r/min
Spark Plug	NGK CR9EIA9
Spark Plug Gap	0.04 in (0.9 mm)
Gap Tolerance	+0.00/-0.004 in (+0.00/-0.1 mm)

Transmission	Street Triple S (40.3 cu in (660 cc))
Transmission Type	6 speed, constant mesh
Clutch Type	Wet, multiplate
Final Drive Chain	RK XW-ring, 118 link
Primary Drive Ratio	1.85:1 (76/41)
Gear Ratios:	
Final Drive Ratio	2.88:1 (46/16)
1st	2.62:1 (34/13)
2nd	1.95:1 (39/20)
3rd	1.57:1 (36/23)
4th	1.35:1 (27/20)
5th	1.24:1 (26/21)
6th	1.14:1 (25/22)

### WARNING

Use the recommended tires **ONLY** in the combinations listed in the approved Tire Selector at [www.triumph.co.uk](http://www.triumph.co.uk).

Do not mix tires from different manufacturers or mix different specification tires from the same manufacturers.

Using/mixing tires may affect the handling, stability, braking and traction control (if equipped) functions of the motorcycle.

Failure to follow the advice above may lead to loss of motorcycle control which could result in serious injury or death.

### Approved Tires

A list of approved tires specific to these models is available from your authorized Triumph dealer, or on the Internet at [www.triumph.co.uk](http://www.triumph.co.uk).

# SPECIFICATIONS

<b>Tires</b>		<b>Street Triple S (40.3 cu in (660 cc))</b>
Tire Sizes:		
Front	120/70 ZR17 58W	
Rear	180/55 ZR17 73W	
Tire Pressures (Cold):		
Front	34 lb/in <sup>2</sup> (2.34 bar)	
Rear	42 lb/in <sup>2</sup> (2.90 bar)	
<b>Electrical Equipment</b>		<b>Street Triple S (40.3 cu in (660 cc))</b>
Battery Type	YTX-9BS	
Battery Rating	12 Volt, 8 Ah	
Alternator	14 Volt, 34 Amp at 5,000 rpm	
Front Position Light	LED	
Headlight	LED	
Tail/Brake Light	LED	
License Plate Light	12 Volt, 5 Watt	
Turn Signal Lights	12 Volt, 10 Watt	
<b>Frame</b>		<b>Street Triple S (40.3 cu in (660 cc))</b>
Rake	24.1°	
Trail	3.92 in (99.6 mm)	

<b>Tightening Torques</b>		<b>Street Triple S (40.3 cu in (660 cc))</b>
Battery Terminals		39.8 lbf in (4.5 Nm)
Chain Adjuster Lock Nuts		15 lbf ft (20 Nm)
Chain Guard		80 lbf in (9 Nm)
Clutch Lever Nut		57.5 lbf in (3.5 Nm)
Oil Filter		89 lbf in (10 Nm)
Spark Plug		9 lbf ft (12 Nm)
Sump Plug		18 lbf ft (25 Nm)
Rear Wheel Spindle Nut		81 lbf ft (110 Nm)

<b>Fluids and Lubricants</b>	
Bearings and Pivots	Grease to NLGI 2 specification
Brake Fluid	DOT 4 brake fluid
Coolant	Triumph HD4X Hybrid OAT coolant (pre-mixed)
Drive Chain	Chain spray suitable for XW-ring chains
Engine Oil	Semi or fully synthetic 10W/40 or 10W/50 motorcycle engine oil which meets specification API SH (or higher) and JASO MA, such as Castrol Power 1 Racing 4T 10W-40 (fully synthetic) engine oil, sold as Castrol Power RS Racing 4T 10W-40 (fully synthetic) in some countries.

This page intentionally left blank



## Street Triple R and Street Triple R - LRH

**Dimensions, Weights and Performance**

A list of model specific dimensions, weights and performance figures is available from your authorized Triumph dealer, or on the Internet at [www.triumph.co.uk](http://www.triumph.co.uk).

Payload	Street Triple R	Street Triple R - LRH
Maximum Payload	430 lb (195 kg)	375 lb (170 kg)

Engine	Street Triple R	Street Triple R - LRH
Type	In-line 3 cylinder	In-line 3 cylinder
Displacement	48.6 cu in (765 cc)	48.6 cu in (765 cc)
Bore x Stroke	3.07 x 2.10 in (77.99 x 53.38 mm)	3.07 x 2.10 in (77.99 x 53.38 mm)
Compression Ratio	12.54:1	12.54:1
Cylinder Numbering	Left to Right	Left to Right
Cylinder Sequence	1 at left	1 at left
Firing Order	1-2-3	1-2-3

Lubrication	Street Triple R	Street Triple R - LRH
Lubrication System	Wet sump	Wet sump
Engine Oil Capacities:		
Dry Fill	0.90 gallon (3.40 liters)	0.90 gallon (3.40 liters)
Oil/Filter Change	0.79 gallon (3.00 liters)	0.79 gallon (3.00 liters)
Oil Change Only	0.74 gallon (2.80 liters)	0.74 gallon (2.80 liters)

## SPECIFICATIONS

Cooling System	Street Triple R	Street Triple R - LRH
Coolant Type	Triumph HD4X Hybrid OAT coolant	Triumph HD4X Hybrid OAT coolant
Water/Antifreeze Ratio	50/50 (premixed as supplied by Triumph)	50/50 (premixed as supplied by Triumph)
Coolant Capacity	0.56 gallon (2.13 liters)	0.56 gallon (2.13 liters)
Thermostat Opens (nominal)	160°F (71°C)	160°F (71°C)

Fuel System	Street Triple R	Street Triple R - LRH
Type	Electronic fuel injection	Electronic fuel injection
Injectors	Solenoid operated	Solenoid operated
Fuel Pump	Submerged electric	Submerged electric
Fuel Pressure (nominal)	50.8 lb/in <sup>2</sup> (3.5 bar)	50.8 lb/in <sup>2</sup> (3.5 bar)

Fuel	Street Triple R	Street Triple R - LRH
Type	AKI octane rating (R+M)/2 of 87 unleaded	AKI octane rating (R+M)/2 of 87 unleaded
Tank Capacity (motorcycle upright)	4.60 gallons (17.4 liters)	4.60 gallons (17.4 liters)

Ignition	Street Triple R	Street Triple R - LRH
Ignition System	Digital inductive	Digital inductive
Electronic Rev Limiter	12,650r/min	12,650r/min
Spark Plug	NGK CR9EIA9	NGK CR9EIA9
Spark Plug Gap	0.03 in (0.9 mm)	0.03 in (0.9 mm)
Gap Tolerance	+0.00/-0.0039 in (+0.00/-0.1 mm)	+0.00/-0.0039 in (+0.00/-0.1 mm)

Transmission	Street Triple R	Street Triple R - LRH
Transmission Type	6 speed, constant mesh	6 speed, constant mesh
Clutch Type	Wet, multiplate	Wet, multiplate
Final Drive Chain	RK XW-ring, 118 link	RK XW-ring, 118 link
Primary Drive Ratio	1.85:1 (76/41)	1.85:1 (76/41)
Gear Ratios:		
Final Drive Ratio	2.88:1 (46/16)	2.88:1 (46/16)
1st	2.62:1 (34/13)	2.62:1 (34/13)
2nd	1.95:1 (39/20)	1.95:1 (39/20)
3rd	1.57:1 (36/23)	1.57:1 (36/23)
4th	1.35:1 (27/20)	1.35:1 (27/20)
5th	1.24:1 (26/21)	1.24:1 (26/21)
6th	1.14:1 (25/22)	1.14:1 (25/22)

### WARNING

Use the recommended tires **ONLY** in the combinations listed in the approved Tire Selector at [www.triumph.co.uk](http://www.triumph.co.uk).

Do not mix tires from different manufacturers or mix different specification tires from the same manufacturers.

Using/mixing tires may affect the handling, stability, braking and traction control (if equipped) functions of the motorcycle.

Failure to follow the advice above may lead to loss of motorcycle control which could result in serious injury or death.

### Approved Tires

A list of approved tires specific to these models is available from your authorized Triumph dealer, or on the Internet at [www.triumph.co.uk](http://www.triumph.co.uk).

## SPECIFICATIONS

Tires	Street Triple R	Street Triple R - LRH
Tire Sizes:		
Front	120/70 ZR17 58W	120/70 ZR17 58W
Rear	180/55 ZR17 73W	180/55 ZR17 73W
Tire Pressures (Cold):		
Front	33.9 lb/in <sup>2</sup> (2.34 bar)	33.9 lb/in <sup>2</sup> (2.34 bar)
Rear	42 lb/in <sup>2</sup> (2.9 bar)	42 lb/in <sup>2</sup> (2.90 bar)
Electrical Equipment	Street Triple R	Street Triple R - LRH
Battery Type	YTX-9BS	YTX-9BS
Battery Rating	12 Volt, 8 Ah	12 Volt, 8 Ah
Alternator	14 Volt, 34 Amp at 5,000 rpm	14 Volt, 34 Amp at 5,000 rpm
Front Position Light	LED	LED
Headlight	LED	LED
Tail/Brake Light	LED	LED
License Plate Light	12 Volt, 5 Watt	12 Volt, 5 Watt
Turn Signal Lights	12 Volt, 10 Watt	12 Volt, 10 Watt
Models with LED Turn Signal Lights	LED	LED
Frame	Street Triple R	Street Triple R - LRH
Rake	23.9°	23.9°
Trail	3.94 in (100 mm)	3.94 in (100 mm)

**Tightening Torques**

Battery Terminals	39.8 lbf in (4.5 Nm)
Chain Adjuster Lock Nuts	15 lbf ft (20 Nm)
Chain Guard	80 lbf in (9 Nm)
Clutch Lever Nut	30.1 lbf in (3.5 Nm)
Oil Filter	89 lbf in (10 Nm)
Spark Plug	9 lbf ft (12 Nm)
Sump Plug	18 lbf ft (25 Nm)
Rear Wheel Spindle Nut	81 lbf ft (110 Nm)

**Fluids and Lubricants**

Bearings and Pivots	Grease to NLGI 2 specification
Brake Fluid	DOT 4 brake fluid
Coolant	Triumph HD4X Hybrid OAT coolant (pre-mixed)
Drive Chain	Chain spray suitable for XW-ring chains
Engine Oil	Semi or fully synthetic 10W/40 or 10W/50 motorcycle engine oil which meets specification API SH (or higher) and JASO MA, such as Castrol Power 1 Racing 4T 10W-40 (fully synthetic) engine oil, sold as Castrol Power RS Racing 4T 10W-40 (fully synthetic) in some countries.

This page intentionally left blank

- A**
- Accessories ..... 133
- B**
- Bank Angle Indicators ..... 182
  - Battery
    - Charging..... 190
    - Discharge..... 189
    - Disposal..... 189
    - Installation..... 191
    - Maintenance..... 189
    - Removal..... 189
    - Storage..... 190
  - Brake Lever
    - Adjustment - Street Triple (40.3 cu in (660 cc))..... 32
    - Adjustment - Street Triple RS ..... 31
  - Brakes..... 159
    - Breaking-in New Brake Discs and Pads.. 159
    - Disc Brake Fluid..... 163
    - Front Brake Fluid Adjustment..... 164, 165
    - Front Brake Fluid Inspection..... 164, 165
    - Front Brake Fluid Reservoir ..... 164, 165
    - Front Brake Wear Inspection..... 160
    - Light Switches ..... 167
    - Pad Wear Compensation..... 160
    - Rear Brake Fluid Level Adjustment..... 167
    - Rear Brake Fluid Level Inspection..... 166
    - Rear Brake Fluid Reservoir..... 166
    - Rear Brake Wear Inspection..... 161
  - Breaking-In..... 118
- C**
- Cleaning
    - After Washing..... 200
    - Aluminum Items - not Lacquered or Painted..... 200
    - Black Chrome Items..... 201
    - Care of Leather Products..... 204
    - Chrome and Stainless Steel..... 201
    - Exhaust System..... 202
    - Frequency of Cleaning..... 198
    - Gloss Paintwork ..... 200
    - Matt Paintwork ..... 200
    - Preparation for Washing ..... 198
    - Seat Care..... 202
    - Washing ..... 199
    - Where to be Careful..... 199
    - Windshield ..... 203
  - Cleaning and Storage..... 198
  - Clock
    - Adjustment..... 87
  - Clutch..... 154
    - Adjustment..... 155
    - Inspection ..... 154
  - Clutch Lever
    - Adjustment - Street Triple (40.3 cu in (660 cc))..... 33
    - Adjustment - Street Triple RS ..... 33
  - Cooling System..... 150
    - Coolant Change ..... 152
    - Coolant Level Adjustment..... 152
    - Coolant Level Inspection..... 151
    - Corrosion Inhibitors..... 151
    - High Coolant Temperature Warning Light 79
    - Specifications..... 221, 227, 234
- D**
- Daytime Running Lights (DRL)..... 37, 45
  - Drive Chain ..... 156
    - Free Movement Adjustment ..... 157
    - Free Movement Inspection..... 157
    - Lubrication..... 156
    - Wear Inspection ..... 159
- E**
- Electrical Equipment
    - Specifications..... 224, 230, 236
  - Engine
    - Moving Off ..... 123
    - Specifications..... 221, 227, 233
    - To Start the Engine..... 123
    - To Stop the Engine ..... 122
  - Engine Immobilizer / Indicator Light..... 80
  - Engine Oil..... 147
    - Oil and Oil Filter Change..... 149
    - Oil Level Inspection..... 148
    - Specification and Grade..... 150
  - Engine Start/Stop Switch
    - RUN Position..... 34, 35

- START Position ..... 34, 35
- STOP Position ..... 34, 35
- F**
- Fluids
  - Specifications ..... 225, 231, 237
- Frame
  - Specifications ..... 224, 230, 236
- Front Fork Inspection ..... 172
- Front Suspension Settings
  - Street Triple R ..... 174
  - Street Triple R - LRH ..... 173
  - Street Triple RS ..... 174
- Fuel ..... 105
  - Filling the Fuel Tank ..... 108
  - Fuel Grade ..... 105
  - Fuel Tank Cap ..... 108
  - Low Fuel Warning Light ..... 46, 82
  - Refueling ..... 107
  - Specifications ..... 222, 228, 234
  - System Specifications ..... 222, 228, 234
- Fuses
  - Identification ..... 192
  - Location ..... 192
- G**
- Gear Shift Lights ..... 89
- Gears
  - Shifting Gears ..... 124
- H**
- Handbook and Tool Kit
  - Handbook ..... 116
  - Tool Kit ..... 116
- Hazards
  - Warning Lights ..... 34, 45
- Headlight
  - Adjustment ..... 194
  - Replacement ..... 194
- Headlight(s) ..... 193
- High Beam Warning Light ..... 45
- High Speed Operation ..... 131
- HOME Button ..... 34
- I**
- Ignition
  - Ignition Switch/Steering Lock ..... 29
  - Specifications ..... 222, 228, 234
- Immobilizer
  - Indicator Light ..... 43
- Instruments
  - Description ..... 39
  - Speedometer ..... 84
  - Tachometer ..... 84
- Instruments - TFT
  - Instruments Display Layout ..... 42
- L**
- Lap Timer ..... 94
  - Accessing ..... 94
  - Data Recording Mode ..... 95
  - Data Retrieval Mode ..... 96
  - Reset ..... 97
- LCD Instruments
  - Changing Units ..... 90
  - Clock Adjustment ..... 87
  - Coolant Temperature Gage ..... 85
  - Fuel Gage ..... 85
  - Gear Position Display ..... 84
  - Gear Shift Lights ..... 89
  - Instrument Panel Layout ..... 78
  - Rain Mode ..... 98
  - Riding Mode Selection ..... 97, 102, 104
  - ROAD Mode ..... 98
  - SCROLL Button ..... 86
  - Service Interval Announcement (SIA) ..... 88
  - SET Button ..... 86
  - Traction Control (TC) Disable ..... 86
  - Trip Meter ..... 92
- Left Handlebar Switches
  - Except Street Triple RS ..... 38
  - High Beam Button ..... 38
  - High Beam Button (DRL) ..... 37
  - Horn Button ..... 36, 38
  - Mode Button ..... 36, 38
  - Street Triple RS ..... 36
  - Turn Signal Switch ..... 36, 38
- License Plate Light
  - Bulb Replacement ..... 196
- Lights
  - Hazards ..... 34, 45



- Tail Light..... 195
- Loading..... 135
- Low Ride Height Models..... 03
- Lubrication
  - Specifications..... 221, 227, 233
- M**
- Maintenance
  - Scheduled Maintenance..... 142
- Mirrors..... 167, 168
  - Bar End Mirrors..... 168
- P**
- Parking..... 130
- Parts Identification
  - Left Hand Side..... 18
  - Rider View..... 20, 21
  - Right Hand Side..... 19
- Passengers..... 136
- Payload
  - Specifications..... 221, 227, 233
- R**
- Rear Suspension Settings..... 176
  - Street Triple R..... 177
  - Street Triple R - LRH..... 177
  - Street Triple RS..... 178
  - Street Triple S (40.3&nbsp;cu&nbsp;in (660&nbsp;cc))..... 178
- Riding Modes..... 53
  - Configuration..... 57
  - RIDER Mode..... 99
  - Selection..... 54
  - Setting the RIDER Mode Options..... 100
  - SPORT Mode..... 98
- Right Handlebar Switches
  - Except Street Triple RS..... 35
  - Hazard Switch..... 35, 82
  - HOME Button..... 34
  - Street Triple RS..... 34
- S**
- Safety
  - Daily Safety Checks..... 119
  - Fuel and Exhaust Fumes..... 09, 122, 147
  - Handlebars and Footrests..... 15, 000
  - Helmet and Clothing..... 10
  - Maintenance and Equipment..... 12
  - Parking..... 11
  - Parts and Accessories..... 11, 133
  - Riding..... 13
    - The Motorcycle..... 08
  - Scheduled Maintenance
    - Disposal of Used Fluids..... 144
    - Scheduled Maintenance Table..... 145
  - Seats
    - Rider's Seat..... 114
    - Seat Care..... 114, 202
    - Seat Lock..... 115
  - Serial Numbers
    - Engine Serial Number..... 23
    - Vehicle Identification Number..... 23
  - Service Interval Announcement (SIA)..... 88
  - Side Stand..... 113
  - Specifications
    - Street Triple R..... 233
    - Street Triple R - LRH..... 233
    - Street Triple RS..... 221
    - Street Triple S (40.3&nbsp;cu&nbsp;in (660&nbsp;cc))..... 227
  - Steering
    - Front Fork Inspection..... 172
    - Inspection..... 169
    - Wheel Bearing Inspection..... 170
  - Steering/Wheel Bearings..... 169
  - Storage
    - Preparation after Storage..... 206
    - Preparation for Storage..... 205
  - Suspension
    - Front Suspension..... 173
    - Rear Suspension..... 176
  - Suspension Adjustment
    - Front Suspension - Street Triple R and Street Triple R (LRH)..... 174, 175
    - Front Suspension - Street Triple RS..... 175, 176
    - Rear Suspension - Street Triple R.... 179, 180
    - Rear Suspension - Street Triple R (LRH)..... 178, 181
    - Rear Suspension - Street Triple RS... 180, 181
    - Street Triple S (40.3 cu in (660 cc))..... 179

- T**
- Tail Light..... 195
  - TFT Digital Display
    - Main Menu - Display Set Up - Gear Shift Ind..... 65
  - TFT Instruments
    - Ambient Air Temperature ..... 50
    - Bike Set Up Menu ..... 57
    - Coolant Temp Gage..... 50
    - Display Navigation..... 52
    - Display Set Up Menu..... 61
    - Frost Symbol..... 51
    - Fuel Gage ..... 49
    - Gear Position Display..... 51
    - Information Tray ..... 69
    - Instrument Display Layout..... 41
    - Lap Timer Menu ..... 66
    - Main Menu..... 55
    - Odometer ..... 48
    - Panel Adjustment ..... 76
    - Reset to Defaults..... 68
    - Riding Mode Selection ..... 54
    - Riding Modes ..... 53, 56
    - Riding Modes Configuration..... 57
    - Speedometer..... 48
    - Styles ..... 52
    - Tachometer..... 49
    - Trip Set Up Menu ..... 59
    - Warning and Information Messages..... 47
  - Throttle Control..... 28, 153
    - Inspection ..... 154
  - Tire Pressure Monitoring System (TPMS)..... 110
    - Replacement Tires..... 113
    - Sensor Batteries ..... 113
    - Sensor Serial Number ..... 111
    - Tire Pressure Warning Light ..... 46, 83, 110
    - Tire Pressures ..... 112, 184
  - Tires
    - Minimum Tread Depth ..... 185
    - Replacement..... 113, 185
    - Specifications..... 224, 230, 236
    - Tire Inflation Pressures..... 183
    - Tire Type ..... 182
    - Tire Wear ..... 184
  - Torque Specifications..... 225, 231, 237
  - Traction Control (TC)..... 109
    - Disabled Warning Light ..... 45
    - Settings..... 109
  - Transmission
    - Specifications..... 223, 229, 235
  - Left Handlebar Switches..... 38
  - Triumph Shift Assist (TSA)..... 125
  - Turn Signals
    - Bulb Replacement..... 195
    - LED Units ..... 195
    - Warning Light..... 45

**U**

    - Universal Serial Bus (USB) Socket..... 117

**W**

    - Warning Lights
      - Daytime Running Lights (DRL) (if equipped) ..... 45
      - Engine Management System Malfunction Indicator Light (MIL)..... 42, 79
      - High Beam Light ..... 82
      - Low Fuel Warning Light ..... 46, 82
      - Low Oil Pressure Warning Light ..... 42, 79
      - Neutral Light ..... 83
      - Traction Control (TC) Disabled Warning Light..... 82
      - Traction Control (TC) Indicator Light... 44, 81
      - Turn signal Light..... 82
    - Warnings..... 03
      - Immobilizer and TPMS..... 245
      - Maintenance ..... 04
      - Noise Control System..... 04
      - Owner's Handbook..... 05
      - Warning Label Locations ..... 16, 17
      - Warning Labels..... 03
      - Warning Lights..... 79
    - Wheels
      - Wheel Bearing Inspection..... 170
    - Windshield
      - Cleaning..... 203

This page intentionally left blank

## 244 **APPROVAL INFORMATION**

This section contains approval information that is required to be included in this Owner's Handbook.

## FCC Statement

This device complies with part 15 of the Federal Communications Commission (FCC) Rules.

Operation is subject to the following two conditions:

- ▼ This device may not cause harmful interference.
- ▼ This device must accept any interference received, including interference that may cause undesired operation.

Changes or modifications to the device could void the user's authority to operate the equipment.