

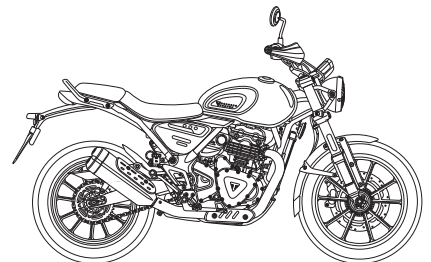

Speed 400 and Scrambler 400 X

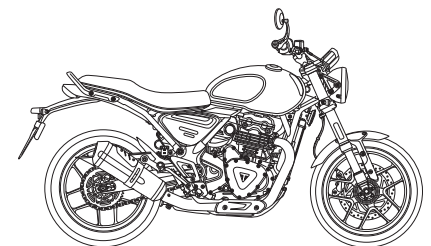

This handbook contains information on the Triumph Speed 400 and Scrambler 400 X motorcycles. Always store this Owner's Handbook with the motorcycle and refer to it for information whenever necessary.

The information contained in this publication is based on the latest information available at the time of printing. Triumph reserves the right to make changes at any time without prior notice, or obligation.

Not to be reproduced wholly or in part without the written permission of Triumph Motorcycles America Limited. Este Manual del propietario está disponible en español.

© Copyright 09.2023 Triumph Motorcycles America Limited.

Publication part number 3850291-US-EN issue 1

This handbook contains a number of different sections. The table of contents below will help you find the beginning of each section where, in the case of the major sections, a further table of contents will help you find the specific subject required.

- 03** FOREWORD
- 07** SAFETY FIRST
- 16** WARNING LABELS
- 18** PARTS IDENTIFICATION
- 23** SERIAL NUMBERS
- 25** INSTRUMENTS
- 41** GENERAL INFORMATION
- 65** HOW TO RIDE THE MOTORCYCLE
- 77** ACCESSORIES, LOADING AND PASSENGERS
- 83** MAINTENANCE AND ADJUSTMENT
- 137** CLEANING AND STORAGE
- 147** WARRANTY
- 159** SPECIFICATIONS
- 165** INDEX
- 169** APPROVAL INFORMATION

Owner's Handbook

WARNING

The Owner's Handbook or Quick Start Guide (where supplied with the motorcycle), and all other documents that are supplied with your motorcycle, should be considered a permanent part of your motorcycle and should remain with it even if your motorcycle is subsequently sold.

All riders must read the Owner's Handbook, Quick Start Guide, and all other documents which are supplied with your motorcycle, before riding, in order to become thoroughly familiar with the correct operation of your motorcycle's controls, its features, capabilities and limitations.

Do not lend your motorcycle to others as riding when not familiar with your motorcycle's controls, features, capabilities and limitations may lead to loss of motorcycle control which could result in serious injury or death.

Thank you for choosing a Triumph motorcycle. This motorcycle is the product of Triumph's use of proven engineering, exhaustive testing, and continuous striving for superior reliability, safety and performance.

Please read this Owner's Handbook before riding in order to become thoroughly familiar with the correct operation of your motorcycle's controls, its features, capabilities and limitations.

This Owner's Handbook includes safe riding tips, but does not contain all the techniques and skills necessary to ride a motorcycle safely.

Triumph strongly recommends that all riders undertake the necessary training to ensure safe operation of this motorcycle.

The latest version of this Owner's Handbook containing any changes is available from your local dealer and online from www.triumphmotorcycles.co.uk/handbooks in:

- ▼ English
- ▼ US English
- ▼ Arabic
- ▼ Chinese
- ▼ Dutch
- ▼ French
- ▼ German
- ▼ Italian
- ▼ Japanese
- ▼ Portuguese (Brazil)
- ▼ Spanish
- ▼ Swedish
- ▼ Thai
- ▼ Finnish (available online only from www.triumphmotorcycles.co.uk/handbooks)
- ▼ Portuguese (available online only from www.triumphmotorcycles.co.uk/handbooks).

The languages available for this Owner's Handbook are dependent on the specific motorcycle model and country.

FOREWORD

Dangers, Warnings, Cautions and Notices

Particularly important information is presented in the following form:

DANGER

This danger symbol identifies special instructions or procedures which, if not correctly followed, will result in serious injury, or death.

WARNING

This warning symbol identifies special instructions or procedures which, if not correctly followed, could result in serious injury, or death.

CAUTION

This caution symbol identifies special instructions or procedures which, if not strictly observed, could result in minor or moderate injury.

NOTICE

This notice symbol indicates points of particular interest for more efficient and convenient operation.

Warning Labels



At certain areas of the motorcycle, the symbol (above) can be seen. The symbol means CAUTION: REFER TO THE HANDBOOK and will be followed by a pictorial representation of the subject concerned and/or text.

Never attempt to ride the motorcycle or make any adjustments without reference to the relevant instructions contained in this handbook.

For the location of all labels showing this symbol, see the Warning Label Locations section of this Owner's Handbook. Where necessary, this symbol will also appear on the pages containing the relevant information.

Maintenance

To ensure a long, safe, and trouble-free life for your motorcycle, maintenance should only be carried out by a competent person with the specialist knowledge and technical understanding of motorcycles, such as an authorized Triumph dealer.

An authorized Triumph dealer will have the necessary knowledge, equipment, and skills to maintain your Triumph motorcycle correctly.

To locate your nearest authorized Triumph dealer, visit the Triumph web site at www.triumph.co.uk or telephone the authorized distributor in your country. Their address is given in the service record book that accompanies this handbook.

Noise Control System

Tampering with the noise control system is prohibited.

Owners are warned that the law may prohibit:

- ▼ The removal or rendering inoperative by any person other than for purposes of maintenance, repair or replacement, of any device or element of design incorporated into any new vehicle for the purpose of noise control prior to its sale or delivery to the ultimate purchaser or while it is in use and,
- ▼ The use of the vehicle after such device or element of design has been removed or rendered inoperative by any person.

Among those acts presumed to constitute tampering are the acts listed below:

- ▼ Removal of, or puncturing the muffler, baffles, header pipes or any other component which conducts exhaust gases.
- ▼ Removal of, or puncturing of any part of the intake system.
- ▼ Lack of proper maintenance.
- ▼ Replacing any moving parts of the vehicle, or parts of the exhaust or intake system, with parts other than those specified by the manufacturer.

Talk to Triumph

Our relationship with you does not end with the purchase of your Triumph. Your feedback on the buying and ownership experience is very important in helping us develop our products and services for you.

Please help us by ensuring your authorized Triumph dealership has your email address and registers this with us. You will then receive an online customer satisfaction survey invitation to your email address where you can give us this feedback.

Your Triumph Team.

Off-road Use

Scrambler 400 X Only

This motorcycle is designed for on-road and light off-road use. Light off-road use includes use on unpaved, dirt or gravel roads, but does not include riding on any motocross course, any off-road competition (such as motocross or enduro riding), or riding off-road with a passenger.

Light off-road use does not include jumping the motorcycle or riding over obstacles. Do not attempt to jump over any bumps or obstacles. Do not attempt to ride over any obstacles.

This page intentionally left blank

The Motorcycle

Speed 400

WARNING

This motorcycle is designed for on-road use only.

Do not ride this motorcycle off-road.

Off-road operation may lead to loss of motorcycle control which could result in serious injury or death.

Scrambler 400 X

WARNING

This motorcycle is designed for on-road and light off-road use. Light off-road use includes use on unpaved, dirt or gravel roads, but does not include riding on any motocross course, any off-road competition (such as motocross or enduro riding), or riding off-road with a passenger.

Light off-road use does not include jumping the motorcycle or riding over obstacles. Do not attempt to jump over any bumps or obstacles. Do not attempt to ride over any obstacles.

Extreme off-road use may lead to loss of motorcycle control which could result in serious injury or death.

All Models

WARNING

This motorcycle is designed for use as a two-wheeled vehicle capable of carrying a rider and up to one passenger (subject to a passenger seat and footrests being installed).

The total weight of the rider, and any passenger, accessories and luggage must not exceed the maximum load limit as specified in the Specifications section.

Failure to follow the advice above may lead to loss of motorcycle control which could result in serious injury or death.

WARNING

This motorcycle is not designed to tow a trailer or be equipped with a sidecar.

Mounting a sidecar and/or a trailer may affect the handling, stability or other aspect of the motorcycle operation.

Failure to follow the advice above may lead to loss of motorcycle control which could result in serious injury or death.

SAFETY FIRST

Fuel and Exhaust Fumes

DANGER

Never start the engine or run the engine in a confined area.

Always operate the motorcycle in the open air or in an area with adequate ventilation.

Exhaust fumes are poisonous and will cause loss of consciousness and death within a short period of time.

WARNING

GASOLINE IS HIGHLY FLAMMABLE:

- Always turn off the engine when refueling.
- Pay full attention and remain alert while refueling.
- Do not refuel or open the fuel filler cap while smoking or in the vicinity of any open (naked) flame.
- Take care not to spill any gasoline on the engine, exhaust pipes or mufflers when refueling.
- If gas is swallowed, inhaled or allowed to get into the eyes, seek immediate medical attention.
- Spillage on the skin should be immediately washed off with soap and water and clothing contaminated with gas should immediately be removed.
- Burns and other serious skin conditions may result from contact with gas.

Failure to follow the advice above could result in serious injury or death.

Helmet and Clothing



DANGER

A helmet is one of the most important pieces of riding gear as it offers protection against head injuries. You and your passenger's helmet should be carefully chosen and should fit you or your passenger's head comfortably and securely. A brightly colored helmet will increase a rider's (or passenger's) visibility to other operators of road vehicles.

An open face helmet offers some protection in an accident though a full face helmet will offer more.

Always wear a visor or approved goggles to help vision and to protect your eyes.

Failure to follow the advice above will result in serious injury or death.

⚠ WARNING

When riding the motorcycle, both rider and passenger (on models where carrying a passenger is permitted) must always wear appropriate clothing including a motorcycle helmet, eye protection, gloves, boots, trousers (close fitting around the knee and ankle) and a brightly colored jacket.

During off-road use (on models suitable for off-road use), the rider must always wear appropriate clothing including trousers and boots.

Brightly colored clothing will considerably increase a rider's (or passenger's) visibility to other operators of road vehicles.

Although full protection is not possible, wearing correct protective clothing can reduce the risk of serious injury or death.

When choosing a helmet, always look for a DOT (Department of Transport) sticker indicating that the helmet has DOT approval. Do not buy a helmet without DOT approval.

Maintenance and Equipment**⚠ WARNING**

Whenever there is doubt as to the correct or safe operation of this motorcycle, contact a competent person with the specialist knowledge and technical understanding of motorcycles, such as an authorized Triumph dealer.

Operation of an incorrectly performing motorcycle may aggravate a fault and may also compromise safety.

Continued operation of an incorrectly performing motorcycle may affect the handling, stability or other aspect of the motorcycle operation, leading to loss of motorcycle control which could result in serious injury or death.

⚠ WARNING

Make sure all equipment that is required by law is installed and functioning correctly.

The removal or alteration of the motorcycle's lights, mufflers, emission or noise control systems can violate the law.

Incorrect or improper modification may affect the handling, stability or other aspect of the motorcycle operation, leading to loss of motorcycle control which could result in serious injury or death.

SAFETY FIRST

WARNING

If the motorcycle is involved in an accident, collision or fall, it must be taken for inspection and repair.

Inspections and repairs must be completed by a competent person with the specialist knowledge and technical understanding of motorcycles, such as an authorized Triumph dealer.

Any accident can cause damage to the motorcycle that, if not correctly repaired, may cause a second accident which could result in serious injury or death.

Parking

WARNING

Always switch off the engine and remove the ignition key before leaving the motorcycle unattended. By removing the key, the risk of use of the motorcycle by unauthorized or untrained persons is reduced.

When parking the motorcycle, always remember the following:

- Engage first gear to help prevent the motorcycle from rolling off the stand.
- The engine, radiator, exhaust system, rear suspension unit and brakes will be hot after riding. DO NOT park where pedestrians, animals and/or children are likely to touch the motorcycle.
- Do not park on soft ground or on a steeply inclined surface. Parking under these conditions may cause the motorcycle to fall over.

For further details, refer to the How to Ride the Motorcycle section of this Owner's Handbook.

Failure to follow the advice above could result in damage to property, serious injury or death.

Riding

DANGER

Never ride the motorcycle when fatigued or under the influence of alcohol or other drugs.

Riding when under the influence of alcohol or other drugs is illegal.

Riding when fatigued or under the influence of alcohol or other drugs reduces the rider's ability to maintain control, leading to loss of motorcycle control which will result in serious injury or death.

WARNING

All riders must be licensed to operate the motorcycle.

Operation of the motorcycle without a license is illegal and could lead to prosecution.

Operation of the motorcycle without formal training in the correct riding techniques that are necessary to become licensed is dangerous.

Failure to follow the advice above may lead to loss of motorcycle control which could result in serious injury or death.

WARNING

Always ride defensively and wear the protective equipment mentioned elsewhere in this Safety First section.

Remember, in an accident, a motorcycle does not give the same impact protection as a car.

Failure to follow the advice above could result in serious injury or death.

WARNING

This motorcycle should be operated within the legal speed limits for the particular road traveled.

Riding a motorcycle at high speeds can be dangerous since the time available to react to a hazard is greatly reduced at high speeds.

Always reduce speed in potentially hazardous driving conditions such as bad weather or heavy traffic.

Failure to follow the advice above may lead to loss of motorcycle control which could result in serious injury or death.

 **WARNING**

Continually observe and react to changes in road surface, traffic and wind conditions. All two-wheeled vehicles are subject to external forces which may affect the handling, stability or other aspect of the motorcycle operation.

These forces include but are not limited to:

- Wind draft from passing vehicles
- Potholes, uneven or damaged road surfaces
- Bad weather
- Rider error.

Always operate the motorcycle at moderate speed and away from heavy traffic until you have become thoroughly familiar with its handling and operating characteristics. Never exceed the legal speed limit.

Failure to follow the advice above may lead to loss of motorcycle control which could result in serious injury or death.

Wobble/Weave

A weave is a relatively slow oscillation of the rear of the motorcycle, while a wobble is a rapid, possibly strong shaking of the handlebar. These are related but distinct stability problems usually caused by excessive weight in the wrong place, or by a mechanical problem such as worn or loose bearings or under-inflated or unevenly worn tires.

Your solution to both situations is the same. Keep a firm hold on the handlebars without locking arms or fighting the steering. Smoothly ease off the throttle to slow gradually. Do not apply the brakes, and do not accelerate to try to stop the wobble or weave. In some cases, it helps to shift your body weight forward by leaning over the tank.

Copyright © 2005 Motorcycle Safety Foundation. All rights reserved. Used with permission.

Handlebars and Footrests

WARNING

The rider must maintain control of the motorcycle by keeping hands on the handlebars at all times.

The handling and stability of a motorcycle will be affected if the rider removes their hands from the handlebars.

Failure to follow the advice above may lead to loss of motorcycle control which could result in serious injury or death.

WARNING

The rider and passenger (if applicable) must always use the footrests provided, during operation of the motorcycle.

By using the footrests, both rider and passenger will reduce the risk of inadvertent contact with any motorcycle components and will also reduce the risk of injury from entrapment of clothing.

Failure to follow the advice above may lead to loss of motorcycle control which could result in serious injury or death.

WARNING

When banking and the bank angle indicator, attached to the rider's footrest, makes contact with the ground, the motorcycle is nearing its bank angle limit.

A further increase of the banking angle is unsafe.

Banking to an unsafe angle may lead to loss of motorcycle control which could result in serious injury or death.

WARNING

The bank angle indicators must not be used as a guide to how far the motorcycle may be safely banked.

This depends on many various conditions including, but not limited to:

- Road surface
- Tire condition
- Weather.

Banking to an unsafe angle may lead to loss of motorcycle control which could result in serious injury or death.

WARNING

Always replace the bank angle indicators before they are worn to their maximum limit.

Use of a motorcycle with bank angle indicators worn beyond the maximum limit will allow the motorcycle to be banked to an unsafe angle.

Banking to an unsafe angle may lead to loss of motorcycle control which could result in serious injury or death.

SAFETY FIRST

Parts and Accessories

WARNING

Owners should be aware that the only approved parts, accessories and conversions for any Triumph motorcycle are those which carry official Triumph approval.

We recommend accessories and conversions be completed by a competent person with the specialist knowledge and technical understanding of motorcycles, such as an authorized Triumph dealer.

In particular, it is extremely hazardous to install or replace parts or accessories whose installation requires the dismantling of, or addition to, either the electrical or fuel systems and any such modification could cause a safety hazard.

The installation of any non-approved parts, accessories or conversions may affect the handling, stability or other aspect of the motorcycle operation, leading to loss of motorcycle control which could result in serious injury or death.

Triumph does not accept any liability whatsoever for defects caused by the installation of non-approved parts, accessories or conversions.

Triumph does not accept any liability whatsoever for defects caused by the incorrect installation of approved parts, accessories or conversions.

This page intentionally left blank

WARNING LABELS

Speed 400 shown

Left Hand Side

NOTICE

The labels detailed on this and the following pages draw your attention to important safety information in this handbook. Before riding, make sure that you have understood and complied with all the information to which these labels relate.

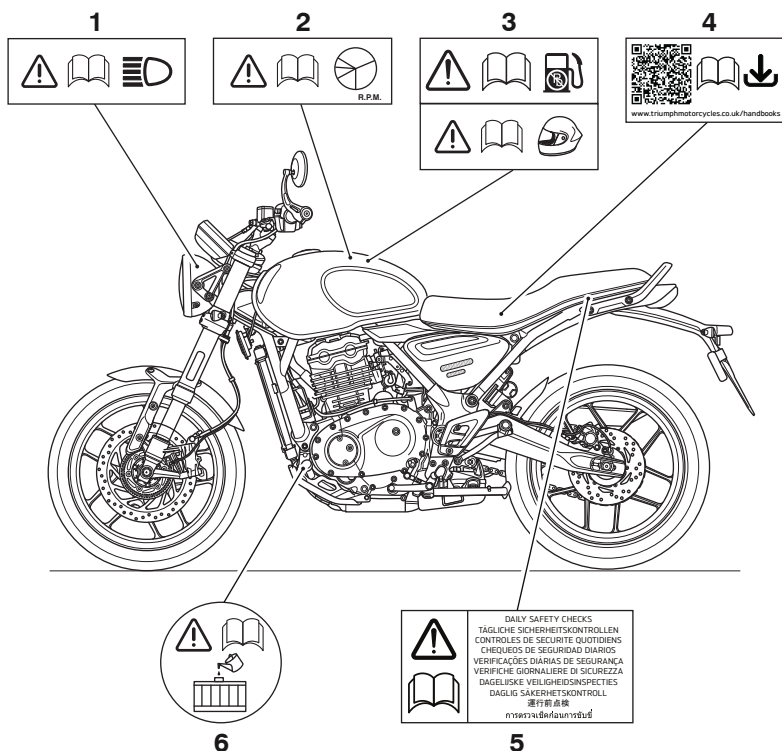

1. Headlight (page 133)
2. Breaking-In (page 63)
3. Unleaded Fuel (page 48) and Helmet (page 08)
4. Owner's Handbook Download Details (under seat)
5. Daily Safety Checks (page 64)
6. Coolant - Expansion Tank Cap (page 95)

Right Hand Side

NOTICE

All warning labels and decals, with the exception of the Breaking-in label, are mounted on the motorcycle using a strong adhesive. In some cases, labels are installed prior to an application of paint lacquer. Therefore, any attempt to remove the warning labels will cause damage to the paintwork or bodywork.

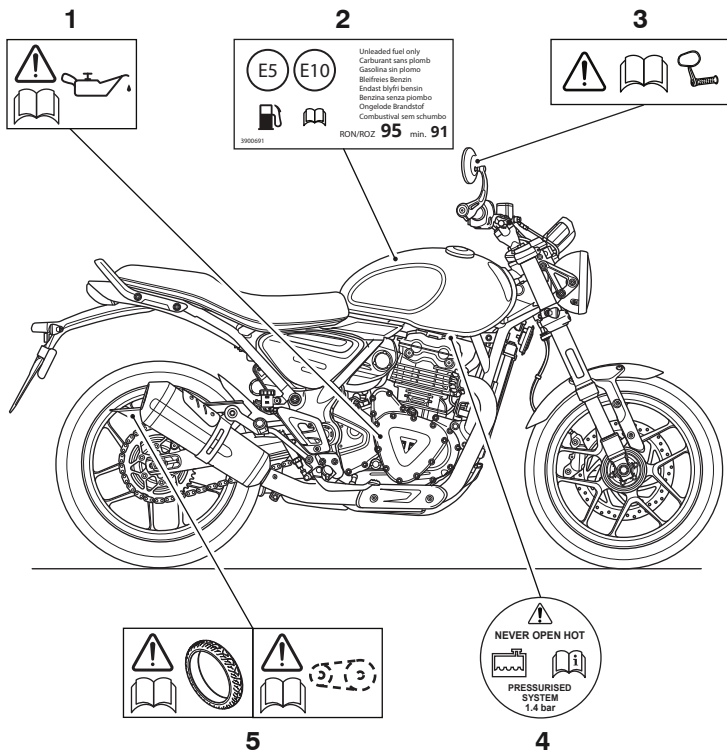

1. Engine Oil (page 89)
2. E5 and E10 Fuel (if equipped) (page 48)
3. Bar End Mirrors (if equipped) (page 113)
4. Coolant - Radiator Filler Cap (page 95)
5. Tires (page 121) and Drive Chain (page 101)

Speed 400

Left Hand Side

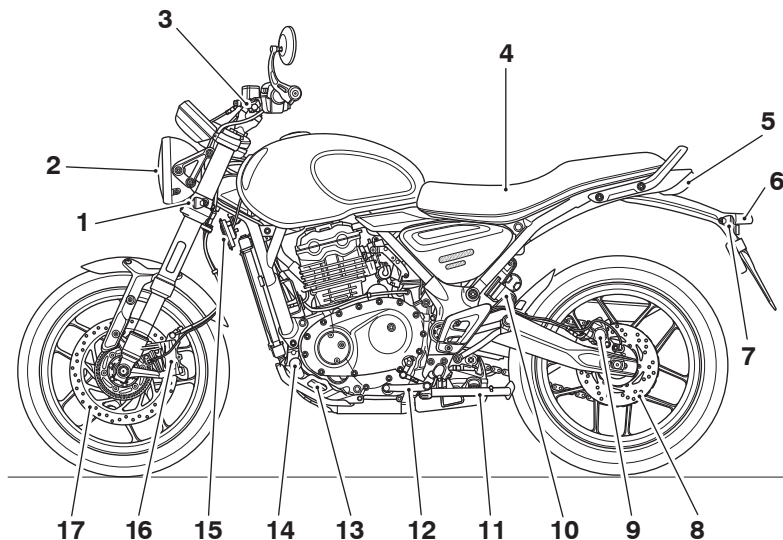

- 1. Front turn signal
- 2. Headlight
- 3. Clutch lever
- 4. Battery (under seat)
- 5. Rear/brake light
- 6. License plate light
- 7. Rear turn signal
- 8. Rear brake disc
- 9. Rear brake caliper

- 10. Rear suspension unit
- 11. Side stand
- 12. Gear shift pedal
- 13. Coolant expansion tank
- 14. Coolant expansion tank cap
- 15. Horn
- 16. Front brake caliper
- 17. Front brake disc

Right Hand Side

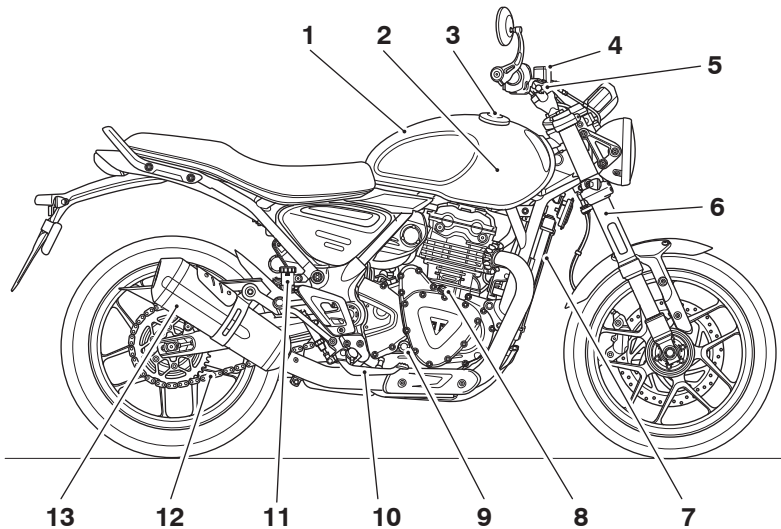

- | | |
|---|--------------------------------|
| 1. Fuel tank | 8. Oil filler plug |
| 2. Coolant pressure cap (under fuel tank) | 9. Oil level sight glass |
| 3. Fuel filler cap | 10. Rear brake pedal |
| 4. Front brake fluid reservoir | 11. Rear brake fluid reservoir |
| 5. Front brake lever | 12. Drive chain |
| 6. Front fork | 13. Muffler |
| 7. Radiator | |

Scrambler 400 X

Left Hand Side

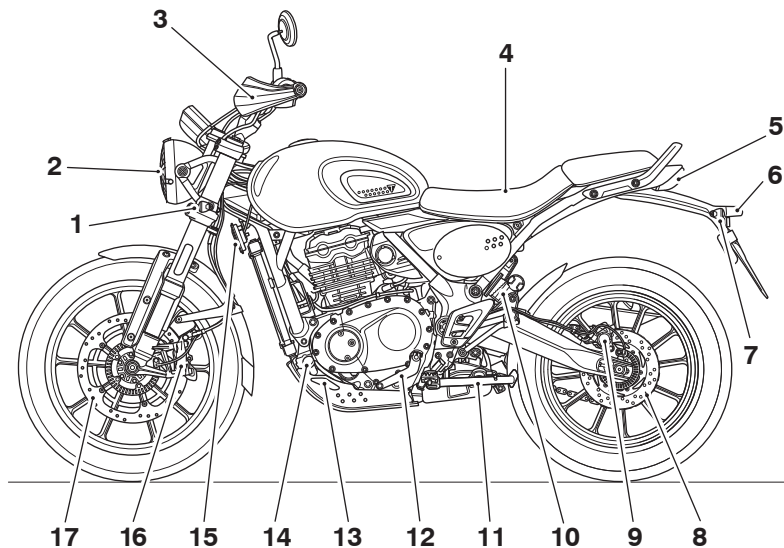

1. Front turn signal
2. Headlight
3. Clutch lever (behind handguard)
4. Battery (under seat)
5. Rear/brake light
6. License plate light
7. Rear turn signal
8. Rear brake disc
9. Rear brake caliper

10. Rear suspension unit
11. Side stand
12. Gear shift pedal
13. Coolant expansion tank
14. Coolant expansion tank cap
15. Horn
16. Front brake caliper
17. Front brake disc

Right Hand Side

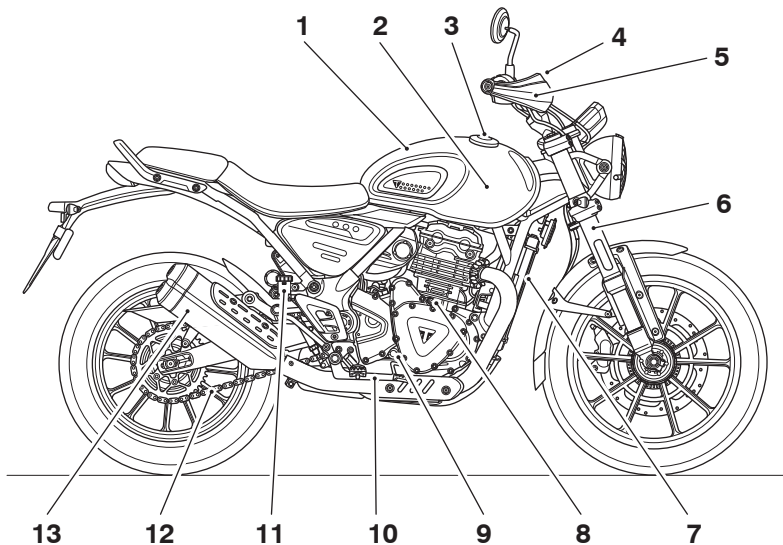

- | | |
|---|--------------------------------|
| 1. Fuel tank | 7. Radiator |
| 2. Coolant pressure cap (under fuel tank) | 8. Oil filler plug |
| 3. Fuel filler cap | 9. Oil level sight glass |
| 4. Front brake fluid reservoir (behind handguard) | 10. Rear brake pedal |
| 5. Front brake lever (behind handguard) | 11. Rear brake fluid reservoir |
| 6. Front fork | 12. Drive chain |
| | 13. Muffler |

Rider View Parts Identification

Speed 400 shown

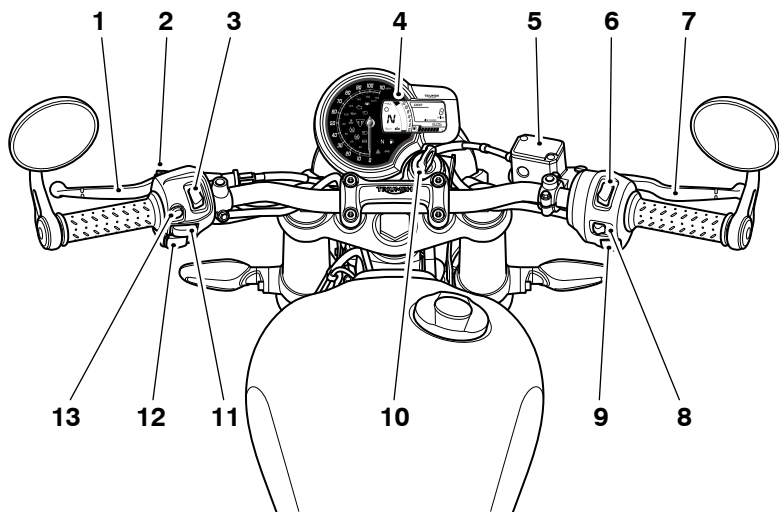

- | | |
|---|--------------------------------|
| 1. Clutch lever | 7. Front brake lever |
| 2. High beam switch | 8. Hazard warning light switch |
| 3. Daytime Running Lights (DRL) switch
(if equipped) | 9. START button |
| 4. Instruments | 10. Ignition switch |
| 5. Front brake fluid reservoir | 11. Turn signal switch |
| 6. Engine run/stop switch | 12. Horn button |
| | 13. SCROLL/SELECT button |

Vehicle Identification Number (VIN)

The vehicle identification number is stamped into the steering head area of the frame, and is visible from the right hand side of the motorcycle. The VIN is also displayed on a label attached to the left hand side of the frame, directly behind the top of the radiator.

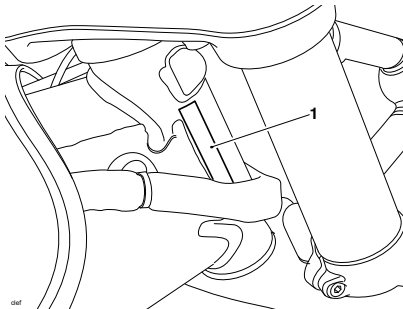

1. VIN stamp (Scrambler 400 X shown)

Record the VIN in the space provided in the Motorcycle Service Handbook.

Engine Serial Number

The engine serial number is stamped on the lower engine crankcase, and is visible from the right hand side of the motorcycle, below the engine oil sight glass.

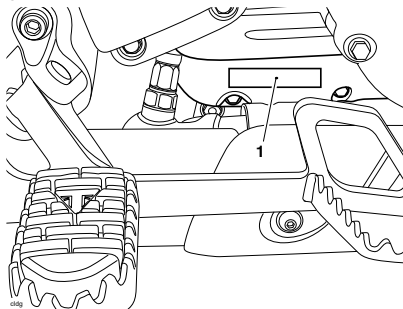

1. Engine serial number (Scrambler 400 X shown)

Record the engine serial number in the space provided in the Motorcycle Service Handbook.

This page intentionally left blank

Table of Contents

Instruments Display - Speed 400 and Scrambler 400 X	26
Warning Lights	27
Engine Management System Malfunction Indicator Light (MIL)	27
Low Oil Pressure Warning Light	27
High Coolant Temperature Warning Light	28
Engine Immobilizer Indicator Light	28
Anti-lock Braking System (ABS) Warning Light	28
Traction Control (TC) Indicator Light	29
Traction Control (TC) Disabled Warning Light	30
Turn signal Light	30
Hazard Warning Lights	30
High Beam Indicator Light	30
Daytime Running Lights (DRL) Indicator Light (if equipped)	30
Neutral Indicator Light	31
Low Fuel Indicator Light	31
Speedometer	31
Multi-function Display	32
Odometer	32
Tachometer	32
Fuel Gage	32
Gear Position	33
Side Stand	33
Clock	33
Service	34
Heated Grips (if equipped)	34
Trip Meter	35
Current Fuel Consumption	36
Average Fuel Consumption	36
Range To Empty	36
Triumph Traction Control (TTC) Setting	37
Off-road Mode	37
Set	37

Instruments Display - Speed 400 and Scrambler 400 X

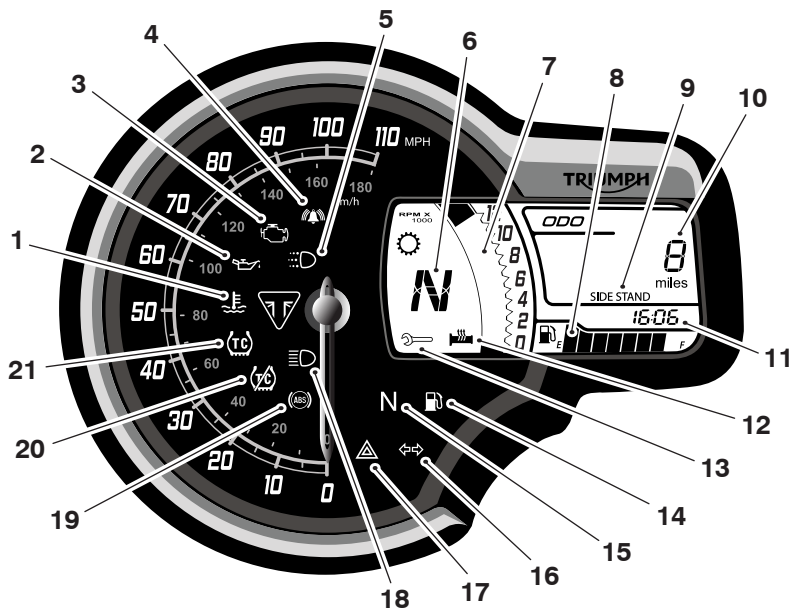

- | | |
|---|--|
| 1. High coolant temperature warning light | 12. Heated grips symbol (if equipped) |
| 2. Low oil pressure warning light | 13. Service symbol or general warning symbol |
| 3. Engine management Malfunction Indicator Light (MIL) | 14. Low fuel indicator light |
| 4. Engine immobilizer indicator light | 15. Neutral indicator light |
| 5. Daytime Running Lights (DRL) indicator light (if equipped) | 16. Turn signal light |
| 6. Gear position indicator | 17. Hazard warning light |
| 7. Tachometer | 18. High beam indicator light |
| 8. Fuel gage | 19. Anti-lock Brake System (ABS) warning light |
| 9. Side stand indicator | 20. Traction Control (TC) disabled warning light |
| 10. Multi-function display (Odometer shown) | 21. Traction Control (TC) indicator light |
| 11. Clock | |

Warning Lights

NOTICE

If a red warning light is shown then the motorcycle must be stopped immediately. Read any warning messages and rectify the issue.

If an amber warning light is shown then the motorcycle does not need to be stopped immediately. Read any warning messages and rectify the issue.

When the ignition is switched on, the instrument warning lights will illuminate for 1.5 seconds and will then go off (except those which remain on until the engine starts, as described in the following pages).

Engine Management System Malfunction Indicator Light (MIL)



The Malfunction Indicator Light (MIL) for the engine management system illuminates when the ignition is switched ON (to indicate that it is working) but should not become illuminated when the engine is running.

If the engine is running and there is a fault with the engine management system the MIL will be illuminated and the general warning symbol will flash. In such circumstances, the engine management system may switch to 'limp-home' mode so that the journey may be completed, if the fault is not so severe that the engine will not run.

WARNING

Reduce speed and do not continue to ride for longer than is necessary with the Malfunction Indicator Light (MIL) illuminated. The fault may affect engine performance, exhaust emissions and fuel consumption.

The fault must be checked and rectified by a competent person with the specialist knowledge and technical understanding of motorcycles, such as an authorized Triumph dealer.

Reduced engine performance could cause a dangerous riding condition, leading to loss of motorcycle control which could result in serious injury or death.

If the MIL flashes when the ignition is switched ON contact an authorized Triumph dealer as soon as possible to have the situation rectified. In these circumstances the engine will not start.

Low Oil Pressure Warning Light



With the engine running, if the engine oil pressure becomes dangerously low, the low oil pressure warning light will illuminate. The low oil pressure warning light will also illuminate if the ignition is switched ON without running the engine.

NOTICE

If the engine oil pressure is too low, the low oil pressure warning light will illuminate.

If the low oil pressure indicator remains on, stop the engine immediately and investigate the situation.

Running the engine with low oil pressure will cause severe engine damage.

High Coolant Temperature Warning Light

With the engine running, if the engine coolant temperature becomes dangerously high, the high coolant temperature warning light will illuminate.

NOTICE

Stop the engine immediately if the high coolant temperature warning light illuminates.

Do not restart the engine until the fault has been rectified.

Severe engine damage will result from running the engine when the high coolant temperature warning light is illuminated.

Engine Immobilizer Indicator Light

This motorcycle is equipped with an engine immobilizer which is activated when the ignition switch is turned to the OFF position.

When the ignition switch is turned to the OFF position, the engine immobilizer light will flash on and off for 24 hours to show that the engine immobilizer is on. When the ignition switch is turned to the ON position the engine immobilizer and the indicator light will be off.

If the indicator light remains on it indicates that the engine immobilizer has a malfunction that requires investigation. The fault must be checked and rectified by a competent person with the specialist knowledge and technical understanding of motorcycles, such as an authorized Triumph dealer.

Anti-lock Braking System (ABS) Warning Light**WARNING**

If the Anti-lock Brake System (ABS) is not functioning, the brake system will continue to function as a non-ABS equipped brake system. Do not continue to ride for longer than is necessary with the ABS warning light illuminated.

The fault must be checked and rectified by a competent person with the specialist knowledge and technical understanding of motorcycles, such as an authorized Triumph dealer.

Braking too hard will cause the wheels to lock, leading to loss of motorcycle control which could result in serious injury or death.

NOTICE

Traction control will not function if there is a malfunction with the ABS. The warning lights for the ABS, traction control and the MIL will be illuminated.



When the ignition switch is turned to the ON position, it is normal that the ABS warning light will be illuminated. The light will remain on until the motorcycle first reaches a speed exceeding 6 mph (10 km/h) when it will go off.

The warning light will not illuminate again until the engine is restarted unless there is a fault, or the ABS is disabled by the rider (off-road mode for Scrambler 400 X only).

Scrambler 400 X only: If the ABS is disabled by the rider (off-road mode), the warning light will remain illuminated until the ABS is enabled again.

If there is a fault with the ABS system the warning light will be illuminated and the general warning symbol will flash.

Traction Control (TC) Indicator Light

The Traction Control (TC) indicator light is used to indicate that the traction control system is active and is working to limit rear wheel slip during periods of hard acceleration or under wet or slippery road conditions. Traction control will not function if there is a malfunction with the ABS. The warning lights for the ABS, traction control and the MIL will be illuminated.

WARNING

If the traction control is not functioning, care must be taken when accelerating and cornering on wet/slippery road surfaces to avoid rear wheel spin. Do not continue to ride for longer than is necessary with the engine management system Malfunction Indicator Light (MIL) and traction control warning lights illuminated.

The fault must be checked and rectified by a competent person with the specialist knowledge and technical understanding of motorcycles, such as an authorized Triumph dealer.

Hard acceleration and cornering may cause the rear wheel to spin, leading to loss of motorcycle control which could result in serious injury or death.

If traction control is switched on:

- ▼ Under normal riding conditions the TC indicator light will remain off.
- ▼ The TC indicator light will flash rapidly when the traction control system is working to limit rear wheel slip during periods of hard acceleration or under wet or slippery road conditions.

If traction control is switched off:

- ▼ The TC indicator light will not illuminate. Instead the TC disabled warning light will be illuminated.

INSTRUMENTS

Traction Control (TC) Disabled Warning Light



The Traction Control (TC) disabled warning light should not illuminate unless traction control is switched off or there is a malfunction.

If the warning light becomes illuminated while riding, it indicates that the traction control system has a malfunction that requires investigation. The fault must be checked and rectified by a competent person with the specialist knowledge and technical understanding of motorcycles, such as an authorized Triumph dealer.

Turn signal Light



When the turn signal switch is turned to the left or right, the turn signal light will flash on and off at the same speed as

the turn signals.

Hazard Warning Lights



When the hazard warning switch is turned on, the turn signal warning lights will flash on and off at the same speed as the turn signals.

High Beam Indicator Light



When the ignition is switched ON and the high beam is selected, the high beam indicator light will illuminate.

Daytime Running Lights (DRL) Indicator Light (if equipped)



When the ignition is switched ON and the daytime running lights switch is set to Daytime Running Lights, the daytime running lights indicator light will illuminate. During daylight hours, the Daytime Running Lights (DRL) improve the visibility of the motorcycle to other road users. Dipped beam headlights must be used in any other conditions unless the road conditions allow for high beam headlights to be used.

When the dipped beam headlight is switched on, the daytime running lights indicator light will be off.

The daytime running lights and dipped beam headlights are operated manually using a switch on the left hand switch housing.

WARNING

Do not ride for longer than necessary in poor ambient light conditions with the Daytime Running Lights (DRL) in use.

Riding with the Daytime Running Lights when dark, in tunnels or where poor ambient light is apparent may reduce the riders vision or blind other road users.

Blinding other road users or reduced vision in low ambient light levels may lead to loss of motorcycle control which could result in serious injury or death.

Neutral Indicator Light

N The neutral indicator light indicates when the transmission is in neutral (no gear selected). The indicator light will illuminate when the transmission is in neutral with the ignition switch in the ON position.

Low Fuel Indicator Light

 The low fuel indicator light will illuminate when there is approximately 0.8 gallon (3 liters) of fuel remaining in the tank.

Speedometer

The speedometer indicates the road speed of the motorcycle.

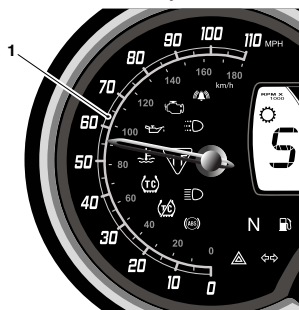

1. Speedometer

Condensation

In certain conditions, condensation may occur inside the speedometer.

Condensation may happen while it is raining or after washing the motorcycle.

Condensation inside the speedometer will gradually disappear while riding the motorcycle.

Time for evaporation will vary depending on the humidity of the ambient air.

NOTICE

If condensation inside the speedometer does not clear, we recommend that the speedometer is inspected by a competent person with the specialist knowledge and technical understanding of motorcycles, such as an authorized Triumph dealer.

Multi-function Display

Odometer

The odometer shows the total distance that the motorcycle has traveled.

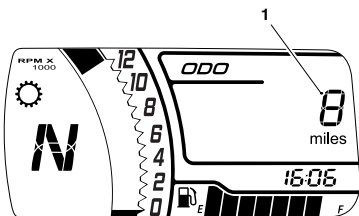

1. Odometer

Tachometer

NOTICE

Never allow engine speed to exceed the maximum engine speed as severe engine damage may result.

The tachometer shows the engine speed in revolutions per minute - rpm (r/min).

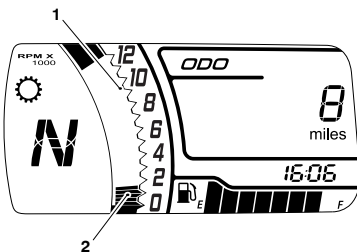

1. Maximum engine speed
2. Engine speed (rpm)

The maximum engine speed is 9,500 rpm.

Engine speeds above the maximum engine speed are above the range for best engine performance and may result in engine damage.

For more information on the tachometer during running-in, see page 63.

Fuel Gage

The fuel gage indicates the amount of fuel in the tank.

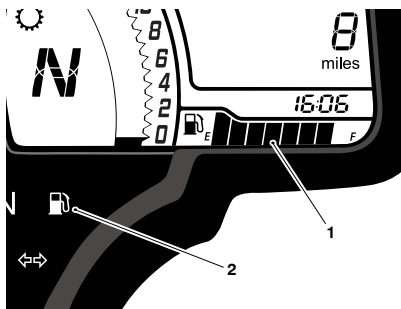

1. Fuel gage
2. Low fuel indicator light

With the ignition switched on, the number of bars shown in the display indicates the level of fuel.

When the fuel tank is full all eight bars are displayed and when empty, no bars are displayed. Other gage markings indicate intermediate fuel levels between full and empty.

When there is approximately 0.8 gallon (3 liters) of fuel remaining in the tank, the low fuel warning light will illuminate.

NOTICE

After refueling, the fuel gage information will be updated only while riding the motorcycle. Depending on the riding style, updating could take up to one minute.

Gear Position

The gear position display indicates which gear (1-6) has been engaged. When the transmission is in neutral (no gear selected), the display screen will show 'N'.

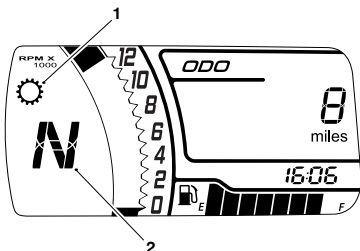

1. Gear position symbol
2. Gear position display (neutral shown)

Side Stand

The side stand indicator shows when the side stand is down. The indicator will not be shown when the side stand is up.

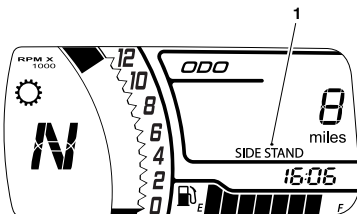

1. Side stand indicator

For more information on the side stand, see page 53.

Clock

The clock displays the time in the 24 hour format.

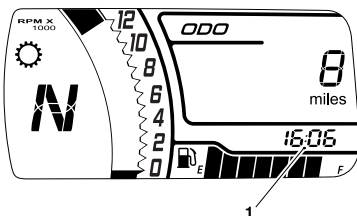

1. Clock

INSTRUMENTS

Service

The service interval is set to a distance and/or time period.

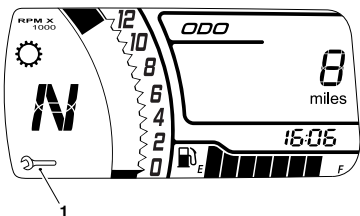

1. Service symbol or general warning symbol

When the ignition is switched on and the distance to the next service is 62 miles (100 km) or less, the display will show the service symbol for five seconds after the ignition is switched on. When the remaining distance is 0 miles (0 km) or overdue, the service symbol will remain on until the service has been carried out and the system has been reset.

We recommend the service interval is reset by a competent person with the specialist knowledge and technical understanding of motorcycles, such as an authorized Triumph dealer.

Heated Grips (if equipped)

To operate the heated grips:

- ▼ Push and release the heated grips button to show the current heated grips status on the display for three seconds.

- ▼ Push and release the heated grips button within three seconds of the first push to engage the low setting - 'LO' will be shown on the display.

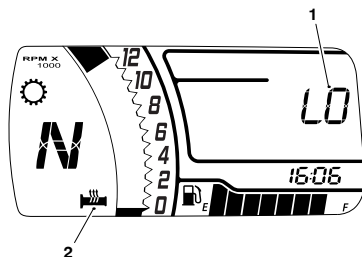

1. Heated grips display (low heat setting shown)
2. Heated grips symbol

- ▼ Push and release the heated grips button within three seconds of the second push to engage the high setting - 'HI' will be shown on the display.
- ▼ Push and release the heated grips button within three seconds of the third push to turn the heated grips off - 'OFF' will be shown on the display.

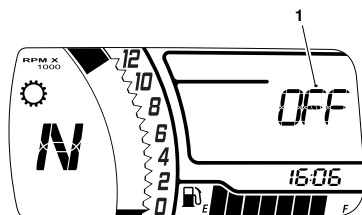

1. Heated grips off display

For more information on the heated grips, see page 47.

Trip Meter

⚠ WARNING

Do not attempt to switch between the odometer and trip meter display modes or reset the trip meter while the motorcycle is in motion.

Stop the motorcycle to switch between the odometer and trip meter display modes or reset the trip meter.

Failure to follow the advice above may lead to loss of motorcycle control which could result in serious injury or death.

There are two trip meters. Either trip meter shows the distance that the motorcycle has traveled since the meter on display was last reset to zero.

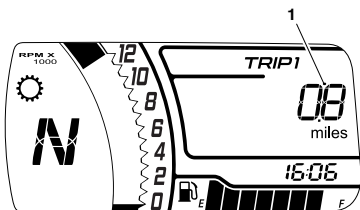

1. Trip meter display (TRIP 1 shown)

To switch between trip meters, push and release the SCROLL/SELECT button, located on the left handlebar switch, until the required trip meter is shown.

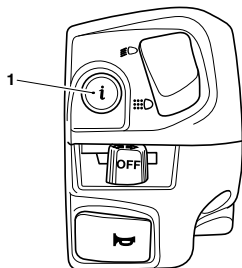

68P_1

1. SCROLL/SELECT button

Scrambler 400 X Only

The trip meters are not accessible when in off-road mode. The trip meter data continues to be collected when riding in off-road mode. The updated trip meter data is shown in the trip meters after switching the off-road mode off.

Trip Meter Reset

To reset either of the trip meters:

- ▼ Select the trip meter to be zeroed.
- ▼ Push and hold the SCROLL/SELECT button for one second. After more than one second, the trip meter on display will reset to zero.

INSTRUMENTS

Current Fuel Consumption

This is an indication of the fuel consumption at an instant in time. If the motorcycle is stationary, 0.0 will be shown in the display area.

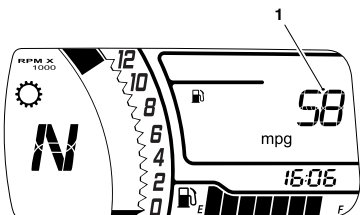

1. Current fuel consumption

The instruments will display the current fuel consumption in the following units:

- ▼ km/l
- ▼ l/100 km
- ▼ mpg.

Average Fuel Consumption

This is an indication of the average fuel consumption. After being reset the display will show dashes until one mile/km has been covered.

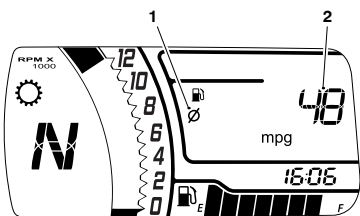

1. Average symbol
2. Average fuel consumption

The instruments will display the average fuel consumption in the following units:

- ▼ km/l
- ▼ l/100 km
- ▼ mpg.

NOTICE

After refueling, the average fuel consumption information will be updated only while riding the motorcycle. Depending on the riding style, updating could take up to one minute.

Average Fuel Consumption Reset

To reset the average fuel consumption:

- ▼ When the average fuel consumption menu is displayed, push and hold the SCROLL/SELECT button for one second. After more than one second, the average fuel consumption will reset to zero.

Range To Empty

This is an indication of the predicted distance that can be traveled on the remaining fuel in the tank.

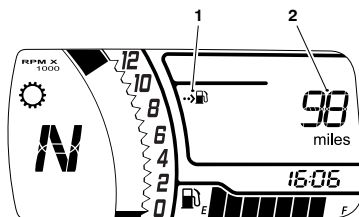

1. Range to empty indicator
2. Estimated distance remaining

NOTICE

After refueling, the range to empty information will be updated only while riding the motorcycle. Depending on the riding style, updating could take up to one minute.

Triumph Traction Control (TTC) Setting

The Triumph Traction Control (TTC) system can be temporarily disabled. The TTC system cannot be permanently disabled, it will be automatically enabled when the ignition is turned off and then on again.

To enable or disable the TTC system:

- ▼ Push and release the SCROLL/SELECT button until 'ttc On' is displayed.

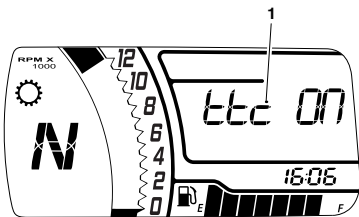

1. Traction control setting display

- ▼ Push and hold the SCROLL/SELECT button for one second to select the TTC menu.
- ▼ Push and release the SCROLL/SELECT button to turn TTC on or off.

Off-road Mode

Scrambler 400 X Only

To enable or disable the off-road mode:

- ▼ Push and release the SCROLL/SELECT button until 'OFF rd' is displayed.

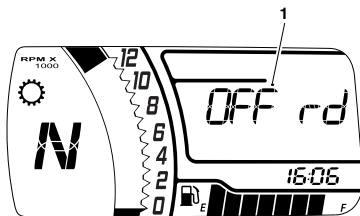

1. Off-road mode display

- ▼ Push and hold the SCROLL/SELECT button for one second to select the off-road menu.
- ▼ Push and release the SCROLL/SELECT button to turn off-road on or off.

Mode	Description
Off-road	Anti-lock Braking System (ABS) is off. Traction Control (TC) is off. All Multi-function Display menus are not shown. Trip meter data continues to be collected when riding in this mode. Off-road mode can only be selected when the motorcycle is stationary.

Set

The set menu allows configuration of the clock and units.

INSTRUMENTS

To access the set menu:

- ▼ Push and release the **SCROLL/SELECT** button until the set menu is displayed.

Clock

⚠ WARNING

Do not attempt to set the clock while the motorcycle is in motion.

Stop the motorcycle to set the clock.

Failure to follow the advice above may lead to loss of motorcycle control which could result in serious injury or death.

The clock menu allows the adjustment of the clock to be set to the local time.

To set the clock:

- ▼ From the set menu, push and hold the **SCROLL/SELECT** button for one second to select **CLOCK**.

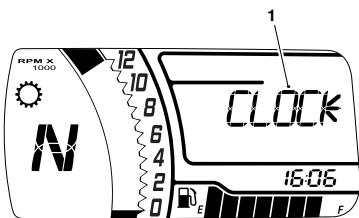

1. Clock menu

- ▼ From **CLOCK**, push and hold the **SCROLL/SELECT** button for one second and the clock's hour display will start to flash. Release the **SCROLL/SELECT** button.

To set the hour display:

- ▼ Make sure the hour display is still flashing then push and release the **SCROLL/SELECT** button to change the setting. Each individual push of the button will change the setting by one digit.
- ▼ When the correct hour display is shown, push and hold the **SCROLL/SELECT** button for one second. The hours display is set and the minutes display will begin to flash. The minutes display is adjusted in the same way as the hour display.
- ▼ Once both hours and minutes are correctly set, the menu will automatically revert back to the previous screen after four seconds.

Units

⚠ WARNING

Do not attempt to set the units while the motorcycle is in motion.

Stop the motorcycle to set the units.

Failure to follow the advice above may lead to loss of motorcycle control which could result in serious injury or death.

The units menu allows the selection of a preferred unit of measurement.

To set the units:

- ▼ From the set menu, push and hold the **SCROLL/SELECT** button for one second to select **CLOCK**.

- ▼ From CLOCK, push and release the SCROLL/SELECT button until UNITS is displayed.

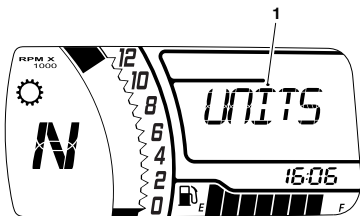

The options available are:

Distance/Economy:

- ▼ miles and mpg (UK)
- ▼ miles and mpg (US)
- ▼ km and l/100 km
- ▼ km and km/l.

1. Units menu

- ▼ Push and hold the SCROLL/SELECT button for one second to select UNITS.
- ▼ From UNITS, push and release the SCROLL/SELECT button to select the required option.

This page intentionally left blank

Table of Contents

Controls	42
Throttle Control	42
Ignition Switch/Steering Lock	42
Ignition Key	43
Engine Immobilizer	44
Right Handlebar Switches	45
Left Handlebar Switches	46
Fuel	48
Refueling	49
Traction Control (TC)	51
Traction Control Settings	51
To Disable the Traction Control	52
Side Stand	53
Side Panels	54
Side Panels - Removal	54
Side Panel - Installation	55
Seats	56
Seat Care	56
Seat Lock	56
Seat - Removal	57
Seat - Installation	58
Owner's Handbook and Tool Kit	61
Universal Serial Bus (USB) Socket	61
Breaking-In	63
Daily Safety Checks	64

Controls

Throttle Control

All models have an electronic throttle twist grip to open and close the throttle via the engine control unit. There are no direct-acting cables in the system.

The throttle grip has a resistive feel to it as it is rolled rearwards to open the throttle. When the grip is released it will return to the throttle closed position by its internal return spring and the throttle will close.

There are no user adjustments for the throttle control.

If there is a malfunction with the throttle control the Malfunction Indicator Light (MIL) becomes illuminated and one of the following engine conditions may occur:

- ▼ MIL illuminated, restricted engine RPM and throttle movement
- ▼ MIL illuminated, limp-home mode with the engine at a fast idle condition only
- ▼ MIL illuminated, engine will not start.

For all of the conditions mentioned, the fault must be checked and rectified by a competent person with the specialist knowledge and technical understanding of motorcycles, such as an authorized Triumph dealer.

WARNING

Reduce speed and do not continue to ride for longer than is necessary with the Malfunction Indicator Light (MIL) illuminated. The fault may affect engine performance, exhaust emissions and fuel consumption.

The fault must be checked and rectified by a competent person with the specialist knowledge and technical understanding of motorcycles, such as an authorized Triumph dealer.

Reduced engine performance could cause a dangerous riding condition, leading to loss of motorcycle control which could result in serious injury or death.

Ignition Switch/Steering Lock

WARNING

For reasons of security and safety, always turn the ignition to the LOCK position and remove the key when leaving the motorcycle unattended.

Any unauthorized use of the motorcycle may lead to loss of motorcycle control which could result in serious injury or death.

WARNING

With the key in the LOCK position, the steering will become locked.

Never turn the key to the LOCK position while the motorcycle is moving as this will cause the steering to lock.

Locked steering will lead to loss of motorcycle control which could result in serious injury or death.

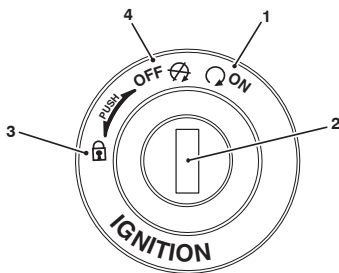

1. ON position
2. Ignition switch/Steering lock
3. LOCK position
4. OFF position

Switch Operation

This is a three position, key operated switch. The key can be removed from the switch only when it is in the OFF or LOCK position.

TO LOCK: Turn the steering fully to the left, turn the key to the OFF position, push and fully release the key, then rotate it to the LOCK position.

Ignition Key**WARNING**

Additional keys, key rings/chains or items attached to the ignition key may interfere with the steering.

Remove all additional keys, key rings/chains and items from the ignition key before riding the motorcycle.

Failure to follow the advice above may lead to loss of motorcycle control which could result in serious injury or death.

NOTICE

Additional keys, key rings/chains or items attached to the ignition key may cause damage to the motorcycle's painted or polished components.

Remove all additional keys, key rings/chains and items from the ignition key before riding the motorcycle.

NOTICE

Do not store the spare key with the motorcycle as this will reduce all aspects of security.

GENERAL INFORMATION

NOTICE

Key functions may be disrupted by electronic devices, environmental electrical noise sources and metal objects.

Avoid storing and using the key near the following:

- Electrical service masts, radio masts and power distribution infrastructure
- Garage door opener devices
- Radio-Frequency Identification (RFID) access cards or fobs
- Metal, metallic card holders and aluminum items
- Other vehicle electronic keys
- In panniers or top boxes
- Wireless communication devices such as mobile phones, tablets, laptops, portable game systems, audio players, radios and chargers.

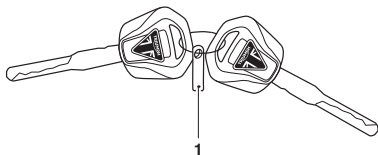

1. Key number tag

In addition to operating the ignition switch/steering lock, the ignition key is required to operate the seat lock and fuel tank cap.

When the motorcycle is delivered from the factory, two ignition keys are supplied together with a small tag bearing the key number. Make a note of the key number and store the spare key and key number tag in a safe place away from the motorcycle.

There is a transponder within the ignition keys to turn off the engine immobilizer. To make sure the immobilizer functions correctly, always have only one of the ignition keys near the ignition switch. Having two ignition keys near the switch may interrupt the signal between the transponder and the engine immobilizer. In this situation the engine immobilizer will remain active until one of the ignition keys is removed. Replacement keys must be 'paired' with the motorcycle's immobilizer.

Engine Immobilizer

The ignition switch housing acts as the antenna for the engine immobilizer.

When the ignition switch is turned to the OFF position and the ignition key is removed, the engine immobilizer is on (see page 28). The engine immobilizer is turned off when the ignition key is in the ignition switch and it is turned to the ON position.

Right Handlebar Switches

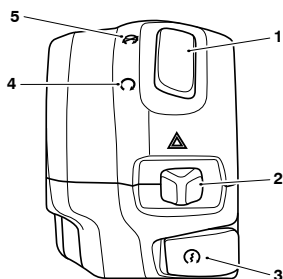

009

1. Engine run/stop switch
2. Hazard warning light switch
3. START button
4. RUN position
5. STOP position

STOP Position

The STOP position is for emergency use. If an emergency arises which requires the engine to be stopped, move the engine run/stop switch to the STOP position.

NOTICE

Although the engine stop switch stops the engine, it does not turn off all the electrical circuits and may cause difficulty in restarting the engine due to a discharged battery. Ordinarily, only the ignition switch should be used to stop the engine.

Do not leave the ignition switch in the ON position unless the engine is running as this may cause damage to electrical components and will discharge the battery.

RUN Position

In addition to the ignition switch being turned to the ON position, the engine run/stop switch must be in the RUN position for the motorcycle to operate.

START Button

The START button operates the electric starter.

NOTICE

The starter will not operate if the side stand is down and a gear is engaged.

Hazard Warning Light Switch

To turn the hazard warning lights on, push the hazard warning light switch to the left.

The ignition must be switched ON for the hazard warning lights to function.

The hazard warning lights will remain on if the ignition is switched OFF, until the hazard warning light switch is pushed to the right.

Left Handlebar Switches

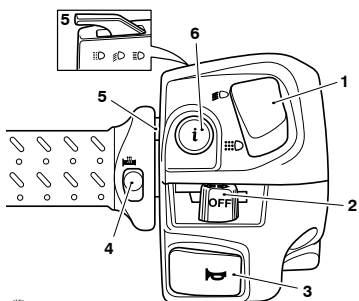

1. Dipped beam/Daytime Running Lights (DRL) switch (if equipped)
2. Turn signal switch
3. Horn button
4. Heated grips button (if equipped)
5. High beam switch
6. SCROLL/SELECT button

SCROLL/SELECT Button

The SCROLL/SELECT button is used to operate the following functions of the instruments:

- ▼ Odometer (see page 32)
- ▼ Trip meters and reset (see page 35)
- ▼ Average fuel consumption and reset (see page 36)
- ▼ Traction control (see page 37)
- ▼ Off-road mode (see page 37)
- ▼ Clock (see page 37)
- ▼ Units (see page 37).

Dipped Beam/Daytime Running Lights (DRL) Switch (if equipped)

NOTICE

Daytime running lights are manually operated. They are not automatic.

The daytime running lights or dipped beam can be selected with the Daytime Running Lights (DRL) switch.

To select daytime running lights, push the dipped beam/DRL switch downwards.

To select dipped beam, push the dipped beam/DRL switch upwards.

When the daytime running lights are turned on, the daytime running lights indicator light will illuminate in the instrument panel.

Turn Signal Switch

When the turn signal switch is pushed to the left or right, the corresponding turn signals will flash on and off.

The turn signals can be canceled manually. To manually turn off the turn signals, push and release the turn signal switch in the central position.

Horn Button

When the horn button is pushed, with the ignition switch turned on, the horn will sound.

High Beam Switch

This is a three position switch.

When the high beam switch is pushed forward the high beam will be switched on. Push the switch back to the central position to turn the high beam off. The high beam will only come on when the engine is running or the motorcycle is moving at greater than 3 mph (5 km/h).

Push and release the switch rearwards to engage a flash function. Releasing will return the switch to the central position and turn the high beam off.

If daytime running lights are installed on the motorcycle, the high beam switch has additional functionality.

If the DRL switch is in the daytime running lights position, push the high beam switch forward to turn the high beam on. When the high beam switch is returned to the central position the DRL will be activated again.

A lighting on/off switch is not installed on this model. The position light, tail light and license plate light all function automatically when the ignition is on.

The headlight and DRL will function when the engine is on.

Heated Grips Button (if equipped)

The heated grips will only heat when the engine is running.

When the heated grips are turned on, the heated grips symbol will appear and the selected heat level will be shown in the display. When the heated grips are turned off, the heated grips symbol is no longer shown, see page 34.



1. Heated grips symbol

For maximum benefit in cold conditions, from the OFF position and after a push to show the current heated grips status, push the switch twice for the high heat setting initially and then reduce the heat level by pushing the switch twice again for a low heat setting when the grips have warmed up.

Low Power Voltage Cut Off

If a low voltage is detected, the heated grips will power off. The heated grips will not function again until the voltage rises to a safe level.

The heated grips will not power back on automatically even if the voltage rises to the safe level. The user must manually push the button again to activate the heated grips.

Fuel

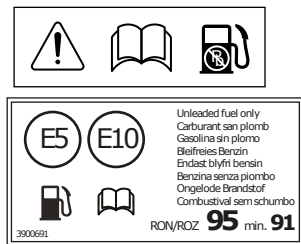

Fuel Grade

Triumph motorcycles are designed to run on unleaded gasoline with a CLC or AKI octane rating $(R+M)/2$ of 87 or higher (91 RON). Federal regulations require that pumps delivering unleaded gasoline are marked 'UNLEADED' and that the Cost of Living Council (CLC) or Anti-Knock Index (AKI) octane rating is also displayed. These ratings are an average of the Research Octane Number (RON) and the Motor Octane Number (MON).

Ethanol

In Europe, Triumph motorcycles are compatible with Ethanol E5 and E10 (5% and 10% Ethanol) unleaded fuel.

In all other markets Ethanol up to E25 (25% Ethanol) may be used.

Engine Calibration

In certain circumstances engine calibration may be required. This should be completed by a competent person with the specialist knowledge and technical understanding of motorcycles, such as an authorized Triumph dealer.

NOTICE

The motorcycle can be permanently damaged if it is allowed to operate with the incorrect grade of fuel or incorrect engine calibration.

Always make sure the fuel used is of the correct grade and quality.

Damage caused by using the incorrect fuel or engine calibration is not considered a manufacturing defect and will not be covered under warranty.

NOTICE

The exhaust system for this motorcycle is equipped with a catalytic converter to help reduce exhaust emission levels.

Use of leaded fuel will damage the catalytic converter. In addition, the catalytic converter can be permanently damaged if the motorcycle is allowed to run out of fuel or if the fuel level is allowed to get very low.

Always make sure you have adequate fuel for your trip.

NOTICE

The use of leaded fuel is illegal in some countries, states or territories.

NOTICE

If 'knocking' or 'pinging' occurs at a steady engine speed under normal load, use a different brand of gasoline or gasoline which has a higher octane rating.

Oxygenated Gasoline

To help in meeting clean air standards, some areas of the U.S. use oxygenated gasoline to help reduce harmful emissions. These gasolines are a blend of conventional gasoline and another compound such as alcohol. This Triumph motorcycle will give its best performance when using unleaded gasoline. However, the following should be used as a guide if you use any oxygenated fuels.

Ethanol

Ethanol fuel is a mixture of 10% Ethanol and 90% gasoline and is often described under the names 'gasohol', 'Ethanol enhanced', or 'contains Ethanol'. This fuel may be used in your Triumph motorcycle.

MTBE (Methyl Tertiary Butyl Ether)

The use of gasolines containing up to 15% MTBE (Methyl Tertiary Butyl Ether) is permitted in this Triumph motorcycle.

Methanol

Fuels containing methanol should not be used as damage to components in the fuel system can be caused by contact with methanol.

NOTICE

Because of the generally higher volatility of oxygenated fuels, starting, engine response and fuel consumption may be adversely affected by their use. Should any of these difficulties be experienced, run the motorcycle on normal unleaded gasoline.

Refueling

WARNING

To help reduce hazards associated with refueling, always observe the following fuel safety instructions:

- Gasoline (fuel) is highly flammable and can be explosive under certain conditions. When refueling, turn the ignition switch to the OFF position.
- Do not smoke.
- Do not use a mobile telephone.
- Make sure the refueling area is well ventilated and free from any source of flame or sparks. This includes any appliance with a pilot light.
- Pay full attention and remain alert while refueling.
- Never fill the tank until the fuel level rises into the filler neck. Heat from sunlight or other sources may cause the fuel to expand and overflow creating a fire hazard.
- After refueling always check that the fuel filler cap is correctly closed.
- Because gas (fuel) is highly flammable, any fuel leak or spillage, or any failure to observe the safety advice given above will lead to a fire hazard, which could cause damage to property, serious injury or death.

NOTICE

Avoid filling the tank in rainy or dusty conditions where airborne material can contaminate the fuel.

Contaminated fuel may cause damage to fuel system components.

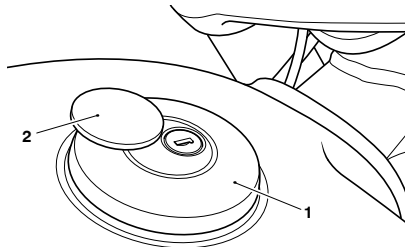
Fuel Tank Cap

1. Fuel tank cap
2. Cap cover

To open the fuel tank cap:

- ▼ Slide the cap cover to the side to show the key lock.
- ▼ Insert the key into the lock and turn the key clockwise.
- ▼ Lift the cap clear of the tank filler neck.

To close the fuel tank cap:

- ▼ Turn the key clockwise before pushing the cap back into the tank filler neck.
- ▼ Turn the key counterclockwise to lock and withdraw the key.
- ▼ Slide the cap cover back into place to hide the lock.

Filling the Fuel Tank

Fill the fuel tank slowly to help prevent spillage. Do not fill the tank to a level above the bottom of the filler neck. This will make sure there is enough air space to allow for fuel expansion if the fuel inside the tank expands through absorption of heat from the engine or from direct sunlight.

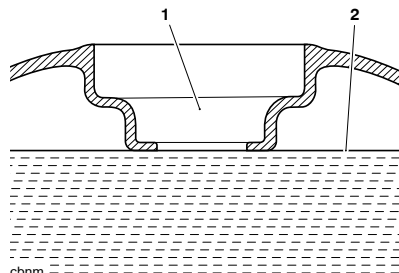

1. Fuel filler neck
2. Maximum fuel level

After refueling always check that the fuel tank cap is correctly closed.

Traction Control (TC)

WARNING

The traction control system is not a substitute for riding appropriately for the prevailing surface and weather conditions. The system cannot prevent loss of traction due to; excessive speed when entering turns, accelerating at a sharp lean angle and braking.

Traction control cannot prevent the front wheel from slipping.

Failure to follow the advice above may lead to loss of motorcycle control which could result in serious injury or death.

Traction control helps to maintain traction when accelerating on wet/slippy road surfaces. If sensors detect that the rear wheel is losing traction (slipping), the traction control system will engage and alter the engine power until traction to the rear wheel has been restored. The traction control warning light will flash while it is engaged and the rider may notice a change to the sound of the engine. Traction control will not function if there is a malfunction with the ABS. The warning lights for the ABS, traction control and the MIL will be illuminated.

NOTICE

Scrambler 400 X only: Traction control is switched off when in off-road mode.

Traction Control Settings

WARNING

Do not attempt to adjust the traction control settings while the motorcycle is in motion.

Adjusting the traction control settings while riding the motorcycle is dangerous.

Failure to follow the advice above may lead to loss of motorcycle control which could result in serious injury or death.

WARNING

If the traction control is disabled, the motorcycle will handle as normal but without traction control.

In this situation accelerating too hard on wet/slippy road surfaces may cause the rear wheel to slip.

Failure to follow the advice above may lead to loss of motorcycle control which could result in serious injury or death.

The traction control can be set to one of the following conditions:

ON	Optimal traction control setting for road use, allows minimal rear wheel slip.
OFF	Traction control is turned OFF. The TC disabled warning light will be illuminated (see page 30).

Traction control defaults to ON after the ignition has been switched OFF and then switched ON again.

To Disable the Traction Control

⚠ WARNING

After riding off-road with traction control disabled, always make sure that the traction control is enabled when returning to ride on public roads.

Riding on public roads with the traction control disabled may, if accelerating too hard on wet/slippery road surfaces, cause the rear wheel to slip.

Failure to follow the advice above may lead to loss of motorcycle control which could result in serious injury or death.

- ▼ Make sure the motorcycle is stationary and in neutral.
- ▼ Turn the ignition to the ON position and put the engine run/stop switch in the RUN position.
- ▼ Push and release the SCROLL/SELECT button on the left handlebar switch until 'ttcOn' is shown in the display.

- ▼ Push and hold the SCROLL/SELECT button for more than one second to change between traction control on and traction control off.

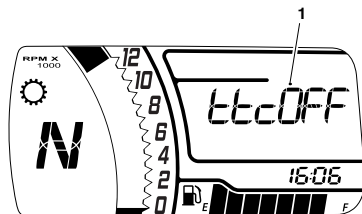

1. Traction control off display

Side Stand

⚠ WARNING

The motorcycle is equipped with an interlock system to prevent it from being ridden with the side stand in the down position.

Never attempt to ride with the side stand down or interfere with the interlock mechanism as this will cause a dangerous riding condition.

Failure to follow the advice above may lead to loss of motorcycle control which could result in serious injury or death.

⚠ CAUTION

Do not lean, sit or climb on the motorcycle when it is supported on the side stand.

This may cause the motorcycle to fall over.

Failure to follow the advice above could result in minor to moderate injury.

The motorcycle is equipped with a side stand on which it can be parked. When using the side stand, always turn the handlebars fully to the left and leave the motorcycle in first gear.

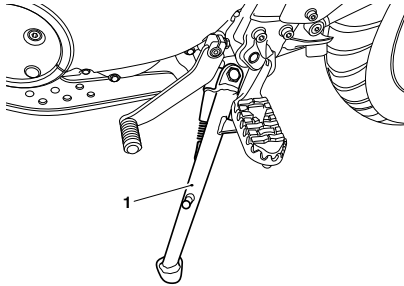

cont

1. Side stand (Scrambler 400 X shown)

Whenever the side stand is used, before riding, always make sure that the stand is fully up after first sitting on the motorcycle.

For instructions on safe parking, refer to the 'How to Ride the Motorcycle' section.

GENERAL INFORMATION

Side Panels

Side Panels - Removal

⚠ WARNING

Make sure the motorcycle is stabilized and adequately supported.

Do not support the motorcycle on any ancillary component, the exhaust system or any other non structural parts of the motorcycle frame.

A correctly supported motorcycle will help prevent it from falling.

An unstable motorcycle may fall resulting in motorcycle damage, serious injury or death.

- ▼ Remove the seat for Speed 400 and the rider and passenger seats for Scrambler 400 X, see page 57.
- ▼ Remove the fasteners at the top of both side panels.

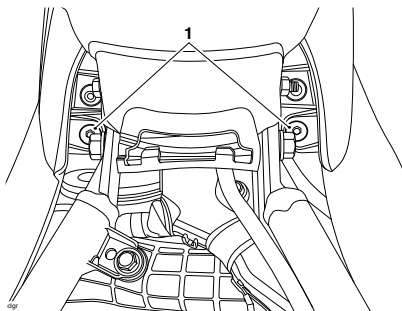

1. Fasteners

Left Hand Side Panel

To remove the left hand side panel:

- ▼ Grasp the panel firmly and pull the panel away from the motorcycle until it is free from the two retaining grommets (leaving the grommets in place).
- ▼ Lift the side panel upwards to remove from the lower hook.

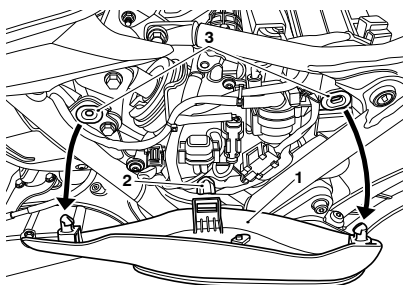

1. Side panel (Scrambler 400 X shown)
2. Hook
3. Grommets

Right Hand Side Panel

To remove the right hand side panel:

- ▼ Grasp the panel firmly and pull the panel away from the motorcycle until it is free from the two retaining grommets (leaving the grommets in place).

- ▼ Lift the side panel upwards to remove from the lower hook.

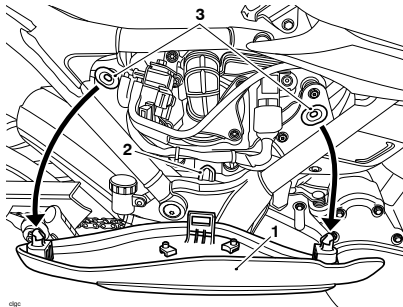

1. Side panel (Scrambler 400 X shown)
 2. Hook
 3. Grommets

Side Panel - Installation

WARNING

Make sure the motorcycle is stabilized and adequately supported.

Do not support the motorcycle on any ancillary component, the exhaust system or any other non structural parts of the motorcycle frame.

A correctly supported motorcycle will help prevent it from falling.

An unstable motorcycle may fall resulting in motorcycle damage, serious injury or death.

Left Hand Side Panel

To install the left hand side panel:

- ▼ Position the bottom of the side panel onto the lower hook.
- ▼ Position the two locating dowels to the grommets, then press firmly to secure the panel.
- ▼ Install the fastener at the top of the side panel and tighten to 40 lbf in (4.5 Nm).
- ▼ Finally, grasp the panel and make sure it is fully retained.

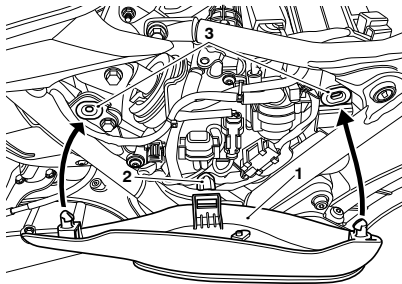

1. Side panel (Scrambler 400 X shown)
 2. Hook
 3. Grommets

GENERAL INFORMATION

Right Hand Side Panel

To install the right hand side panel:

- ▼ Position the bottom of the side panel onto the lower hook.
- ▼ Position the two locating dowels to the grommets, then press firmly to secure the panel.
- ▼ Install the fastener at the top of the side panel and tighten to 40 lbf in (4.5 Nm).
- ▼ Finally, grasp the panel and make sure it is fully retained.

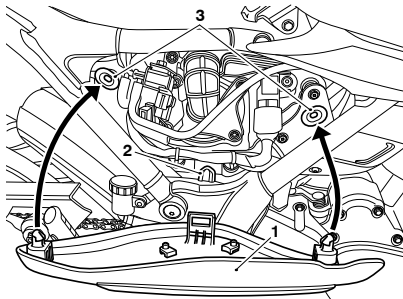

opt

1. Side panel (Scrambler 400 X shown)
 2. Hook
 3. Grommets
- ▼ Reinstall the seat for Speed 400 and the rider and passenger seats for Scrambler 400 X, see page 58.

Seats

Seat Care

NOTICE

To prevent damage to the seats or seat covers, care must be taken not to drop the seats.

Do not lean the seats against the motorcycle or any surface which may damage the seats or seat covers. Instead, place the seats, with the seat cover facing upwards, on a clean, flat surface which is covered with a soft cloth.

Do not place any item on the seats which may cause damage or staining to the seat covers.

For seat cleaning information, see page 143.

Seat Lock

WARNING

To prevent detachment of the seat during riding, after installation always grasp the seat and pull firmly upwards.

If the seat is not correctly secured in the lock, it will detach from the lock.

A loose or detached seat may lead to loss of motorcycle control which could result in serious injury or death.

NOTICE

The motorcycle must not be ridden with the key in the seat lock.

Always lock the seat and remove the key before riding the motorcycle.

The seat lock is located on the left hand side of the motorcycle, on the frame below the seat.

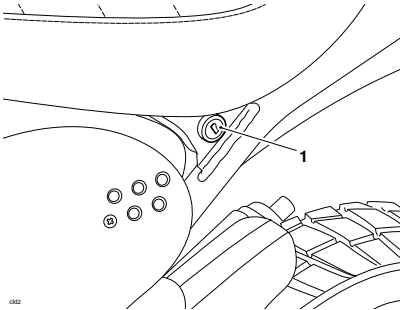

1. Seat lock (Scrambler 400 X shown)

The seat can be removed to gain access to the battery and fuse box.

Seat - Removal

WARNING

Make sure the motorcycle is stabilized and adequately supported.

Do not support the motorcycle on any ancillary component, the exhaust system or any other non structural parts of the motorcycle frame.

A correctly supported motorcycle will help prevent it from falling.

An unstable motorcycle may fall resulting in motorcycle damage, serious injury or death.

NOTICE

To prevent damage to the seats or seat covers, care must be taken not to drop the seats.

Do not lean the seats against the motorcycle or any surface which may damage the seats or seat covers. Instead, place the seats, with the seat cover facing upwards, on a clean, flat surface which is covered with a soft cloth.

Do not place any item on the seats which may cause damage or staining to the seat covers.

Speed 400

Seat

- ▼ Insert the ignition key into the seat lock.
- ▼ Turn the ignition key clockwise while pressing down on the rear of the seat. This will release the seat from its lock.
- ▼ Lift the seat up from the back and slide rearwards for complete removal from the motorcycle.

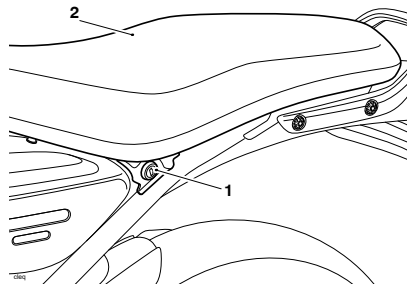

1. Seat lock
2. Seat

Scrambler 400 X

Passenger Seat

NOTICE

The passenger seat must be removed before removing the rider's seat.

- ▼ Insert the ignition key into the seat lock.
- ▼ Turn the ignition key clockwise while pressing down on the rear of the seat. This will release the passenger seat from its lock.
- ▼ Lift the seat up from the back and slide rearwards for complete removal from the motorcycle.

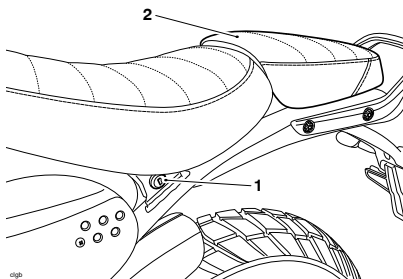

1. Seat lock
2. Passenger seat

Rider's Seat

- ▼ Remove the passenger seat as described above.
- ▼ Remove the fasteners at the rear of the seat.

- ▼ Lift the seat up from the back and slide rearwards for complete removal from the motorcycle.

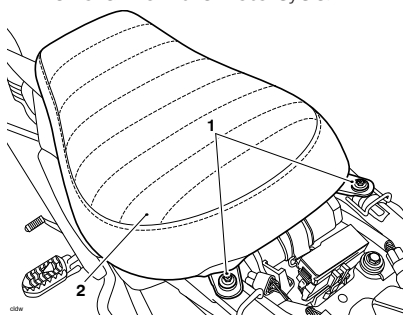

1. Fasteners
2. Rider's seat

Seat - Installation

WARNING

Make sure the motorcycle is stabilized and adequately supported.

Do not support the motorcycle on any ancillary component, the exhaust system or any other non structural parts of the motorcycle frame.

A correctly supported motorcycle will help prevent it from falling.

An unstable motorcycle may fall resulting in motorcycle damage, serious injury or death.

Speed 400**Seat**

- ▼ Engage the hook at the front of the seat under the bracket at the rear of the fuel tank.

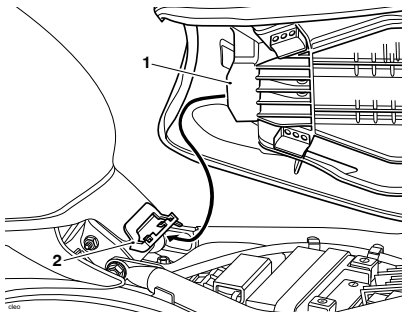

1. Hook
2. Bracket

- ▼ Align the locating peg into the lock and press down engaging the seat lock.

NOTICE

An audible click can be heard when the seat is fully engaged in its lock.

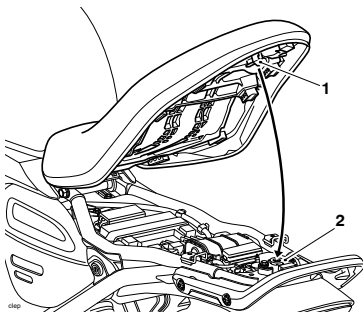

1. Locating peg
2. Lock

WARNING

To prevent detachment of the seat during riding, after installation always grasp the seat and pull firmly upwards. If the seat is not correctly secured in the lock, it will detach from the lock.

A loose or detached seat may lead to loss of motorcycle control which could result in serious injury or death.

- ▼ Grasp the seat and pull firmly upwards to make sure it is securely retained.

Scrambler 400 X**Rider's Seat**

- ▼ Engage the hook at the front of the seat under the bracket at the rear of the fuel tank.

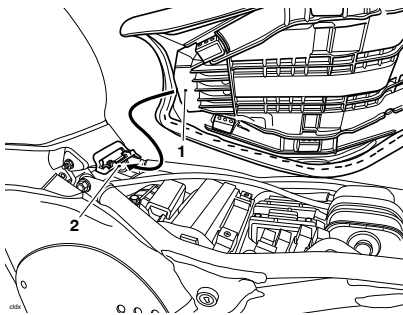

1. Hook
2. Bracket

- ▼ Lower the rear of seat and align the holes for the fasteners.

- ▼ Install the fasteners at the rear of the seat and tighten to 40 lbf in (4.5 Nm).

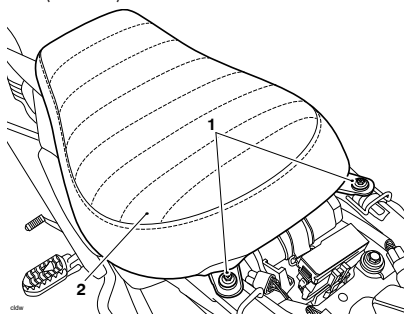

1. Fasteners
2. Rider's seat

⚠ WARNING

Never ride the motorcycle with the fasteners loose or removed, as the rider's seat will not be secure and can move.

The rider's seat is only correctly retained and supported when the fasteners are correctly tightened.

A loose or detached seat may lead to loss of motorcycle control which could result in serious injury or death.

- ▼ Grasp the seat and pull firmly upwards to make sure it is securely retained.
- ▼ Install the passenger seat as follows.

Passenger Seat

- ▼ Engage the two hooks at the front of the seat under the two loops on the subframe.
- ▼ Align the locating peg into the lock and press down engaging the seat lock.

NOTICE

An audible click can be heard when the seat is fully engaged in its lock.

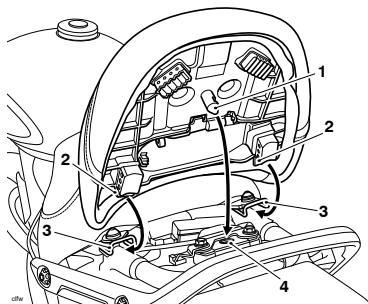

1. Locating peg
2. Hooks
3. Loops
4. Lock

⚠ WARNING

Never ride the motorcycle with the passenger seat detached or removed.

To prevent detachment of the seat during riding, after installation always grasp the seat and pull firmly upwards.

If the seat is not correctly secured it will detach from the lock. A loose or detached seat may lead to loss of motorcycle control which could result in serious injury or death.

- ▼ Grasp the seat and pull firmly upwards to make sure it is securely retained.

Owner's Handbook and Tool Kit

Owner's Handbook/Quick Start Guide

The Owner's Handbook or Quick Start Guide is supplied with the motorcycle.

Tool Kit

The tool kit is located on the underside of the seat.

The tool kit includes a:

- ▼ 0.67 in (17 mm) spanner (Scrambler 400 X only)
- ▼ Combination 0.2 in (5 mm) Allen key and screwdriver
- ▼ Rear suspension unit spring preload adjustment tool (not stored in tool kit).

Universal Serial Bus (USB) Socket

DANGER

Do not use a mobile phone or adjust any GPS device while the motorcycle is in motion.

Telephone calls, texting or any attempt to use your mobile device for any purpose while riding the motorcycle is dangerous.

Failure to follow the advice above will result in serious injury or death.

WARNING

Make sure that all electronic devices and adapter cables are safely secured when riding. Check adapter cables do not bind or restrict the operation of the steering and other controls.

Electronic devices and adapter cables that are not secure may restrict the movement of the steering and affect the handling, stability or other aspect of the motorcycle operation.

Any electronic devices or adapter cables that will restrict the steering and other controls may lead to loss of motorcycle control which could result in serious injury or death.

NOTICE

The USB socket is susceptible to water ingress with the cover open. Do not connect adapter cables to the USB socket while it is raining or in wet conditions.

Water in the USB socket could lead to corrosion which may adversely affect the function of the device.

NOTICE

Do not leave the ignition switch in the ON position unless the engine is running as this will discharge the battery.

The Universal Serial Bus (USB) socket allows a 5 Volt USB-C connection for charging electronic devices such as mobile phones, cameras and GPS devices.

Loads up to a maximum of 2.4 Amps can be connected to the USB-C socket.

To access the USB-C socket:

- ▼ The USB-C socket is located on the right hand side, adjacent to the ignition switch and above the headlight.

- ▼ Remove the cover.

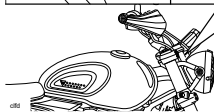
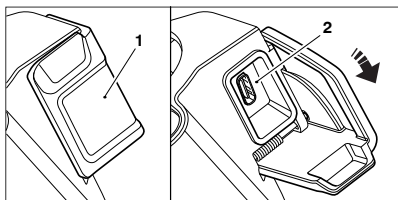

1. **USB-C cover (Scrambler 400 X shown)**
2. **USB-C socket**

- ▼ Plug the USB-C adapter cable into the socket.

NOTICE

Adapter cables are not supplied with the motorcycle.

Breaking-In



Breaking-in is the name given to the process that occurs during the first hours of a new vehicle's operation.

In particular, internal friction in the engine will be higher when components are new. Later on, when continued operation of the engine has ensured that the components have 'bedded in', this internal friction will be greatly reduced.

A period of careful breaking-in will ensure lower exhaust emissions, and will optimize performance, fuel economy and longevity of the engine and other motorcycle components.

During the first 600 miles (1,000 km):

- ▼ Do not use full throttle
- ▼ Avoid high engine speeds at all times
- ▼ Avoid riding at one constant engine speed, whether fast or slow, for a long period of time
- ▼ Avoid aggressive starts, stops, and rapid accelerations, except in an emergency
- ▼ Do not ride at engine speeds greater than 6,500 rpm. The tachometer will flash when the engine speed reaches 6,500 rpm and above.

From 600 to 1,000 miles (1,000 to 1,500 km):

- ▼ Engine speed can gradually be increased to the maximum engine speed for short periods.

Both during and after breaking-in has been completed:

- ▼ Do not over-rev the engine when cold
- ▼ Do not lug the engine. Always downshift before the engine begins to 'struggle'
- ▼ Do not ride with engine speeds unnecessarily high. Shifting up a gear helps reduce fuel consumption, reduces noise and helps to protect the environment.

GENERAL INFORMATION

Daily Safety Checks



WARNING

Always perform the daily safety checks every day before you ride the motorcycle.

Failure to perform these daily safety checks may lead to loss of motorcycle control which could result in motorcycle damage, serious injury or death.

Check the following items each day before you ride. The time required is minimal, and these checks will help ensure a safe, reliable ride.

If any doubt exists, refer to the Maintenance section or contact a competent person with the specialist knowledge and technical understanding of motorcycles, such as an authorized Triumph dealer.

Check:

Fuel: Adequate supply in tank, no fuel leaks (see page 48).

Engine Oil: Correct level on dipstick or shown in sight glass. Add correct specification oil as required. No leaks from the engine or oil cooler (see page 89).

Drive Chain: Correct adjustment (see page 102).

Tires/Wheels: Correct inflation pressures (when cold). Tread depth/wear, tire/wheel damage, loose/broken spokes, punctures etc. (see page 121).

Nuts, Bolts, Fasteners: Visually check that steering and suspension components, axles, and all controls are properly tightened or fastened. Inspect all areas for loose/damaged fasteners.

Steering Action: Smooth but not loose from lock to lock. No binding of any of the control cables (see page 115).

Brakes: Pull the brake lever and push the brake pedal to check for correct resistance. Investigate any lever/pedal where the travel is excessive before meeting resistance, or if either control feels spongy in operation (see page 106).

Brake Pads: Check that the correct amount of friction material is remaining on all the brake pads (see page 106 and page 108).

Brake Fluid Levels: No brake fluid leakage. Brake fluid levels must be between the MAX and MIN marks on both reservoirs (see page 110 and page 111).

Front Forks: Smooth action. No fork oil leakage (see page 118).

Throttle: Make sure that the throttle grip returns to the idle position without sticking (see page 98).

Clutch: Smooth operation and correct cable free play (see page 99).

Coolant: No coolant leakage. Check the coolant level in the expansion tank (when the engine is cold) (see page 96).

Electrical Equipment: All lights and horn function correctly (see page 46).

Engine Stop: Engine run/stop switch turns the engine OFF when the switch is moved to the STOP position (see page 45).

Stands: Returns to the fully up position by spring tension. Return springs not weak or damaged (see page 53).

Table of Contents

Stopping the Engine.....	66
Starting the Engine.....	66
Moving Off.....	68
Shifting Gears.....	68
Braking.....	69
Anti-lock Braking System (ABS).....	71
Parking.....	73
Considerations for High Speed Operation.....	74

HOW TO RIDE THE MOTORCYCLE

Stopping the Engine

⚠ WARNING

Do not stop the engine using the ignition switch or engine stop switch while the motorcycle is moving.

Always bring the motorcycle to a stop safely and engage Neutral gear prior to stopping the engine.

Stopping the engine by turning off the ignition or engine stop switch while the motorcycle is moving can lock the rear wheel, leading to loss of motorcycle control which could result in serious injury or death.

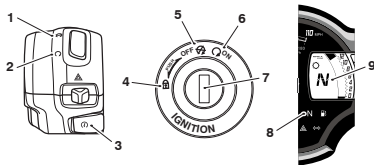

1. **STOP position**
2. **RUN position**
3. **START button**
4. **LOCK position**
5. **OFF position**
6. **ON position**
7. **Ignition switch**
8. **Neutral indicator light**
9. **Gear position display (neutral shown)**

- ▼ Close the throttle completely.
- ▼ Select neutral.
- ▼ Turn the ignition switch off.
- ▼ Select first gear.
- ▼ Position the motorcycle on a firm, level surface with the side stand (see page 73).
- ▼ Lock the steering (see page 42).

Starting the Engine

⚠ DANGER

Never start the engine or run the engine in a confined area.

Always operate the motorcycle in the open air or in an area with adequate ventilation.

Exhaust fumes are poisonous and will cause loss of consciousness and death within a short period of time.

NOTICE

Do not operate the starter continuously for more than five seconds as the starter motor will overheat and the battery will become discharged.

Wait 15 seconds between each operation of the starter to allow for cooling and recovery of battery power.

Do not let the engine idle for long periods as this may lead to overheating which will cause damage to the engine.

NOTICE

The low oil pressure warning light should go out shortly after the engine starts.

If the low oil pressure warning light remains on after starting the engine, stop the engine immediately and investigate the cause.

Running the engine with low oil pressure will cause severe engine damage.

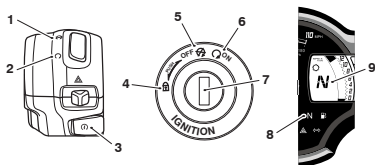

1. **STOP position**
2. **RUN position**
3. **START button**
4. **LOCK position**
5. **OFF position**
6. **ON position**
7. **Ignition switch**
8. **Neutral indicator light**
9. **Gear position display (neutral shown)**

- ▼ Check that the engine stop switch is in the RUN position.
- ▼ Make sure the transmission is in neutral.
- ▼ Turn the ignition switch on.

- ▼ Pull the clutch lever fully into the handlebar.
- ▼ Leaving the throttle fully closed, push the START button until the engine starts.
- ▼ The motorcycle is equipped with starter lockout switches. The switches prevent the electric starter from operating when the transmission is not in neutral with the side stand down.
- ▼ If the side stand is extended while the engine is running, and the transmission is not in neutral then the engine will stop regardless of the clutch lever position.

NOTICE

When the ignition is switched on, the instrument warning lights will illuminate and will then go off (except those which normally remain on until the engine starts, see page 27).

HOW TO RIDE THE MOTORCYCLE

Moving Off

- ▼ Pull in the clutch lever and select first gear.
- ▼ Open the throttle a little and let out the clutch lever slowly.
- ▼ As the clutch starts to engage, open the throttle a little more, allowing enough engine speed to avoid stalling.

Shifting Gears

⚠ WARNING

Take care to avoid opening the throttle too far or too fast in any of the lower gears as this can lead to the front wheel lifting from the ground (pulling a 'wheelie') and to the rear tire breaking traction (wheel spin).

Always open the throttle cautiously, particularly if you are unfamiliar with the motorcycle.

Pulling a 'wheelie' or loss of traction may lead to loss of motorcycle control which could result in serious injury or death.

⚠ WARNING

Do not shift to a lower gear at speeds that will cause excessive engine rpm (r/min).

Shifting down should be done such that low engine speeds will be ensured.

Shifting to a lower gear at high speed can lock the rear wheel, leading to loss of motorcycle control which could result in serious injury or death.

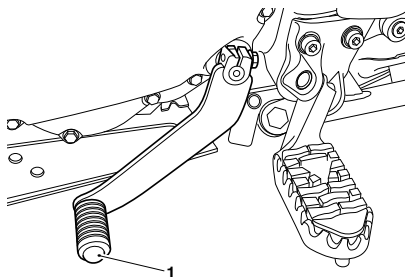

1. Gear shift pedal (Scrambler 400 X shown)

- ▼ Close the throttle while pulling in the clutch lever.
- ▼ Shift into the next higher or lower gear.
- ▼ Open the throttle part way, while releasing the clutch lever.
- ▼ Always use the clutch when shifting gear.

NOTICE

The gear shift mechanism is the 'positive stop' type. This means that, for each movement of the gear shift pedal, you can only select each gear, one after the other, in ascending or descending order.

Braking

WARNING

WHEN BRAKING, OBSERVE THE FOLLOWING:

- Close the throttle completely, leaving the clutch engaged to allow the engine to help slow down the motorcycle.
- Shift down one gear at a time such that the transmission is in first gear when the motorcycle comes to a complete stop.
- When stopping, always apply both brakes at the same time. Normally the front brake should be applied a little more than the rear.
- Shift down or fully disengage the clutch as necessary to keep the engine from stalling.
- Never lock the brakes, as this may cause loss of control of the motorcycle.

Failure to follow the advice above could result in serious injury or death.

WARNING

For emergency braking, disregard down shifting, and concentrate on applying the front and rear brakes as hard as possible without skidding.

Riders should practice emergency braking in a traffic-free area.

Triumph strongly recommends that all riders take a course of instruction, which includes advice on safe brake operation. Incorrect brake technique may lead to loss of motorcycle control which could result in serious injury or death.

WARNING

For your safety, always exercise extreme caution when braking, accelerating or turning as any improper action can cause loss of motorcycle control and an accident. Independent use of the front or rear brakes reduces overall braking performance. Extreme braking may cause either wheel to lock, reducing control of the motorcycle and causing an accident (see ABS warnings).

When possible, reduce speed or brake before entering a turn as closing the throttle or braking in mid-turn may cause wheel slip leading to loss of control.

When riding in wet or rainy conditions, or on loose surfaces, the ability to maneuver and stop will be reduced. All of your actions should be smooth under these conditions. Sudden acceleration, braking or turning may cause loss of motorcycle control.

Failure to follow the advice above may lead to loss of motorcycle control which could result in serious injury or death.

HOW TO RIDE THE MOTORCYCLE

⚠ WARNING

When descending a long, steep gradient or mountain pass, make use of the engine's braking effect by down shifting and use both front and rear brakes intermittently.

Continuous brake application or use of the rear brake only can overheat the brakes and reduce their effectiveness.

Failure to follow the advice above may lead to loss of motorcycle control which could result in serious injury or death.

⚠ WARNING

Riding with your foot on the brake pedal or your hands on the brake lever may actuate the brake light, giving a false indication to other road users.

It may also overheat the brake, reducing braking effectiveness.

Failure to follow the advice above may lead to loss of motorcycle control which could result in serious injury or death.

⚠ WARNING

Do not coast with the engine switched off, and do not tow the motorcycle.

The transmission is pressure lubricated only when the engine is running.

Inadequate lubrication may cause damage or seizure of the transmission, leading to loss of motorcycle control which could result in serious injury or death.

⚠ WARNING

When using the motorcycle on loose, wet or muddy roads, braking effectiveness will be reduced by dust, mud or moisture collecting on the brakes.

Always brake earlier in these conditions to make sure that brake surfaces are cleaned by the braking action.

Riding the motorcycle with brakes contaminated with dust, mud or moisture may lead to loss of motorcycle control which could result in serious injury or death.

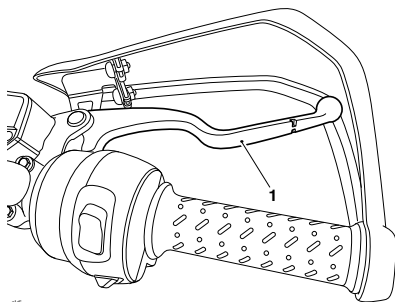

1. Front brake lever (Scrambler 400 X shown)

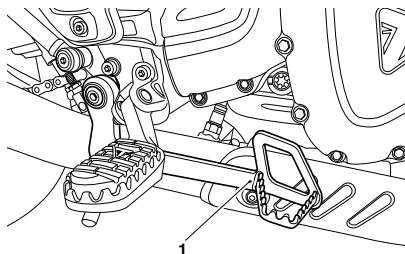

1. Rear brake pedal (Scrambler 400 X shown)

Anti-lock Braking System (ABS)

WARNING

The ABS function attempts to maximize the chances of keeping the motorcycle under control when braking. The potentially shorter braking distances, ABS allows under certain conditions, are not a substitute for good riding practice.

Always ride within the legal speed limit.

Never ride without due care and attention and always reduce speed in consideration of weather, road and traffic conditions.

Under some circumstances it is possible that a motorcycle equipped with ABS may require a longer stopping distance.

Take care when cornering. If the brakes are applied in a corner, ABS will not be able to counteract the weight and momentum of the motorcycle.

Failure to follow the advice above may lead to loss of motorcycle control which could result in serious injury or death.

WARNING

If the ABS is not functioning or has been disabled (off-road mode for Scrambler 400 X only), the brake system will continue to function as a non-ABS braking system. Do not continue to ride for longer than is necessary with the ABS warning light illuminated.

In the event of a fault, contact a competent person with the specialist knowledge and technical understanding of motorcycles, such as an authorized Triumph dealer as soon as possible to have the fault checked and rectified.

Braking too hard will cause the wheels to lock, leading to loss of motorcycle control which could result in serious injury or death.

WARNING

After riding off-road with ABS disabled, always make sure that the ABS is enabled when returning to ride on public roads.

Riding on public roads with the ABS disabled will, if braking too hard, cause the wheels to lock.

Failure to follow the advice above may lead to loss of motorcycle control which could result in serious injury or death.

HOW TO RIDE THE MOTORCYCLE

WARNING

ABS operates by comparing the relative speed of the front and rear wheels.

Use of non-recommended tires can affect wheel speed and cause the ABS not to operate. Always install recommended tires.

Failure to follow the advice above may lead to loss of motorcycle control which could result in serious injury or death.

NOTICE

The ABS operation may feel like a harder pedal pressure or a pulsation of the brake lever and pedal.

The ABS is not an integrated braking system and does not control both the front and rear brake at the same time so this pulsation may be felt in the lever, the pedal or both.

The ABS may be activated by sudden upward or downward changes in the road surface.

ABS Warning Light



When the ignition switch is turned to the ON position, it is normal that the ABS warning light will be illuminated. The light will remain on until the motorcycle first reaches a speed exceeding 6 mph (10 km/h) when it will go off.

The warning light will not illuminate again until the engine is restarted unless there is a fault, or the ABS is disabled by the rider (off-road mode for Scrambler 400 X only).

Scrambler 400 X only: If the ABS is disabled by the rider (off-road mode), the warning light will remain illuminated until the ABS is enabled again.

If there is a fault with the ABS system the warning light will be illuminated and the general warning symbol will flash.

NOTICE

The ABS warning light will illuminate when the rear wheel is driven at high speed for more than 30 seconds when the motorcycle is on a stand. This reaction is normal.

When the ignition is switched off and the motorcycle is restarted, the warning light will illuminate until the motorcycle reaches a speed exceeding 19 mph (30 km/h).

Parking

⚠ WARNING

Gasoline is extremely flammable and can be explosive under certain conditions.

If parking inside a garage or other structure, be sure it is well ventilated and the motorcycle is not close to any source of flame or sparks. This includes any appliance with a pilot light.

Failure to follow the above advice may cause a fire resulting in damage to property, serious injury or death.

⚠ CAUTION

The engine and exhaust system will be hot after riding.

DO NOT park where pedestrians and children are likely to touch the motorcycle.

Touching any part of the engine or exhaust system when hot could result in minor to moderate injury.

⚠ CAUTION

Take care when parking on soft ground or on a steeply inclined surface.

Parking under these conditions may cause the motorcycle to fall over which could result in minor to moderate injury.

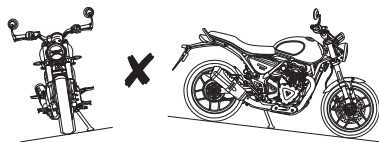
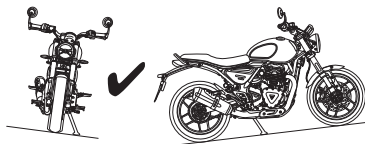

Speed 400 Shown

- ▼ Select neutral and turn the ignition switch to the OFF position.
- ▼ Lock the steering to help prevent theft.
- ▼ Always park on a firm, level surface to prevent the motorcycle from falling.
- ▼ When parking on a hill, always park facing uphill to prevent the motorcycle from rolling off the stand. Engage first gear to prevent the motorcycle from moving.
- ▼ On a lateral (sideways) incline, always park such that the incline naturally pushes the motorcycle towards the side stand.
- ▼ Do not park on a lateral (sideways) incline of greater than 6° and never park facing downhill.
- ▼ Make sure that the side stand is fully retracted before riding off.

HOW TO RIDE THE MOTORCYCLE

Considerations for High Speed Operation

WARNING

This motorcycle should be operated within the legal speed limits for the particular road traveled.

Riding a motorcycle at high speeds can be dangerous since the time available to react to a hazard is greatly reduced at high speeds.

Always reduce speed in potentially hazardous driving conditions such as bad weather or heavy traffic.

Failure to follow the advice above may lead to loss of motorcycle control which could result in serious injury or death.

WARNING

Only operate this motorcycle at high speed in closed-course, on-road competition or on closed-course racetracks.

High speed operation should only then be attempted by riders who have been instructed in the techniques necessary for high speed riding and are familiar with the motorcycle's characteristics in all conditions.

High speed operation in any other circumstances is dangerous and may lead to loss of motorcycle control which could result in serious injury or death.

WARNING

The handling characteristics of a motorcycle at high speed may vary from those you are familiar with at legal road speeds.

Do not attempt high speed operation unless you have received sufficient training and have the required skills.

Failure to follow the advice above may lead to loss of motorcycle control which could result in serious injury or death.

WARNING

The items listed below are extremely important and must never be neglected.

A problem, which may not be noticed at normal operating speeds, may be greatly exaggerated at high speeds.

Check the items listed below before any high speed operation.

Failure to follow the advice above may lead to loss of motorcycle control which could result in serious injury or death.

General

Make sure that the motorcycle has been maintained according to the scheduled maintenance chart.

Brakes

Check that the front and rear brakes are functioning correctly.

Coolant

Check that the coolant level is at the upper level line in the expansion tank. Always check the level with the engine cold.

Electrical Equipment

Make sure that all electrical equipment such as the headlight, rear/brake light, turn signals and horn all work correctly.

Engine Oil

Check that the engine oil level is correct. Make sure that the correct grade and type of oil is used when topping off.

Drive Chain

Make sure that the drive chain is correctly adjusted and lubricated. Inspect the chain for wear and damage.

Fuel

NOTICE

In many countries, the exhaust system for this model is equipped with a catalytic converter to help reduce exhaust emission levels.

Use of leaded fuel will damage the catalytic converter. In addition, the catalytic converter can be permanently damaged if the motorcycle is allowed to run out of fuel or if the fuel level is allowed to get very low.

Always make sure you have adequate fuel for your trip.

Have sufficient fuel for the increased fuel consumption that will result from high speed operation.

Luggage

Make sure that any luggage containers are closed, locked and securely installed on the motorcycle.

Miscellaneous

Visually check that all fasteners are tight.

Steering

Check that the handlebar turns smoothly without excessive free play or tight spots. Make sure that the control cables do not restrict the steering in any way.

Tires

High speed operation is hard on tires, and tires that are in good condition are crucial to riding safely. Examine their overall condition, inflate to the correct pressure (when the tires are cold), and check the wheel balance. Securely install the valve caps after checking tire pressures. Observe the information given in the maintenance and specification sections on tire checking and tire safety.

This page intentionally left blank

The addition of accessories and carrying of additional weight can affect the motorcycle's handling characteristics causing changes in stability and necessitating a reduction in speed. The following information has been prepared as a guide to the potential hazards of adding accessories to a motorcycle and carrying passengers and additional loads.

Accessories

WARNING

Do not install accessories or carry luggage that impairs the control of the motorcycle.

Make sure that you have not adversely affected any lighting component, road clearance, banking capability (i.e. lean angle), control operation, wheel travel, front fork movement, visibility in any direction, or any other aspect of the motorcycle's operation.

Failure to follow the advice above may lead to loss of motorcycle control which could result in serious injury or death.

WARNING

Install only genuine Triumph accessories to the correct Triumph motorcycle model.

Always check the Triumph Installation Instruction associated with the genuine Triumph accessory. Make sure the Triumph motorcycle model that the Triumph accessory is to be installed on, is listed as approved for the genuine Triumph accessory. For all Triumph Installation Instructions, see www.triumphinstructions.com.

Never install genuine Triumph accessories to a Triumph motorcycle model that is not listed in the associated Triumph Fitting Instruction, as this may affect handling, stability or other aspects of the motorcycle operation that may lead to loss of motorcycle control which could result in serious injury or death.

! WARNING

Owners should be aware that the only approved parts, accessories and conversions for any Triumph motorcycle are those which carry official Triumph approval.

We recommend accessories and conversions be completed by a competent person with the specialist knowledge and technical understanding of motorcycles, such as an authorized Triumph dealer.

In particular, it is extremely hazardous to install or replace parts or accessories whose installation requires the dismantling of, or addition to, either the electrical or fuel systems and any such modification could cause a safety hazard.

The installation of any non-approved parts, accessories or conversions may affect the handling, stability or other aspect of the motorcycle operation, leading to loss of motorcycle control which could result in serious injury or death.

Triumph does not accept any liability whatsoever for defects caused by the installation of non-approved parts, accessories or conversions.

Triumph does not accept any liability whatsoever for defects caused by the incorrect installation of approved parts, accessories or conversions.

! WARNING

Never ride an accessory equipped motorcycle, or a motorcycle carrying a payload of any kind, at speeds above 80 mph (130 km/h). In either/both of these conditions, speeds in excess of 80 mph (130 km/h) should not be attempted even where the legal speed limit permits this.

The presence of accessories and/or payload will cause changes in the stability and handling of the motorcycle.

Failure to allow for changes in motorcycle stability may lead to loss of motorcycle control. When riding at high speed, always be aware that various motorcycle configuration and environmental factors can adversely affect the stability of your motorcycle. For example:

- Incorrectly balanced loads on both sides of the motorcycle
- Incorrectly adjusted front and rear suspension settings
- Incorrectly adjusted tire pressures
- Excessively or unevenly worn tires
- Side winds and turbulence from other vehicles
- Loose clothing.

Remember that the 80 mph (130 km/h) absolute limit will be reduced by the installation of non-approved accessories, incorrect loading, worn tires, overall motorcycle condition and poor road or weather conditions.

Failure to follow the advice above may lead to loss of motorcycle control which could result in serious injury or death.

Loading

⚠ WARNING

Never attempt to store any items between the frame and the fuel tank. This may restrict the steering aspect of the motorcycle.

Weight attached to the handlebar or front fork will increase the mass of the steering assembly. This may affect the handling, stability or other aspect of the motorcycle operation.

Failure to follow the advice above may lead to loss of motorcycle control which could result in serious injury or death.

⚠ WARNING

Do not carry liquids in containers on your motorcycle.

Liquids are not stable and will adversely affect the motorcycle stability.

Failure to follow the advice above may lead to loss of motorcycle control which could result in serious injury or death.

⚠ WARNING

The maximum safe load for each pannier is stated on a label inside the pannier and must not be exceeded.

Exceeding this loading limit may affect the handling, stability or other aspect of the motorcycle operation.

Failure to follow the advice above may lead to loss of motorcycle control which could result in serious injury or death.

⚠ WARNING

Do not use the passenger seat to carry any objects.

Carrying objects on the passenger seat may adversely affect the motorcycle stability.

Failure to follow the advice above may lead to loss of motorcycle control which could result in serious injury or death.

⚠ WARNING

Always make sure that any loads carried are evenly distributed on both sides of the motorcycle. Make sure that the load is correctly secured so that it will not move around while the motorcycle is in motion.

Evenly distribute the load within each pannier (if equipped). Pack heavy items at the bottom and on the inboard side of the pannier.

Always check the load security regularly (though not while the motorcycle is in motion) and make sure that the load does not extend beyond the rear of the motorcycle.

Never exceed the maximum vehicle loading weight as specified in the Specifications section.

This maximum loading weight is made up from the combined weight of the rider, passenger, any accessories installed and any load carried.

For models that have adjustable suspension settings, make sure that front and rear spring preload and damping settings are suitable for the loading condition of the motorcycle. Note the maximum permissible payload for the panniers is stated on a label inside the pannier.

Failure to follow the advice above may lead to loss of motorcycle control which could result in serious injury or death.

Passengers**⚠ WARNING**

This motorcycle is designed for use as a two-wheeled vehicle capable of carrying a rider and up to one passenger (subject to a passenger seat and footrests being installed).

The total weight of the rider, and any passenger, accessories and luggage must not exceed the maximum load limit as specified in the Specifications section.

Failure to follow the advice above may lead to loss of motorcycle control which could result in serious injury or death.

⚠ WARNING

The handling and braking capabilities of a motorcycle will be affected by the presence of a passenger.

The rider must make allowances for these changes when operating the motorcycle with a passenger and should not attempt such operation unless trained to do so and without becoming familiar and comfortable with the changes in motorcycle operating characteristics that this brings about.

Failure to follow the advice above may lead to loss of motorcycle control which could result in serious injury or death.

WARNING

Do not carry a passenger unless they are tall enough to reach the footrests provided.

A passenger who is not tall enough to reach the footrests will be unable to sit securely on the motorcycle and may cause instability, leading to loss of motorcycle control which could result in serious injury or death.

WARNING

Do not carry animals on your motorcycle.

An animal could make sudden and unpredictable movements that may lead to loss of motorcycle control which could result in serious injury or death.

WARNING

Your passenger should be instructed that they can cause loss of motorcycle control by making sudden movements or by adopting an incorrect seated position.

The rider should instruct the passenger as follows:

- It is important that the passenger sits still while the motorcycle is in motion and does not interfere with the operation of the motorcycle.
- To keep their feet on the passenger footrests and to firmly hold onto either the seat strap or grab rails (if equipped) or the rider's waist or hips.
- Advise the passenger to lean with the rider when traveling around corners and not to lean unless the rider does so.

Failure to follow the advice above may lead to loss of motorcycle control which could result in serious injury or death.

This page intentionally left blank

Table of Contents

Scheduled Maintenance	85
Disposal of Used Fluids	86
Scheduled Maintenance Table	87
Engine Oil	89
Engine Oil Level Inspection	89
Engine Oil and Oil Filter Change	90
Engine Oil Specification and Grade (10W/50)	94
Cooling System	95
Coolant Level Inspection	96
Coolant Level Adjustment	96
Coolant Change	97
Radiator and Hoses	98
Throttle Control	98
Throttle Inspection	98
Clutch	99
Clutch Inspection	99
Clutch Cable Adjustment	99
Drive Chain	101
Drive Chain Lubrication	101
Drive Chain Free Movement Inspection	102
Drive Chain Free Movement Adjustment	102
Drive Chain and Sprocket Wear Inspection	103
Brakes	106
Front Brake Wear Inspection	106
Breaking-in New Brake Discs and Pads	107
Brake Pad Wear Compensation	108
Rear Brake Wear Inspection	108
Disc Brake Fluid	109
Front Brake Fluid Level Inspection and Adjustment	110
Rear Brake Fluid Level Inspection and Adjustment	111
Brake Light Switches	112
Mirrors	113
Mirror Adjustment	114
Steering/Wheel Bearings	115
Steering Bearings Inspection	115
Wheel Bearings Inspection	116
Front Suspension	118
Front Fork Inspection	118

MAINTENANCE AND ADJUSTMENT

Rear Suspension.....	119
Rear Suspension Settings.....	119
Rear Suspension Spring Preload Adjustment.....	119
Bank Angle Indicators.....	120
Tires.....	121
Tire Inflation Pressures.....	122
Tire Wear.....	122
Minimum Recommended Tread Depth.....	122
Tire Replacement.....	123
Battery.....	126
Battery - Removal.....	126
Battery Disposal.....	127
Battery Maintenance.....	128
Battery Discharge.....	128
Battery Discharge During Storage and Infrequent Use of the Motorcycle.....	128
Battery Charging.....	129
Battery - Installation.....	130
Fuses.....	131
Fuse Identification.....	132
Lights.....	133
Headlight(s).....	133
Brake/Tail Light.....	135
Turn Signal Lights.....	135
License Plate Light.....	135

Scheduled Maintenance

WARNING

Triumph Motorcycles cannot accept any responsibility for damage or injury resulting from incorrect maintenance or improper adjustment.

Scheduled maintenance must be carried out by a competent person with the specialist knowledge and technical understanding of motorcycles, such as an authorized Triumph dealer.

Incorrect or neglected maintenance may lead to a dangerous riding condition, leading to loss of motorcycle control which could result in serious injury or death.

WARNING

All maintenance is vitally important and must not be neglected. Incorrect maintenance or adjustment may cause one or more parts of the motorcycle to malfunction.

Weather, terrain and geographical location affect maintenance. The maintenance schedule should be adjusted to match the particular environment in which the motorcycle is used and the demands of the individual owner.

Special tools, knowledge and training are required in order to correctly carry out the maintenance items listed in the scheduled maintenance chart. An authorized Triumph dealer will have the necessary knowledge, equipment, and skills to maintain your Triumph motorcycle correctly.

WARNING Continued

Scheduled maintenance must be carried out by a competent person with the specialist knowledge and technical understanding of motorcycles, such as an authorized Triumph dealer.

Incorrect or neglected maintenance may lead to a dangerous riding condition, leading to loss of motorcycle control which could result in serious injury or death.

To maintain the motorcycle in a safe and reliable condition, the maintenance and adjustments outlined in this section must be carried out as specified in the schedule of daily checks, and also in line with the scheduled maintenance chart. The information that follows describes the procedures to follow when carrying out the daily checks and some simple maintenance and adjustment items.

Scheduled maintenance may be carried out in three ways; annual maintenance, mileage based maintenance or a combination of both, depending on the mileage the motorcycle travels each year.

- ▼ Motorcycles traveling less than 10,000 miles (16,000 km) per year must be maintained annually. In addition to this, mileage based items require maintenance at their specified intervals, as the motorcycle reaches this mileage.
- ▼ Motorcycles traveling approximately 10,000 miles (16,000 km) per year must have the annual maintenance and the specified mileage based items carried out together.

MAINTENANCE AND ADJUSTMENT

- ▼ Motorcycles traveling more than 10,000 miles (16,000 km) per year must have the mileage based items maintained as the motorcycle reaches the specified mileage. In addition to this, annual based items will require maintenance at their specified annual intervals.

In all cases maintenance must be carried out at or before the specified maintenance intervals shown. For advice on which maintenance schedule is most suitable for your motorcycle, contact a competent person with the specialist knowledge and technical understanding of motorcycles, such as an authorized Triumph dealer.

Triumph Motorcycles cannot accept any responsibility for damage or injury resulting from incorrect maintenance or improper adjustment.

Service Symbol/General Warning Symbol

The service symbol will illuminate for five seconds after the motorcycle start up sequence as a reminder that a service is due in approximately 62 miles (100 km). The service symbol will illuminate permanently when the mileage is reached, it will remain permanently illuminated until the service interval is reset. We recommend the service interval is reset by a competent person with the specialist knowledge and technical understanding of motorcycles, such as an authorized Triumph dealer.

The general warning symbol will flash if an ABS or engine management fault has occurred and the ABS and/or MIL warning lights are illuminated. The fault must be checked and rectified by a competent person with the specialist knowledge and technical understanding of motorcycles, such as an authorized Triumph dealer.

NOTICE

Items marked * in the Scheduled Maintenance Table are subject to additional labor charge, above the cost and time allowance for the basic service, which includes time to check only.

Disposal of Used Fluids

To protect the environment, do not pour the following on the ground, down sewers, drains or into groundwater sources:

- ▼ Engine oil
- ▼ Coolant
- ▼ Fuel
- ▼ Clutch and brake fluid
- ▼ Front fork oil.

Do not place used oil filters in with the general waste.

If in doubt for the disposal of the above, contact your local authority.

Scheduled Maintenance Table

Operation description	Odometer Reading in Miles (km) or Time Period, whichever comes first					
		First Service	Annual Service	Mileage Based Service		
	Daily	600 Mile (1,000 km) or 6 Month Service	Year	10,000 and 30,000 Mile (16,000 and 48,000 km) Service	20,000 Mile (32,000 km) Service	40,000 Mile (64,000 km) Service
Lubrication						
Engine - check for leaks	*	*	*	*	*	*
Engine oil level - check and adjust	*					
Engine oil - replace		*	*	*	*	*
Engine oil filter - replace		*	*	*	*	*
Engine oil strainers - clean		*	*	*	*	*
Fuel System and Engine Management						
Fuel system - check for leaks	*	*	*	*	*	*
Fuel and evaporative system - check hoses for chafing, cracks or damage. Replace if necessary*			*	*	*	*
Airbox drain tube(s) - drain/clean			*	*	*	*
Fuel filter - replace					*	*
Throttle body plate (butterfly) - check/clean					*	*
Air filter - replace (replace more often if consistently riding in wet or dusty conditions)					*	*
Spark plugs - replace					*	*
Cooling System						
Cooling system - check for leaks	*	*	*	*	*	*
Coolant level - check/adjust	*	*	*	*	*	*
Cooling system - check coolant hoses for chafing, cracks or damage. Replace if necessary*			*	*	*	*
Coolant hoses - replace - every 4 years, regardless of mileage*	Every four years, regardless of mileage					
Coolant - replace - every 4 years, regardless of mileage*	Every four years, regardless of mileage					
Water pump seals - replace (30,000 miles (48,000 km) only)				*		
Engine						
Clutch - check operation	*	*	*	*	*	*
Clutch cable - check function and adjust/replace as necessary (models equipped with a cable clutch only)*	*	*	*	*	*	*
Clutch lever pivot - clean/grease			*	*	*	*
Valve clearances - check/adjust*					*	*
Wheels and Tires						
Wheels - inspect for damage	*	*	*	*	*	*
Tire wear/tire damage - check	*	*	*	*	*	*
Tire pressures - check/adjust	*	*	*	*	*	*
Wheel bearings - check for wear/smooth operation					*	*

MAINTENANCE AND ADJUSTMENT

Operation description	Odometer Reading in Miles (km) or Time Period, whichever comes first					
		First Service	Annual Service	Mileage Based Service		
	Daily	600 Mile (1,000 km) or 6 Month Service	Year	10,000 and 30,000 Mile (16,000 and 48,000 km) Service	20,000 Mile (32,000 km) Service	40,000 Mile (64,000 km) Service
Steering and Suspension						
Steering - check for free operation	*	*	*	*	*	*
Front and rear suspension - check for damage/leaks/smooth operation	*	*	*	*	*	*
Swinging arm spindle - lubricate				*	*	*
Headstock bearings - check/adjust - except first service					*	*
Fork oil - replace						*
Brakes						
Brake system - check operation	*	*	*	*	*	*
Brake pads - check wear levels*	*	*	*	*	*	*
Brake fluid levels - check	*	*	*	*	*	*
Brake fluid - replace - every 2 years, regardless of mileage*	Every two years, regardless of mileage					
Final Drive						
Drive chain slack - check/adjust	*	*	*	*	*	*
Drive chain - wear check*		*	*	*	*	*
Drive chain - lubricate		*	*	*	*	*
Drive chain rubbing strip - check for wear, cracks or damage*		*	*	*	*	*
Electrical						
Lights, instruments and electrical systems - check/adjust	*	*	*	*	*	*
General						
Bank angle indicators - check for wear*	*	*	*	*	*	*
Center and/or side stand - check for wear/smooth operation	*	*	*	*	*	*
Instruments and engine ECM - check for latest calibration download using the Triumph diagnostic tool		*	*	*	*	*
Autoscan - carry out a full Autoscan using the Triumph diagnostic tool (print a customer copy)		*	*	*	*	*
Fasteners - inspect visually for security		*	*	*	*	*
Carry out all outstanding Service Bulletin and warranty work		*	*	*	*	*
Carry out road test		*	*	*	*	*
Complete the service record book and reset the service indicator (if equipped)		*	*	*	*	*
Seat latch cable - check for smooth operation, lubricate as necessary		*	*	*	*	*

Engine Oil

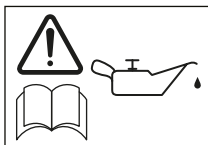

In order for the engine, transmission, and clutch to function correctly, maintain the engine oil at the correct level, and change the engine oil and oil filter in accordance with scheduled maintenance requirements.

Engine Oil Level Inspection

! DANGER

Never start the engine or run the engine in a confined area.

Always operate the motorcycle in the open air or in an area with adequate ventilation.

Exhaust fumes are poisonous and will cause loss of consciousness and death within a short period of time.

! WARNING

Make sure the motorcycle is stabilized and adequately supported.

Do not support the motorcycle on any ancillary component, the exhaust system or any other non structural parts of the motorcycle frame.

A correctly supported motorcycle will help prevent it from falling.

An unstable motorcycle may fall resulting in motorcycle damage, serious injury or death.

! WARNING

Make sure that the engine oil level is correct and the oil is changed in accordance with the scheduled maintenance requirements.

Motorcycle operation with insufficient, deteriorated, or contaminated engine oil will cause accelerated engine wear and may result in engine or transmission seizure.

Seizure of the engine or transmission may lead to sudden loss of motorcycle control which could result in serious injury or death.

! CAUTION

If the engine has recently been running, the exhaust components may be hot to the touch.

To avoid skin damage, always allow the hot parts to cool before touching the exhaust system.

Contact with the hot components may cause minor to moderate injury to exposed skin.

NOTICE

If the engine oil pressure is too low, the low oil pressure warning light will illuminate.

If the low oil pressure indicator remains on, stop the engine immediately and investigate the situation.

Running the engine with low oil pressure will cause severe engine damage.

MAINTENANCE AND ADJUSTMENT

- ▼ Position the motorcycle on level ground and in an upright position. The sight glass can be viewed from the right hand side of the motorcycle, towards the rear of the engine.
- ▼ Start the engine and run at idle for approximately five minutes.
- ▼ Stop the engine, then wait for at least five minutes to allow the engine oil to settle.
- ▼ Note the engine oil level visible in the sight glass.
- ▼ When correct, engine oil should be visible in the sight glass at a point between the upper (maximum) and lower (minimum) markings on the sight glass.

- ▼ When the correct level is reached, install and tighten the engine oil filler plug.

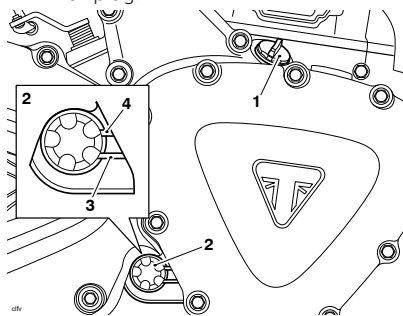

1. Engine oil filler plug
2. Sight glass
3. Lower marking (minimum)
4. Upper marking (maximum)

NOTICE

An accurate indication of the level of engine oil in the engine is only shown when the engine is at normal operating temperature and the motorcycle is upright (not on the side stand).

- ▼ If it is necessary to top off the oil level, remove the engine oil filler plug and using a suitable funnel, add oil, a little at a time, until the level registered in the sight glass is correct.

CAUTION

Make sure no contamination enters the engine during an engine oil change or top off.

Contamination entering the engine may lead to engine damage.

Engine Oil and Oil Filter Change

WARNING

Always wear suitable protective clothing and avoid skin contact with used engine oil.

Prolonged or repeated contact with engine oil can lead to skin dryness, irritation and dermatitis.

Used engine oil contains harmful contamination that can lead to skin cancer.

Failure to follow the advice above could result in serious injury or death.

⚠ CAUTION

The engine oil may be hot.

Avoid contact with the hot engine oil by wearing suitable protective clothing, gloves and eye protection.

Contact with the hot engine oil may cause minor to moderate injury to exposed skin.

⚠ CAUTION

If the engine has recently been running, the exhaust components may be hot to the touch.

To avoid skin damage, always allow the hot parts to cool before touching the exhaust system.

Contact with the hot components may cause minor to moderate injury to exposed skin.

The engine oil and engine oil filter must be replaced in accordance with scheduled maintenance requirements.

- ▼ Remove the two fasteners that attach the front left cover finisher and remove the finisher.

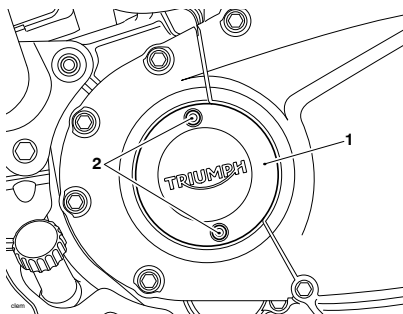

1. Front left cover finisher
2. Fasteners

- ▼ Remove the fasteners that attach the front left engine cover and remove the cover.

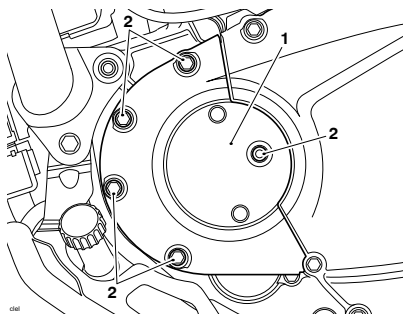

1. Front left engine cover
2. Fasteners

Engine Oil Strainer

- ▼ Warm up the engine thoroughly and stop the engine.
- ▼ Position the motorcycle on level ground and in an upright position.
- ▼ Place an oil drain pan beneath the engine.
- ▼ Remove the engine oil drain plug and discard the O-ring.
- ▼ Drain the engine oil.
- ▼ Remove the engine oil strainer.
- ▼ Clean the engine oil drain plug and install a new O-ring.

MAINTENANCE AND ADJUSTMENT

- ▼ Clean the engine oil strainer.

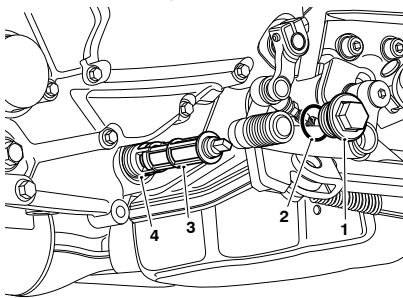

1. Engine oil drain plug
2. Engine oil drain plug O-ring
3. Engine oil strainer
4. Engine oil strainer O-ring

Evacuation Strainer

- ▼ Remove the evacuation strainer plug with the evacuation strainer.
- ▼ Allow the engine oil to drain.
- ▼ Pull the plug from the evacuation strainer and discard the O-ring.
- ▼ Clean the evacuation strainer and evacuation strainer plug. Install a new O-ring on the plug.
- ▼ Install the evacuation strainer

- ▼ Install and tighten the evacuation strainer plug to 89 lbf in (10 Nm).

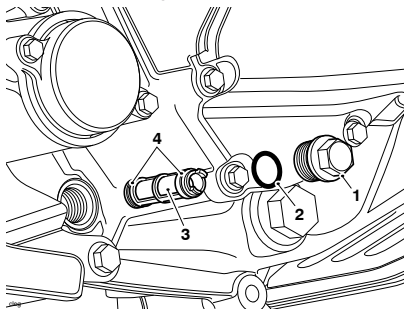

1. Evacuation strainer plug
2. Evacuation strainer plug O-ring
3. Evacuation strainer
4. Evacuation strainer O-rings

Engine Oil Filter

- ▼ Remove the fasteners from the engine oil filter cover.
- ▼ Remove the cover and discard the O-ring.
- ▼ Using a suitable tool, remove the engine oil filter. Dispose of the old oil and oil filter in an environmentally friendly way.
- ▼ Dip the engine oil filter in clean engine oil before installation.
- ▼ Install a new O-ring on the cover.

- ▼ Install the engine oil filter and cover, and tighten the fasteners to 8 lbf ft (11 Nm).

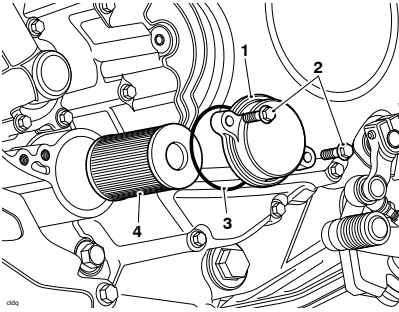

1. Engine oil filter cover
2. Engine oil filter cover fasteners
3. Engine oil filter cover O-ring
4. Engine oil filter

- ▼ Install the engine oil strainer.
- ▼ Install and tighten the engine oil drain plug to 10 lbf ft (13 Nm).

Engine Oil Filling

- ▼ Remove the engine oil filler plug.
- ▼ Using a suitable funnel, fill the engine with a fully synthetic 10W/50 motorcycle engine oil which meets specification API SN (or higher) and JASO MA2. Semi synthetic engine oil must not be used. Triumph Performance fully synthetic engine oil is recommended.

NOTICE

The engine oil grade specified must be used.

Using the incorrect engine oil grade may result in engine damage.

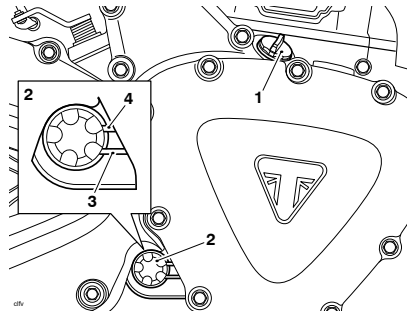

1. Engine oil filler plug
2. Sight glass
3. Lower marking (minimum)
4. Upper marking (maximum)

- ▼ Start the engine and allow it to idle for a minimum of 30 seconds.

NOTICE

Raising the engine speed above idle before the oil reaches all parts of the engine can cause engine damage or seizure.

Only raise engine speed after running the engine for 30 seconds to allow the oil to circulate fully.

- ▼ Make sure that the low oil pressure warning light remains off.

NOTICE

If the engine oil pressure is too low, the low oil pressure warning light will illuminate.

If the low oil pressure indicator remains on, stop the engine immediately and investigate the situation.

Running the engine with low oil pressure will cause severe engine damage.

- ▼ Stop the engine, then wait for at least five minutes to allow the engine oil to settle.
- ▼ Recheck the engine oil level. Adjust if necessary, see page 89.
- ▼ Position the front left engine cover and install the fasteners. Tighten to 8 lbf ft (11 Nm).

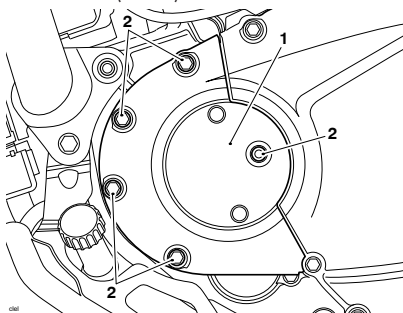

1. Front left engine cover
2. Fasteners

- ▼ Position the front left cover finisher and install the two fasteners. Tighten to 62 lbf in (7 Nm).

Engine Oil Specification and Grade (10W/50)

Triumph's high performance fuel injected engines are designed to use fully synthetic 10W/50 motorcycle engine oil which meets specification API SN (or higher) and JASO MA2. Semi synthetic engine oil must not be used. Triumph Performance fully synthetic engine oil is recommended.

NOTICE

The engine oil grade specified must be used.

Using the incorrect engine oil grade may result in engine damage.

Do not add any chemical additives to the engine oil. The engine oil also lubricates the clutch and any additives could cause the clutch to slip.

Do not use mineral, vegetable, non-detergent oil, castor based oils or any oil not conforming to the required specification. The use of these oils may cause instant, severe engine damage.

Make sure that no foreign matter enters the crankcase during an engine oil change or top off.

Cooling System



To ensure efficient engine cooling, check the coolant level each day before riding the motorcycle, and top off the coolant if the level is low.

NOTICE

The motorcycle is filled with a year round, Organic Additive Technology (known as OAT) coolant when it leaves the factory. It is colored orange or green, and contains a 50% solution of mono-ethylene glycol based antifreeze.

Triumph D2053 OAT coolant (premixed) is colored orange.

HP THANDA RAJA B OAT coolant is colored green.

These premixed coolants provide freeze protection to at least -29°F (-34°C).

Do not mix coolants of different types and colors. Mixing coolants of different types will reduce the performance of the coolant and reduce its life. When replacing coolant, it is recommended to thoroughly flush the cooling system with clean water.

Corrosion Inhibitors

⚠ WARNING

Coolant contains corrosion inhibitors and antifreeze suitable for aluminum engines and radiators. Always use the coolant in accordance with the instructions of the manufacturer.

Coolant contains toxic chemicals that are harmful to the human body.

Contact with skin or eyes may cause severe irritation. Wear protective gloves, clothing and eye protection when handling coolant.

If coolant is inhaled, remove the person to fresh air and keep comfortable for breathing. In case of doubt or persistent symptoms, seek medical attention.

If coolant gets on your skin, flush with water immediately. Remove contaminated clothing.

If coolant gets in your eyes, flush with water for at least 15 minutes and SEEK MEDICAL ATTENTION IMMEDIATELY.

If coolant is swallowed, rinse the mouth with water and SEEK MEDICAL ATTENTION IMMEDIATELY.

KEEP COOLANT OUT OF THE REACH OF CHILDREN.

NOTICE

Coolant, as supplied by Triumph, is premixed and does not need to be diluted prior to filling or topping off the cooling system.

To protect the cooling system from corrosion, the use of corrosion inhibitor chemicals in the coolant is essential.

MAINTENANCE AND ADJUSTMENT

If coolant containing a corrosion inhibitor is not used, the cooling system will accumulate rust and scale in the water jacket and radiator. This will block the coolant passages, and considerably reduce the efficiency of the cooling system.

Do not mix coolants of different types and colors. Mixing coolants of different types will reduce the performance of the coolant and reduce its life. When replacing coolant, it is recommended to thoroughly flush the cooling system with clean water.

Coolant Level Inspection

NOTICE

The coolant level should be checked when the engine is cold (at room or ambient temperature).

- ▼ Position the motorcycle on level ground and in an upright position. The expansion tank can be viewed from the left hand side of the motorcycle, towards the front and below the engine.

- ▼ Check the coolant level in the expansion tank. The coolant level must be between the MAX and MIN marks.

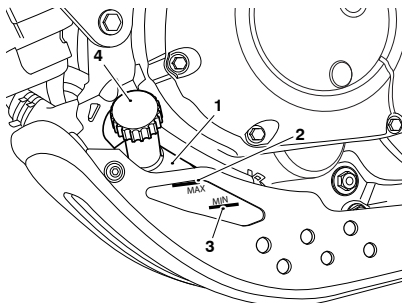

408

1. Expansion tank (Scrambler 400 X shown)
2. MAX mark
3. MIN mark
4. Expansion tank cap

- ▼ If the coolant is below the minimum level, the coolant level must be adjusted, see page 96.

Coolant Level Adjustment

CAUTION

Do not remove the radiator pressure cap when the engine is hot.

When the engine is hot, the coolant inside the radiator will be hot and also under pressure.

Contact with this hot, pressurized coolant may cause minor to moderate injury to exposed skin.

NOTICE

If hard water is used in the cooling system, it will cause scale accumulation in the engine and radiator and considerably reduce the efficiency of the cooling system.

Reduced cooling system efficiency may cause the engine to overheat and suffer severe damage.

- ▼ Allow the engine to cool.
- ▼ The expansion tank can be viewed from the left hand side of the motorcycle, towards the front and below the engine.
- ▼ Remove the cap from the expansion tank and add coolant mixture through the filler opening until the level reaches the MAX mark.
- ▼ Reinstall the cap.

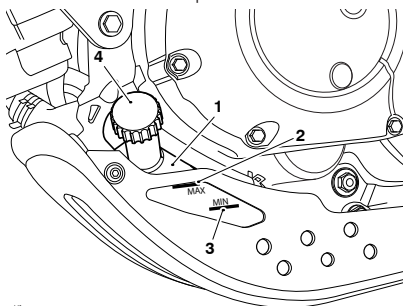

1. Expansion tank (Scrambler 400 X shown)
2. MAX mark
3. MIN mark
4. Expansion tank cap

NOTICE

If the coolant level is being checked because the coolant has overheated, also check the level in the radiator and top off if necessary.

In an emergency, distilled water can be added to the cooling system. However, the coolant must then be drained and replenished with the correct OAT coolant as soon as possible.

Coolant Change

⚠ CAUTION

The fan operates automatically when the engine is running.

Always keep hands and clothing away from the fan.

Contact with the rotating fan could result in minor to moderate injury.

NOTICE

Using high pressure water sprays, such as from a car wash facility or household pressure washer, can damage the radiator fins, cause leaks and impair the radiator's efficiency.

Do not obstruct or deflect airflow through the radiator by installing unauthorized accessories, either in front of the radiator or behind the cooling fan.

Interference with the radiator airflow can cause overheating, potentially resulting in engine damage.

We recommend that the coolant is changed in accordance with scheduled maintenance requirements.

MAINTENANCE AND ADJUSTMENT

Radiator and Hoses

CAUTION

The fan operates automatically when the engine is running.

Always keep hands and clothing away from the fan.

Contact with the rotating fan could result in minor to moderate injury.

NOTICE

Using high pressure water sprays, such as from a car wash facility or household pressure washer, can damage the radiator fins, cause leaks and impair the radiator's efficiency.

Do not obstruct or deflect airflow through the radiator by installing unauthorized accessories, either in front of the radiator or behind the cooling fan.

Interference with the radiator airflow can cause overheating, potentially resulting in engine damage.

Check the radiator hoses for cracks or deterioration, and tension clips for tightness in accordance with scheduled maintenance requirements. Any defective items must be replaced by a competent person with the specialist knowledge and technical understanding of motorcycles, such as an authorized Triumph dealer.

Check the radiator grille and fins for obstructions by insects, leaves or mud. Clean off any obstructions with a stream of low pressure water.

Throttle Control

WARNING

Always be alert for changes in the 'feel' of the throttle control. Changes can be due to wear in the mechanism, which could lead to a sticking or stuck throttle control.

If any changes are detected, the throttle system must be inspected by a competent person with the specialist knowledge and technical understanding of motorcycles, such as an authorized Triumph dealer.

A sticking or stuck throttle control may lead to loss of motorcycle control which could result in serious injury or death.

Throttle Inspection

WARNING

Use of the motorcycle with a sticking or damaged throttle control will interfere with the throttle function. The throttle may be difficult to control and performance will be affected.

To avoid continued use of a sticking or damaged throttle control, the throttle system must be inspected by a competent person with the specialist knowledge and technical understanding of motorcycles, such as an authorized Triumph dealer.

Failure to follow the advice above may lead to loss of motorcycle control which could result in serious injury or death.

- ▼ Check that the throttle opens smoothly, without undue force and that it closes quickly under its own return spring force without sticking and without manual intervention.
- ▼ Check that there is 0.04 - 0.08 in (1 - 2 mm) of throttle grip free play when lightly turning the throttle grip back and forth.
- ▼ If a problem is detected or any doubt exists, or if there is an incorrect amount of free play, the throttle system must be inspected by a competent person with the specialist knowledge and technical understanding of motorcycles, such as an authorized Triumph dealer.

Clutch

The motorcycle is equipped with a cable-operated clutch.

If the clutch lever has excessive free play, the clutch may not disengage fully. This will cause difficulty in shifting gear and selecting neutral. This may cause the engine to stall and make the motorcycle difficult to control.

Conversely, if the clutch lever has insufficient free play the clutch may not engage fully, causing the clutch to slip, which will reduce performance and cause premature clutch wear.

Clutch lever free play must be checked in accordance with scheduled maintenance requirements.

Clutch Inspection

- ▼ Check that there is 0.08 - 0.12 in clutch lever free play at the lever.
- ▼ If there is an incorrect amount of free play, adjustments must be made.

Clutch Cable Adjustment

- ▼ Loosen the lock nut at the clutch lever.
- ▼ Turn the adjuster sleeve to give 0.12 - 0.2 in (3.0 - 5.0 mm) in straight handlebar condition of free play.

MAINTENANCE AND ADJUSTMENT

- ▼ Tighten the lock nut.

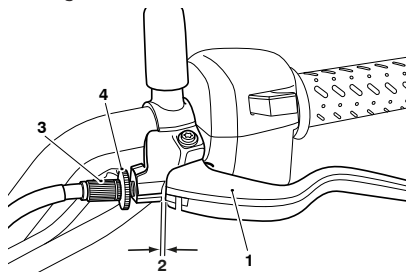

1. Clutch lever
2. Clearance
3. Adjuster sleeve
4. Adjuster lock nut

NOTICE

If correct adjustment cannot be made using the lever adjuster, use the cable adjuster at the lower end of the cable.

- ▼ If the clutch cable is loose, loosen the lock nut and turn the clutch cable adjuster clockwise to give 0.12 - 0.2 in (3.0 - 5.0 mm) in straight handlebar condition of free play at the clutch lever.
- ▼ If the clutch cable is tight, loosen the lock nut and turn the clutch cable adjuster counterclockwise to give 0.12 - 0.2 in (3.0 - 5.0 mm) in straight handlebar condition of free play at the clutch lever.

- ▼ Tighten the lock nut to 11 lbf ft (15 Nm).

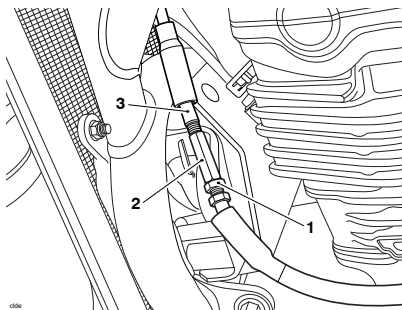

1. Adjuster lock nut
2. Clutch cable adjuster
3. Clutch outer cable

Drive Chain

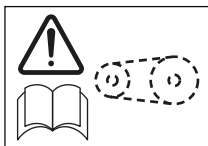

! DANGER

A loose or worn chain, or a chain that breaks or jumps off the sprockets could catch on the engine sprocket or lock the rear wheel.

A chain that snags on the engine sprocket or locking of the rear wheel will injure the rider.

Failure to follow the advice above will lead to loss of motorcycle control which will result in serious injury or death.

For safety and to prevent excessive wear the drive chain must be checked, adjusted and lubricated in accordance with scheduled maintenance requirements. Checking, adjustment and lubrication must be carried out more frequently for extreme conditions such as high speed riding, salty or heavily gritted roads.

If the chain is badly worn or incorrectly adjusted (either too loose or too tight) the chain could jump off the sprockets or break. Therefore, we recommend to always replace worn or damaged chains using genuine Triumph parts.

Drive Chain Lubrication

Lubrication is necessary every 200 miles (300 km) and also after riding in wet weather, on wet roads, or any time that the chain appears dry.

- ▼ Use the special drive chain lubricant as recommended in the Specifications section.
- ▼ Apply lubricant to the sides of the rollers then allow the motorcycle to stand unused for at least eight hours (overnight is ideal). This will allow the lubricant to penetrate to the drive chain O-rings etc.
- ▼ Before riding, wipe off any excess lubricant.
- ▼ If the drive chain is especially dirty, clean first and then apply lubricant as mentioned above.

NOTICE

Do not use a pressure washer to clean the drive chain as this may cause damage to the drive chain components.

MAINTENANCE AND ADJUSTMENT

Drive Chain Free Movement Inspection

⚠ WARNING

Make sure the motorcycle is stabilized and adequately supported.

Do not support the motorcycle on any ancillary component, the exhaust system or any other non structural parts of the motorcycle frame.

A correctly supported motorcycle will help prevent it from falling.

An unstable motorcycle may fall resulting in motorcycle damage, serious injury or death.

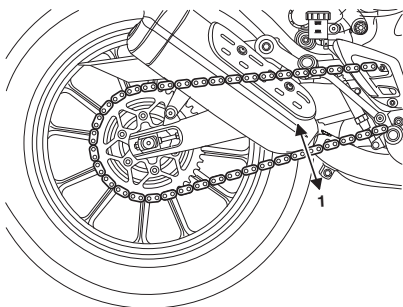

1. Maximum movement position (Scrambler 400 X shown)

- ▼ Position the motorcycle on level ground and in an upright position with no weight on it.
- ▼ Rotate the rear wheel by pushing the motorcycle to find the position where the drive chain is tightest, and measure the vertical movement of the chain midway between the sprockets.

- ▼ The vertical movement of the drive chain must be in the range of 0.79 - 0.98 in (20 - 25 mm) for Speed 400 and 1.57 - 1.77 in (40 - 45 mm) for Scrambler 400 X.
- ▼ If the measurement exceeds the range, then the drive chain needs to be adjusted, see page 102.

Drive Chain Free Movement Adjustment

If the drive chain free movement is incorrect, adjustments must be made as follows:

- ▼ Loosen the rear wheel spindle nut.
- ▼ Loosen the lock nuts on both the left hand and right hand chain adjuster bolts.
- ▼ Moving both adjusters by an equal amount, using the adjuster markings as a guideline, turn the adjuster bolts clockwise to increase drive chain free movement and counterclockwise to reduce drive chain free movement.
- ▼ When the drive chain free movement has been set to 0.79 - 0.98 in (20 - 25 mm) for Speed 400 and 1.57 - 1.77 in (40 - 45 mm) for Scrambler 400 X, see page 102, push the wheel into firm contact with the adjusters.
- ▼ Make sure the same adjuster marking is aligned with the spindle adjuster on both sides of the swinging arm.

- ▼ Tighten both adjuster lock nuts to 8 lbf ft (11 Nm) and the rear wheel spindle nut to 72 lbf ft (98 Nm).

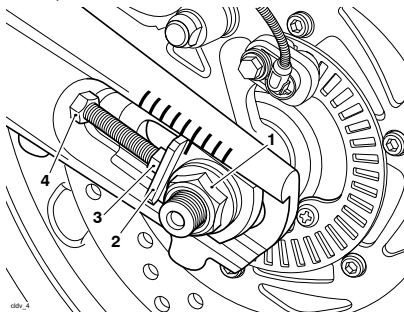

1. Rear wheel spindle nut (Scrambler 400 X shown)
2. Spindle adjuster
3. Adjuster bolt
4. Adjuster bolt lock nut

- ▼ Repeat the drive chain inspection. Readjust if necessary.

⚠ WARNING

When the drive chain adjustment is complete, make sure the wheel spindle and the adjuster lock nuts are tightened to the correct torque.

Operation of the motorcycle with a loose wheel spindle and/or loose adjuster lock nuts may affect the handling and stability.

Failure to follow the advice above may lead to loss of motorcycle control which could result in serious injury or death.

- ▼ Check the rear brake effectiveness. Rectify if necessary.

⚠ WARNING

It is dangerous to operate the motorcycle with defective brakes.

If a problem is detected or any doubt exists, the brakes must be inspected by a competent person with the specialist knowledge and technical understanding of motorcycles, such as an authorized Triumph dealer.

Operation of the motorcycle with defective brakes may lead to loss of motorcycle control which could result in serious injury or death.

Drive Chain and Sprocket Wear Inspection

⚠ WARNING

Make sure the motorcycle is stabilized and adequately supported.

Do not support the motorcycle on any ancillary component, the exhaust system or any other non structural parts of the motorcycle frame.

A correctly supported motorcycle will help prevent it from falling.

An unstable motorcycle may fall resulting in motorcycle damage, serious injury or death.

MAINTENANCE AND ADJUSTMENT

⚠ WARNING

Replacement drive chains must be installed by a competent person with the specialist knowledge and technical understanding of motorcycles, such as an authorized Triumph dealer.

We recommend to always replace worn or damaged chains using genuine Triumph parts.

Incorrectly installed drive chains may result in a broken drive chain or may cause the drive chain to jump off the sprockets, leading to loss of motorcycle control which could result in serious injury or death.

NOTICE

If the sprockets are found to be worn, always replace the sprockets and drive chain together.

Replacing worn sprockets without also replacing the drive chain will lead to premature wear of the new sprockets.

Remove the exhaust muffler, see Exhaust Secondary Muffler - Removal in the Service Manual.

- ▼ Loosen the two fasteners and remove the final drive chain guard.

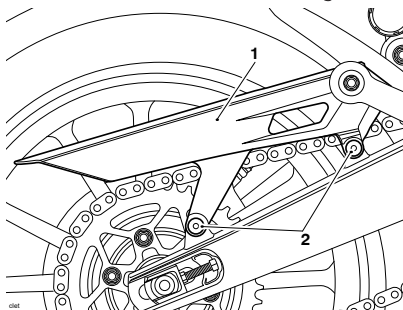

1. Final drive chain guard
2. Fasteners

Drive Chain Damage Inspection

⚠ WARNING

If the drive chain is found to have damaged rollers, loose pins or stiff links, the drive chain must be replaced.

Do not attempt to loosen any stiff links. The stiff link may have damaged or worn components.

Riding with drive chain stiff links, or loosened stiff links, may result in a broken drive chain or may cause the drive chain to jump off the sprockets, leading to loss of motorcycle control which could result in serious injury or death.

- ▼ Rotate the rear wheel and inspect the drive chain for damaged rollers, loose pins and stiff links.

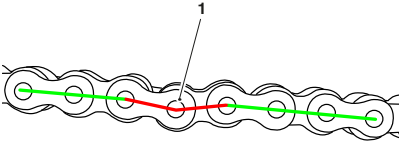

1. Stiff link

- ▼ If the drive chain has any damaged rollers, loose pins or stiff links, the drive chain must be replaced by a competent person with the specialist knowledge and technical understanding of motorcycles, such as an authorized Triumph dealer.

Drive Chain Wear Inspection

- ▼ Stretch the drive chain taut by hanging a 20 - 40 lb (10 - 20 kg) weight on the drive chain.

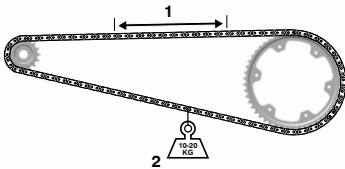

1. Measure across 20 links
2. Weight

- ▼ Measure the length of 20 links on the straight part of the drive chain from pin center of the 1st pin to the pin center of the 21st pin. Since the drive chain may wear unevenly, take measurements in several places.
- ▼ If the length exceeds the maximum service limit, the drive chain must be replaced. Refer to the Specifications section for the maximum service limit.

Sprockets Wear Inspection

NOTICE
<p>The illustration shows wear on sprockets mounted on the left hand side of the motorcycle.</p> <p>For sprockets mounted on the right hand side of the motorcycle, the wear is on the opposite side of the tooth.</p>

- ▼ Rotate the rear wheel and inspect the sprockets for unevenly or excessively worn or damaged teeth.

Worn Tooth
(Engine Sprocket)
Worn Tooth
(Rear Sprocket)

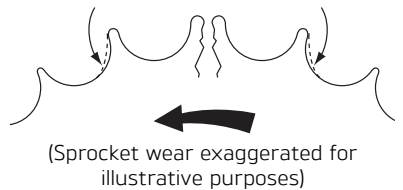

- ▼ If there is any wear or damage, the drive chain and the sprockets must be replaced by a competent person with the specialist knowledge and technical understanding of motorcycles, such as an authorized Triumph dealer.

- ▼ Install the final drive chain guard and tighten the fasteners to 80 lbf in (9 Nm).

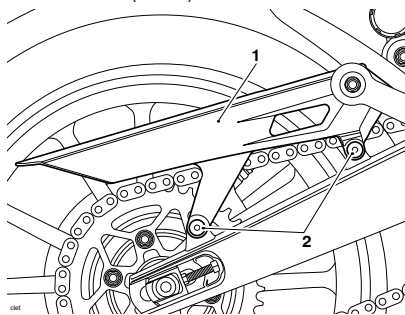

1. Final drive chain guard
2. Fasteners

Install the exhaust muffler, see Exhaust Secondary Muffler - Installation in the Service Manual.

Brakes

Front Brake Wear Inspection

WARNING

The use of proprietary brands of brake pads is not recommended as these may have a reduced carrier plate thickness when compared with the Triumph genuine parts.

Brake pads with an incorrect carrier plate thickness can potentially become dislodged from the caliper body as they wear, leading to brake failure, loss of motorcycle control and an accident.

Failure to follow the advice above could result in serious injury or death.

Brake pads must be inspected in accordance with scheduled requirements and replaced if worn to, or beyond the minimum service thickness.

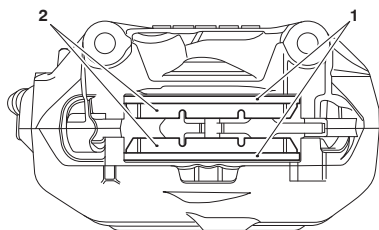

1. Carrier plates (Speed 400 shown)
2. Brake pads

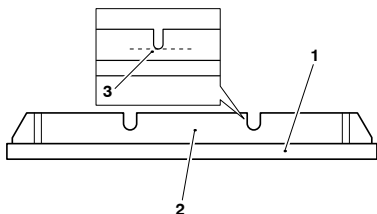

1. Carrier plate (Speed 400 shown)
2. Brake pad lining
3. Minimum thickness line

Brake pads for this model supplied by Triumph will have the carrier plate at the recommended thickness. We recommend that the brake pads are changed by a competent person with the specialist knowledge and technical understanding of motorcycles, such as an authorized Triumph dealer.

If the lining thickness of any brake pad is less than that specified in the table, replace all the brake pads on the wheel.

	Speed 400	Scrambler 400 X
Carrier plate thickness	0.138 in (3.5 mm)	0.147 in (3.74 mm)
Front brake pad lining minimum thickness	0.0394 in (1 mm)	0.0197 in (0.5 mm)
Minimum service thickness (Brake pad lining and carrier plate)	0.18 in (4.5 mm)	-
Minimum service thickness (Brake pad lining, carrier plate and shim)	-	0.167 in (4.24 mm)

Breaking-in New Brake Discs and Pads

WARNING

Brake pads must always be replaced as a wheel set. At the front, replace all the brake pads in the caliper.

After replacement brake pads have been installed, ride with extreme caution until the new pads have 'broken in'.

Replacing individual pads will reduce braking efficiency and may lead to loss of motorcycle control which could result in serious injury or death.

MAINTENANCE AND ADJUSTMENT

New brake discs and pads require a period of careful breaking-in that will optimize the performance and longevity of the discs and pads.

The recommended distance for breaking-in new pads and discs is 200 miles (300 km).

During the breaking-in period, avoid extreme braking, ride with caution and allow for greater braking distances.

Brake Pad Wear Compensation

⚠ WARNING

If the brake lever or pedal feels soft when it is applied, or if the lever/pedal travel becomes excessive, there may be air in the brake lines and hoses or the brakes may be defective.

The fault must be checked and rectified by a competent person with the specialist knowledge and technical understanding of motorcycles, such as an authorized Triumph dealer.

Riding with defective brakes may lead to a dangerous riding condition, leading to loss of motorcycle control which could result in serious injury or death.

Disc and brake pad wear is automatically compensated for and has no effect on the brake lever or pedal action. There are no parts that require adjustment on the front and rear brakes.

Rear Brake Wear Inspection

⚠ WARNING

The use of proprietary brands of brake pads is not recommended as these may have a reduced carrier plate thickness when compared with the Triumph genuine parts.

Brake pads with an incorrect carrier plate thickness can potentially become dislodged from the caliper body as they wear, leading to brake failure, loss of motorcycle control and an accident.

Failure to follow the advice above could result in serious injury or death.

Brake pads must be inspected in accordance with scheduled requirements and replaced if worn to, or beyond the minimum service thickness.

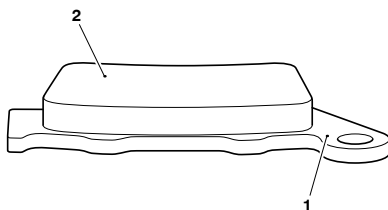

- div
1. Carrier plate
 2. Brake pad

Brake pads for this model supplied by Triumph will have the carrier plate at the recommended thickness. We recommend that the brake pads are changed by a competent person with the specialist knowledge and technical understanding of motorcycles, such as an authorized Triumph dealer.

If the lining thickness of any brake pad is less than that specified in the table, replace all the brake pads on the wheel.

All Models	
Carrier plate thickness	0.12 in (3.0 mm)
Rear brake pad lining minimum thickness	0.031 in (0.8 mm)
Minimum service thickness (Brake pad lining and carrier plate)	0.15 in (3.8 mm)

Disc Brake Fluid

WARNING

Brake fluid is hygroscopic which means it will absorb moisture from the air.

Any absorbed moisture will greatly reduce the boiling point of the brake fluid causing a reduction in braking efficiency.

Because of this, always replace brake fluid in accordance with scheduled maintenance requirements.

Always use new brake fluid from a sealed container and never use fluid from an unsealed container or from one which has been previously opened.

Do not mix different brands or grades of brake fluid.

Check for fluid leakage around brake installed, seals and joints and also check the brake hoses for splits, deterioration and damage.

Always rectify any faults before riding.

Failure to follow the advice above may lead to loss of motorcycle control which could result in serious injury or death.

WARNING

If the Anti-lock Brake System (ABS) is not functioning, the brake system will continue to function as a non-ABS equipped brake system. Reduce speed and do not continue to ride for longer than is necessary with the ABS warning light illuminated.

The fault must be checked and rectified by a competent person with the specialist knowledge and technical understanding of motorcycles, such as an authorized Triumph dealer.

Braking too hard will cause the wheels to lock, leading to loss of motorcycle control which could result in serious injury or death.

Inspect the level of brake fluid in both reservoirs and change the brake fluid in accordance with scheduled maintenance requirements. Use Triumph Performance DOT 4 brake fluid as recommended in the Specification section. The brake fluid must also be changed if it becomes, or is suspected of having become contaminated with moisture or any other contaminants.

MAINTENANCE AND ADJUSTMENT

Front Brake Fluid Level Inspection and Adjustment

⚠ WARNING

Make sure the motorcycle is stabilized and adequately supported.

Do not support the motorcycle on any ancillary component, the exhaust system or any other non structural parts of the motorcycle frame.

A correctly supported motorcycle will help prevent it from falling.

An unstable motorcycle may fall resulting in motorcycle damage, serious injury or death.

⚠ WARNING

If there has been an appreciable drop in the level of the fluid in either fluid reservoir the brake system must be inspected.

If the brake lever or pedal feels soft when it is applied, or if the lever/pedal travel becomes excessive, there may be air in the brake lines or the brake may be defective.

Riding with depleted brake fluid levels, or with a brake fluid leak is dangerous and will cause reduced brake performance

Contact a competent person with the specialist knowledge and technical understanding of motorcycles, such as an authorized Triumph dealer to inspect and, if necessary, repair the brake system.

Failure to follow the advice above may lead to loss of motorcycle control which could result in serious injury or death.

NOTICE

To prevent paint damage, do not spill brake fluid onto any area of the bodywork.

Spilled brake fluid will damage paintwork.

To inspect the front brake fluid level:

- ▼ Check the level of brake fluid visible in the window at the front of the reservoir.
- ▼ The brake fluid level must be kept between the MAX and MIN marks (reservoir held horizontal).

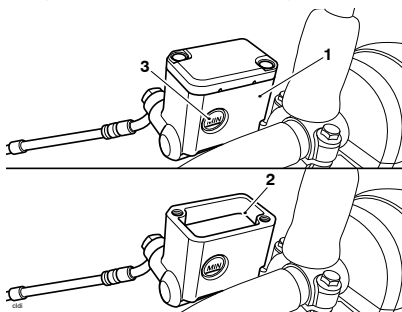

1. Reservoir (Scrambler 400 X shown)
2. MAX mark
3. MIN mark

To adjust the front brake fluid level:

- ▼ Loosen the reservoir cap retaining screws and remove the reservoir cap, and the plastic spacer and diaphragm seal.
- ▼ Fill the reservoir to the MAX mark using new DOT 4 brake fluid from a sealed container. Triumph Performance DOT 4 brake fluid is recommended.

- ▼ Reinstall the reservoir cap making sure that the plastic spacer and diaphragm seal is correctly positioned between the reservoir cap and the reservoir.

⚠ WARNING

Do not over tighten reservoir cap fasteners .

Over tightened reservoir cap fasteners may damage the brake fluid reservoir causing a brake fluid leak leading to reduced braking efficiency.

Failure to follow the advice above may lead to loss of motorcycle control which could result in serious injury or death.

- ▼ Tighten the reservoir cap retaining screws to 9 lbf in (1 Nm).

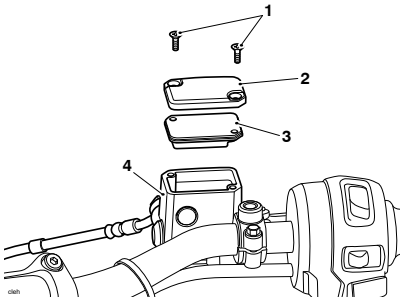

1. Reservoir cap retaining screws (Speed 400 shown)
2. Reservoir cap
3. Plastic spacer and diaphragm seal
4. Reservoir

Rear Brake Fluid Level Inspection and Adjustment

⚠ WARNING

Make sure the motorcycle is stabilized and adequately supported.

Do not support the motorcycle on any ancillary component, the exhaust system or any other non structural parts of the motorcycle frame.

A correctly supported motorcycle will help prevent it from falling.

An unstable motorcycle may fall resulting in motorcycle damage, serious injury or death.

⚠ WARNING

If there has been an appreciable drop in the level of the fluid in either fluid reservoir the brake system must be inspected.

If the brake lever or pedal feels soft when it is applied, or if the lever/pedal travel becomes excessive, there may be air in the brake lines or the brake may be defective.

Riding with depleted brake fluid levels, or with a brake fluid leak is dangerous and will cause reduced brake performance

Contact a competent person with the specialist knowledge and technical understanding of motorcycles, such as an authorized Triumph dealer to inspect and, if necessary, repair the brake system.

Failure to follow the advice above may lead to loss of motorcycle control which could result in serious injury or death.

NOTICE

To prevent paint damage, do not spill brake fluid onto any area of the bodywork.

Spilled brake fluid will damage paintwork.

The reservoir is visible from the right hand side of the motorcycle, forward of the muffler and below the seat.

To inspect the rear brake fluid level:

- ▼ Check the level of brake fluid visible in the reservoir.
- ▼ The brake fluid level must be kept between the MAX and MIN marks (reservoir held horizontal).

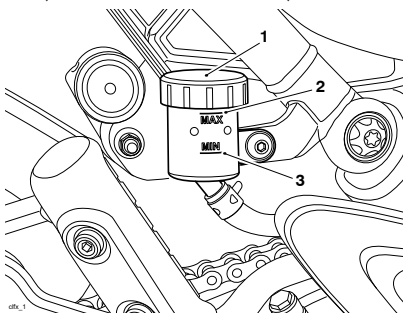

1. Reservoir
2. MAX mark
3. MIN mark

To adjust the rear brake fluid level:

- ▼ Remove the reservoir cap, and the plastic spacer and diaphragm seal.
- ▼ Fill the reservoir to the MAX mark using new DOT 4 brake fluid from a sealed container. Triumph Performance DOT 4 brake fluid is recommended.

- ▼ Reinstall the reservoir cap making sure that the plastic spacer and diaphragm seal is correctly positioned between the reservoir cap and the reservoir.

Brake Light Switches**WARNING**

Riding the motorcycle with defective brake lights is illegal and dangerous.

Before riding the motorcycle, make sure all lights are working.

Failure to follow the advice above could result in serious injury or death.

The brake light is activated independently by either the front or rear brake. If, with the ignition in the ON position, the brake light does not work when the front brake lever is pulled or the rear brake pedal is pressed, the fault must be checked and rectified by a competent person with the specialist knowledge and technical understanding of motorcycles, such as an authorized Triumph dealer.

Mirrors

WARNING

Always adjust the mirrors to provide sufficient rearward vision before riding the motorcycle.

Operation of the motorcycle with incorrectly adjusted mirrors is dangerous.

Operation of the motorcycle with incorrectly adjusted mirrors will result in loss of vision to the rear of the motorcycle. It is dangerous to ride a motorcycle without sufficient rearward vision.

Failure to follow the advice above could result in serious injury or death.

WARNING

Never attempt to clean or adjust mirrors while riding the motorcycle. Removal of the rider's hands from the handlebars while riding the motorcycle will diminish the ability of the rider to maintain control of the motorcycle.

Only attempt to clean or adjust the mirrors while stationary.

Attempting to clean or adjust mirrors while riding the motorcycle may lead to loss of motorcycle control which could result in serious injury or death.

Models with Bar End Mirrors

WARNING

Incorrect adjustment of the bar end mirrors may cause the mirror arm to contact the fuel tank, brake or clutch levers or other parts of the motorcycle.

This will restrict brake or clutch lever operation or restrict steering movement which may affect the handling, stability or other aspect of the motorcycle operation.

Adjust the mirrors as required to make sure they do not contact any part of the motorcycle. After adjustment, move the handlebar to the left and right full lock while checking that the mirrors do not contact the fuel tank, brake or clutch levers or other parts of the motorcycle.

Failure to follow the advice above may lead to loss of motorcycle control which could result in serious injury or death.

MAINTENANCE AND ADJUSTMENT

NOTICE

Incorrect adjustment of the bar end mirrors may cause the mirror arm to contact the fuel tank, brake or clutch levers or other parts of the motorcycle.

This will result in damage to the fuel tank, brake or clutch levers or other parts of the motorcycle.

Adjust the mirrors as required to make sure they do not contact any part of the motorcycle. After adjustment, move the handlebar to the left and right full lock while checking that the mirrors do not contact the fuel tank, brake or clutch levers or other parts of the motorcycle.

The bar end mirrors will be set by your authorized Triumph dealer and will not normally require any adjustment. Should adjustment be necessary, do not rotate the mirror beyond 75°, measured from the vertical section of the mirror arm.

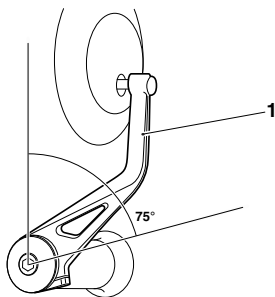

1. Mirror arm vertical section

Mirror Adjustment

⚠ WARNING

Make sure the motorcycle is stabilized and adequately supported.

Do not support the motorcycle on any ancillary component, the exhaust system or any other non structural parts of the motorcycle frame.

A correctly supported motorcycle will help prevent it from falling.

An unstable motorcycle may fall resulting in motorcycle damage, serious injury or death.

⚠ WARNING

If the mirror fastener is too loose, the mirror may blow back at speed.

Operation of the motorcycle with incorrectly adjusted mirrors will result in loss of vision to the rear of the motorcycle. It is dangerous to ride a motorcycle without sufficient rearward vision.

Failure to follow the advice above may lead to loss of motorcycle control which could result in serious injury or death.

NOTICE

The right mirror arm and lock nut has a left hand thread.

The left mirror arm and lock nut has a right hand thread.

- ▼ Lift the rubber cover to access the lock nut and mirror boss.

NOTICE

Use an open ended spanner to counter-hold the mirror boss as the mirror lock nut is loosened/tightened. Failure to counter-hold the boss will cause damage to the thread and the mirror to become loose.

- ▼ Counter-hold the mirror boss and loosen the mirror lock nut.
- ▼ Position the mirror arm to give rear visibility in the riding position and tighten the lock nut by hand.
- ▼ Counter-hold the mirror boss and tighten the mirror lock nut to 16.6 lbf ft (22.5 Nm).
- ▼ Slide the rubber cover over the lock nut.

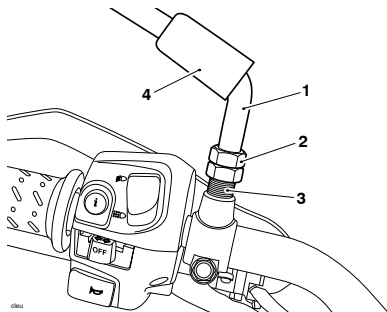

1. Mirror arm (Scrambler 400 X shown)
2. Lock nut
3. Mirror boss
4. Rubber cover

Steering/Wheel Bearings

⚠ WARNING

To prevent risk of injury from the motorcycle falling during the inspection, make sure that the motorcycle is stabilized and secured on a suitable support.

When inspecting steering and wheel bearings, do not exert extreme force against each wheel or rock each wheel vigorously as this may cause the motorcycle to become unstable and fall from its support.

Failure to follow the advice above could result in motorcycle damage, serious injury or death.

Steering Bearings Inspection

⚠ WARNING

Make sure the motorcycle is stabilized and adequately supported.

Do not support the motorcycle on any ancillary component, the exhaust system or any other non structural parts of the motorcycle frame.

A correctly supported motorcycle will help prevent it from falling.

An unstable motorcycle may fall resulting in motorcycle damage, serious injury or death.

MAINTENANCE AND ADJUSTMENT

⚠ WARNING

Never neglect steering (steering head) bearings maintenance. Check the steering bearings in accordance with scheduled maintenance requirements and make adjustments or replace as necessary.

Scheduled maintenance must be carried out by a competent person with the specialist knowledge and technical understanding of motorcycles, such as an authorized Triumph dealer.

Riding the motorcycle with incorrectly adjusted or defective steering bearings is dangerous and may lead to loss of motorcycle control which could result in serious injury or death.

The steering head bearings must be lubricated and inspected in accordance with scheduled maintenance requirements.

NOTICE

Always inspect the wheel bearings at the same time as the steering bearings.

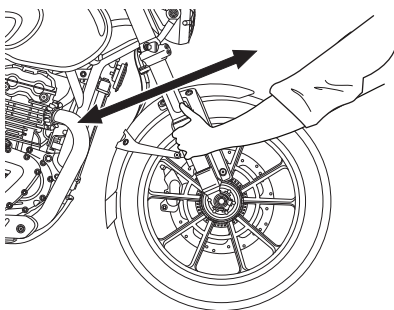

Inspecting the Steering for Free Play

- ▼ Position the motorcycle on level ground, in an upright position.
- ▼ Place the motorcycle on a suitable stand with the front wheel off the ground and secure the motorcycle.
- ▼ Standing at the front of the motorcycle, hold the lower end of the front forks and try to move them forward and backward.
- ▼ If any free play can be detected in the steering (steering head) bearings, the steering bearings must be inspected and adjusted by a competent person with the specialist knowledge and technical understanding of motorcycles, such as an authorized Triumph dealer.
- ▼ Remove the support and place the motorcycle on the side stand.

Wheel Bearings Inspection

⚠ WARNING

Make sure the motorcycle is stabilized and adequately supported.

Do not support the motorcycle on any ancillary component, the exhaust system or any other non structural parts of the motorcycle frame.

A correctly supported motorcycle will help prevent it from falling.

An unstable motorcycle may fall resulting in motorcycle damage, serious injury or death.

⚠ WARNING

Never neglect wheel bearings maintenance. Check the wheel bearings in accordance with scheduled maintenance requirements and make adjustments or replace as necessary.

Scheduled maintenance must be carried out by a competent person with the specialist knowledge and technical understanding of motorcycles, such as an authorized Triumph dealer.

Riding the motorcycle with worn or damaged wheel bearings is dangerous and may lead to loss of motorcycle control which could result in serious injury or death.

NOTICE

If the wheel bearings in the front or rear wheel allow play in the wheel hub, are noisy, or if the wheel does not turn smoothly, the wheel bearings must be inspected by a competent person with the specialist knowledge and technical understanding of motorcycles, such as an authorized Triumph dealer.

- ▼ Position the motorcycle on level ground, in an upright position.
- ▼ Place the motorcycle on a suitable stand with the front wheel off the ground and secure the motorcycle.
- ▼ Standing at the side of the motorcycle, gently rock the top of the front wheel from side to side.
- ▼ If any free play can be detected in the wheel bearings, the wheel bearings must be inspected and replaced by a competent person with the specialist knowledge and technical understanding of motorcycles, such as an authorized Triumph dealer.
- ▼ Reposition the suitable stand and repeat the procedure for the rear wheel.
- ▼ Remove the support and place the motorcycle on the side stand.

The wheel bearings must be inspected at the intervals specified in the scheduled maintenance chart.

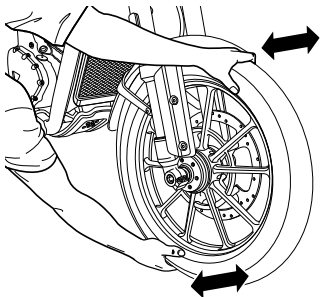

Inspecting the Wheel Bearings

MAINTENANCE AND ADJUSTMENT

Front Suspension

This motorcycle has no front suspension adjustment.

Front Fork Inspection

⚠ WARNING

Make sure the motorcycle is stabilized and adequately supported.

Do not support the motorcycle on any ancillary component, the exhaust system or any other non structural parts of the motorcycle frame.

A correctly supported motorcycle will help prevent it from falling.

An unstable motorcycle may fall resulting in motorcycle damage, serious injury or death.

⚠ WARNING

Never neglect front fork maintenance. Check the front forks in accordance with scheduled maintenance requirements and make adjustments or replace as necessary.

Scheduled maintenance must be carried out by a competent person with the specialist knowledge and technical understanding of motorcycles, such as an authorized Triumph dealer.

Riding with defective or damaged suspension components is dangerous and may lead to loss of motorcycle control which could result in serious injury or death.

⚠ CAUTION

All suspension units contain pressurized oil.

Do not attempt to dismantle any part of the suspension units. Inspections and repairs must be completed by a competent person with the specialist knowledge and technical understanding of motorcycles, such as an authorized Triumph dealer.

Accidental release of pressurized oil or springs could result in minor to moderate injury.

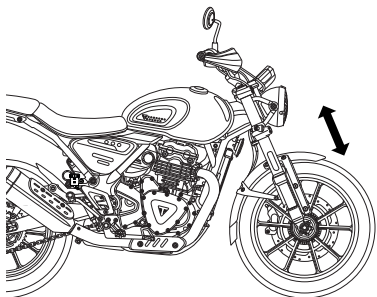

Scrambler 400 X Shown

- ▼ Position the motorcycle on level ground.
- ▼ While holding the handlebars and applying the front brake, pump the forks up and down several times.
- ▼ Check for roughness or excessive stiffness.
- ▼ Examine each fork for any sign of damage, scratching of the slider surface, or for oil leaks.

If a problem is detected or any doubt exists, the forks must be inspected by a competent person with the specialist knowledge and technical understanding of motorcycles, such as an authorized Triumph dealer.

Rear Suspension

Rear Suspension Settings

The motorcycle is delivered from the factory with all the suspension settings set at the Standard setting.

Refer to the following table or for further information contact a competent person with the specialist knowledge and technical understanding of motorcycles, such as an authorized Triumph dealer.

Rear Suspension Settings	
Loading	Spring Preload ¹
Solo Riding	1
Rider and Passenger	10
¹ Position 1 is minimum (fully clockwise) and position 10 is maximum (fully counterclockwise).	

The details shown in the table are only a guide. Setting requirements may vary for rider and passenger weight and personal preferences.

Rear Suspension Spring Preload Adjustment

The spring preload adjuster is located at the bottom of the rear suspension unit.

Rear adjuster settings are counted from one, with position one being with the adjuster turned fully clockwise. Position one gives the minimum amount of spring preload. There are ten adjuster positions in total. Position ten gives the maximum amount of spring preload.

- ▼ Insert the adjustment tool (supplied with the motorcycle) into the slots of the spring preload adjuster ring.

MAINTENANCE AND ADJUSTMENT

- ▼ Turn the spring preload adjuster ring counterclockwise to increase spring preload, and clockwise to decrease spring preload. When delivered from the factory, the preload adjuster will be set at position one.

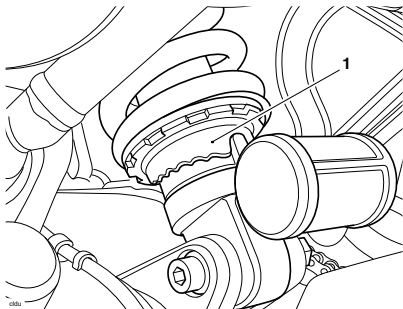

1. Spring preload adjuster ring

- ▼ Always count the number of counterclockwise turns from the fully clockwise position.

Bank Angle Indicators

⚠ WARNING

Always replace the bank angle indicators before they are worn to their maximum limit.

Use of a motorcycle with bank angle indicators worn beyond the maximum limit will allow the motorcycle to be banked to an unsafe angle.

Banking to an unsafe angle may lead to loss of motorcycle control which could result in serious injury or death.

Bank angle indicators are located on the rider's footrests.

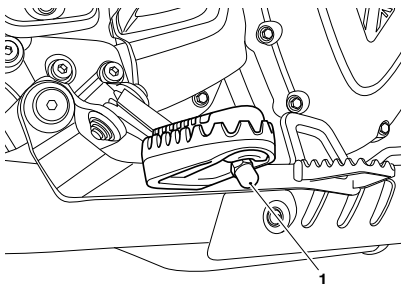

1. Bank angle indicator (Scrambler 400 X shown)

Bank angle indicators must be replaced when they have reached the maximum wear limit of 0.2 in (5 mm) in length.

Regularly check the bank angle indicators for wear.

Tires

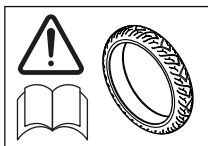

This model is equipped with tubeless tires, valves and wheel rims. Use only tires marked 'TUBELESS' and tubeless valves on rims marked 'SUITABLE FOR TUBELESS TIRES'.

! WARNING

Do not install tube type tires on tubeless rims. The bead will not seat and the tires could slip on the rims, causing rapid tire deflation.

Never install an inner tube inside a tubeless tire without the appropriate marking. This will cause friction inside the tire and the resulting heat build-up may cause the tube to burst resulting in rapid tire deflation.

Failure to follow the advice above may lead to loss of motorcycle control which could result in serious injury or death.

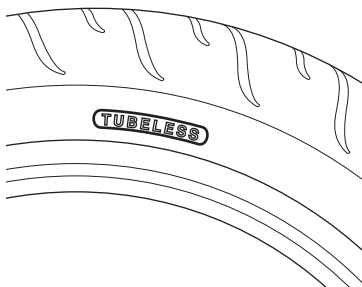

Typical Tire Marking - Tubeless Tire

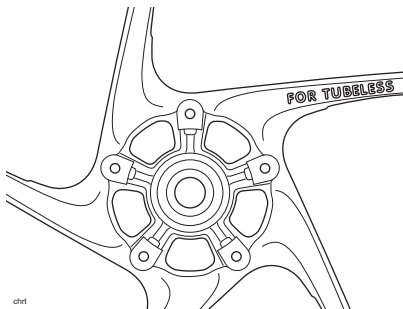

Typical Wheel Marking - Tubeless Tire

MAINTENANCE AND ADJUSTMENT

Tire Inflation Pressures

WARNING

Incorrect tire inflation will cause abnormal tread wear and instability problems.

Under inflation may result in the tire slipping on, or coming off the rim. Overinflation will cause instability and accelerated tread wear.

Both conditions are dangerous as they may lead to loss of motorcycle control which could result in serious injury or death.

WARNING

Tire pressures which have been reduced for off-road riding will impair on-road stability.

Always make sure that the tire pressures are set as described in the Specification section for on-road use.

Operation of the motorcycle with incorrect tire pressures may lead to loss of motorcycle control which could result in serious injury or death.

Correct inflation pressure will provide maximum stability, rider comfort and tire life. Always check tire pressures before riding when the tires are cold. Check tire pressures daily and adjust if necessary. See the Specification section for details of the correct inflation pressures.

Tire Wear

As the tire tread wears down, the tire becomes more susceptible to punctures and failure. It is estimated that 90% of all tire problems occur during the last 10% of tread life (90% worn). It is recommended that tires are changed before they are worn to their minimum tread depth.

Minimum Recommended Tread Depth

WARNING

Riding with damaged or defective wheels and/or excessively worn, punctured or damaged tires will affect traction, handling and stability.

When tubeless tires become punctured, leakage is often very slow. Always inspect tires very closely for punctures. Check the tires for cuts, embedded nails or other sharp objects. Check the wheel rims for dents or deformation.

For tire replacement or for a safety inspection of the tires, contact a competent person with the specialist knowledge and technical understanding of motorcycles, such as an authorized Triumph dealer.

Riding with damaged wheels and tires is dangerous and may lead to loss of motorcycle control which could result in serious injury or death.

In accordance with the periodic maintenance chart, measure the depth of the tread with a depth gage, and replace any tire that has worn to, or beyond the minimum allowable tread depth specified in the table below:

Under 80 mph (130 km/h)	0.08 in (2 mm)
Over 80 mph (130 km/h)	Front 0.08 in (2 mm) Rear 0.12 in (3 mm)

Tire Replacement

All Triumph motorcycles are carefully and extensively tested in a range of riding conditions to make sure that the most effective tire combinations are approved for use on each model.

It is essential that approved tires mounted in approved combinations, are used when purchasing replacement items.

The use of non-approved tires or approved tires in non-approved combinations, may lead to motorcycle instability, loss of control and an accident.

A list of approved tires specific to your motorcycle are available from your authorized Triumph dealer, or on the Internet at www.triumph.co.uk.

Tires must be selected in the correct combination, from the approved Tire Selector. Tires must be mounted and balanced according to the tire manufacturer's instructions.

When replacement tires are required, contact a competent person with the specialist knowledge and technical understanding of motorcycles, such as an authorized Triumph dealer.

Initially, the new tires will not produce the same handling characteristics as the worn tires and the rider must allow adequate riding distance (approximately 100 miles (160 km)) to become accustomed to the new handling characteristics.

The tire pressures must be checked and adjusted, and the tires examined for correct seating 24 hours after mounting. Rectification must be carried out as necessary. The same checks and adjustments must also be carried out when 100 miles (160 km) have been traveled after mounting.

WARNING

Use the recommended tires **ONLY** in the combinations listed in the approved Tire Selector at www.triumph.co.uk.

Do not mix tires from different manufacturers or mix different specification tires from the same manufacturers.

Using/mixing tires may affect the handling, stability, braking and traction control (if equipped) functions of the motorcycle.

Failure to follow the advice above may lead to loss of motorcycle control which could result in serious injury or death.

MAINTENANCE AND ADJUSTMENT

WARNING

Do not install tube type tires on tubeless rims. The bead will not seat and the tires could slip on the rims, causing rapid tire deflation.

Never install an inner tube inside a tubeless tire without the appropriate marking. This will cause friction inside the tire and the resulting heat build-up may cause the tube to burst resulting in rapid tire deflation.

Failure to follow the advice above may lead to loss of motorcycle control which could result in serious injury or death.

WARNING

If a tire sustains a puncture, the tire must be replaced.

Operation of the motorcycle with a punctured or repaired tire may adversely affect the motorcycle stability.

Failure to follow the advice above may lead to loss of motorcycle control which could result in serious injury or death.

WARNING

If tire damage is suspected, such as after striking an object, the tire must be inspected both internally and externally by a competent person with the specialist knowledge and technical understanding of motorcycles, such as an authorized Triumph dealer.

Tire damage may not always be visible from the outside.

Operation of the motorcycle with damaged tires may lead to loss of motorcycle control which could result in serious injury or death.

WARNING

Do not use the motorcycle with incorrectly seated tires or incorrectly adjusted tire pressures.

Incorrectly seated tires or incorrectly adjusted tire pressures may affect the handling, stability or other aspect of the motorcycle operation.

Failure to follow the advice above may lead to loss of motorcycle control which could result in serious injury or death.

! WARNING

ABS operates by comparing the relative speed of the front and rear wheels.

Use of non-recommended tires can affect wheel speed and cause the ABS function not to operate in conditions where the ABS would normally function.

A list of approved tires specific to these models is available from your authorized Triumph dealer, or on the Internet at www.triumph.co.uk.

Failure to follow the advice above may lead to loss of motorcycle control which could result in serious injury or death.

! WARNING

Tires that have been used on a rolling road dynamometer may become damaged. In some cases, the damage may not be visible on the external surface of the tire.

Tires must be replaced after such use as continued use of a damaged tire may cause instability.

Failure to follow the advice above may lead to loss of motorcycle control which could result in serious injury or death.

! WARNING

Accurate wheel balance is necessary for safe, stable handling of the motorcycle. Do not remove or change any wheel balance weights. Incorrect wheel balance may cause instability.

Only use self-adhesive weights. Clip on weights may damage the wheel or tire resulting in tire deflation.

When wheel balancing is required, such as after tire replacement, contact a competent person with the specialist knowledge and technical understanding of motorcycles, such as an authorized Triumph dealer.

Failure to follow the advice above may lead to loss of motorcycle control which could result in serious injury or death.

Battery

WARNING

The battery contains sulfuric acid (battery acid). Contact with skin or eyes may cause severe burns. Wear protective clothing and a face shield.

If battery acid gets on your skin, flush with water immediately.

If battery acid gets in your eyes, flush with water for at least 15 minutes and **SEEK MEDICAL ATTENTION IMMEDIATELY.**

If battery acid is swallowed, drink large quantities of water and **SEEK MEDICAL ATTENTION IMMEDIATELY.**

KEEP BATTERY ACID OUT OF THE REACH OF CHILDREN.

Failure to follow the advice above could result in serious injury or death.

WARNING

Make sure that there is adequate ventilation when charging or using the battery in an enclosed space.

Under certain circumstances, the battery may release explosive gases. Make sure to keep all sparks, flames and cigarettes away from the battery.

Do not attach jump leads to the battery, touch the battery cables together or reverse the polarity of the cables, as any of these actions may cause a spark which would ignite battery gases causing a risk of serious injury or death.

WARNING

The battery contains harmful materials.

Always keep children and pets away from the battery at all times.

Failure to follow the advice above could result in serious injury or death.

Battery - Removal

WARNING

Make sure the motorcycle is stabilized and adequately supported.

Do not support the motorcycle on any ancillary component, the exhaust system or any other non structural parts of the motorcycle frame.

A correctly supported motorcycle will help prevent it from falling.

An unstable motorcycle may fall resulting in motorcycle damage, serious injury or death.

WARNING

Make sure that the battery terminals do not touch the motorcycle frame.

This may cause a short circuit or spark which would ignite battery gases.

Failure to follow the advice above could result in serious injury or death.

WARNING

Before disconnecting the battery or removing a fuse for any reason, note and record the riding modes settings.

Once the fuse has been remounted or the battery reconnected, the riding modes should be reset as noted.

Failure to reset the motorcycle riding modes settings and subsequently being ridden, may cause loss of motorcycle control which could result in serious injury or death.

Speed 400

- ▼ Remove the seat, see page 57.

Scrambler 400 X

- ▼ Remove the rider and passenger seats, see page 57.

All Models

- ▼ Disconnect the battery negative (black) lead.

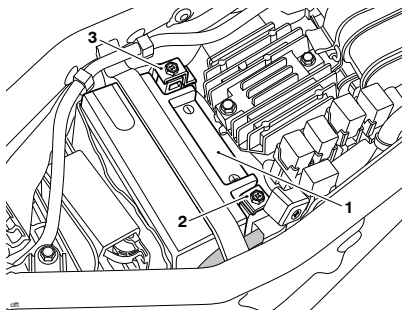

1. Battery
2. Positive (+) terminal
3. Negative (-) terminal

- ▼ Remove the positive (+) terminal protective cover to gain access to the fastener.

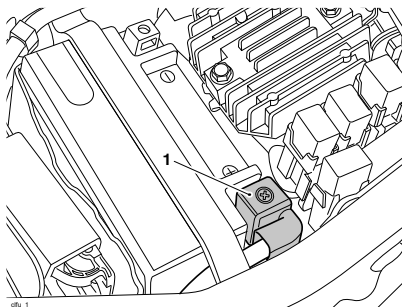

1. Positive (+) terminal cover

- ▼ Disconnect the battery positive (red) lead.
- ▼ Remove the battery strap.

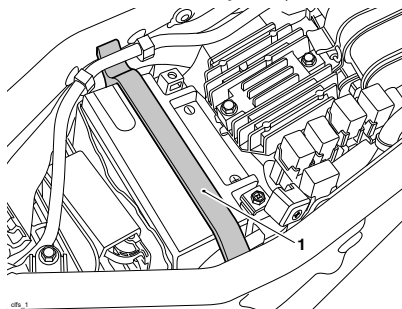

1. Battery strap

- ▼ Take the battery out of the case and remove from the battery sleeve.

Battery Disposal

Should the battery ever require replacement, the original battery must be handed to a recycling agent who will make sure that the dangerous substances from which the battery is manufactured do not pollute the environment.

MAINTENANCE AND ADJUSTMENT

Battery Maintenance

WARNING

Battery acid is corrosive and poisonous and will cause damage to unprotected skin.

Never swallow battery acid or allow it to come into contact with the skin.

To prevent injury, always wear eye and skin protection when handling the battery.

Failure to follow the advice above could result in serious injury or death.

The battery is a sealed type and does not require any maintenance other than checking the voltage and routine recharging when required, such as during storage.

Clean the battery using a clean, dry cloth. Make sure that the cable connections are clean.

It is not possible to adjust the battery acid level in the battery; the sealing strip must not be removed.

Battery Discharge

NOTICE

The charge level in the battery must be maintained to maximize battery life.

Failure to maintain the battery charge level could cause serious internal damage to the battery.

Under normal conditions, the motorcycle charging system will keep the battery fully charged. However, if the motorcycle is unused, the battery will gradually discharge due to a normal process called self discharge; the clock,

Engine Control Module (ECM) memory, high ambient temperatures, or the addition of electrical security systems or other electrical accessories will all increase this rate of battery discharge. Disconnecting the battery from the motorcycle during storage will reduce the rate of discharge.

Battery Discharge During Storage and Infrequent Use of the Motorcycle

During storage or infrequent use of the motorcycle, inspect the battery voltage weekly using a multimeter. Follow the manufacturer's instructions supplied with the meter.

Should the battery voltage fall below 12.7 Volts, the battery should be charged.

Allowing a battery to discharge or leaving it discharged for even a short period of time causes sulphation of the lead plates. Sulphation is a normal part of the chemical reaction inside the battery, however over time the sulphate can crystallize on the plates making recovery difficult or impossible. This permanent damage is not covered by the motorcycle warranty, as it is not due to a manufacturing defect.

Keeping the battery fully charged reduces the likelihood of it freezing in cold conditions. Allowing a battery to freeze will cause serious internal damage to the battery.

Battery Charging

WARNING

The battery contains sulfuric acid (battery acid). Contact with skin or eyes may cause severe burns. Wear protective clothing and a face shield.

If battery acid gets on your skin, flush with water immediately.

If battery acid gets in your eyes, flush with water for at least 15 minutes and **SEEK MEDICAL ATTENTION IMMEDIATELY.**

If battery acid is swallowed, drink large quantities of water and **SEEK MEDICAL ATTENTION IMMEDIATELY.**

KEEP BATTERY ACID OUT OF THE REACH OF CHILDREN.

Failure to follow the advice above could result in serious injury or death.

NOTICE

Do not use an automotive quick charger as it may overcharge and damage the battery.

For help with selecting a battery charger, checking the battery voltage or battery charging, contact a competent person with the specialist knowledge and technical understanding of motorcycles, such as an authorized Triumph dealer.

The Triumph recommended battery charger will come with a set of battery connector leads:

- ▼ A connector lead with ring terminals.
- ▼ A connector lead with crocodile clips.

A connector lead with a DIN plug is also available as an accessory from your Triumph dealer.

For extended periods of storage (beyond two weeks) the battery should be removed from the motorcycle and kept charged using a Triumph approved maintenance charger.

Similarly, should the battery charge fall to a level where it will not start the motorcycle, remove the battery from the motorcycle before charging.

Should the battery voltage fall below 12.7 Volts, the battery should be charged using a Triumph approved battery charger. Always remove the battery from the motorcycle.

To charge the battery, do the following:

- ▼ We recommend removing the battery from the motorcycle before charging.
 - If the battery needs to be charged when installed on the motorcycle, use the connector lead with ring terminals (supplied with the Triumph recommended battery charger).
 - Do not use the electrical accessory socket (if equipped). Charging the motorcycle battery using the electrical accessory socket may result in damage to the chassis control unit.
 - The connector lead with crocodile clips must not be used to charge the battery when it is mounted on the motorcycle.
- ▼ Follow the instructions supplied with the approved battery charger.
- ▼ Charge the battery with a lower current than the MAX Charging Current found on the charging label.

MAINTENANCE AND ADJUSTMENT

- ▼ If the battery becomes hot to the touch, stop charging and allow the battery to cool before resuming.
- ▼ After charging, leave the battery for 1 to 2 hours before checking the voltage. If the voltage is less than 12.9 Volts, additional charging is necessary.

Battery - Installation

⚠ WARNING

Make sure the motorcycle is stabilized and adequately supported.

Do not support the motorcycle on any ancillary component, the exhaust system or any other non structural parts of the motorcycle frame.

A correctly supported motorcycle will help prevent it from falling.

An unstable motorcycle may fall resulting in motorcycle damage, serious injury or death.

⚠ WARNING

Make sure that the battery terminals do not touch the motorcycle frame.

This may cause a short circuit or spark which would ignite battery gases.

Failure to follow the advice above could result in serious injury or death.

⚠ WARNING

If the battery has been disconnected or the fuses removed for any reason advise the rider to confirm the original mode settings have been correctly set. Failure to reset the motorcycle to the rider's preferred rider mode settings and subsequently being ridden may cause loss of motorcycle control and an accident.

- ▼ Place the battery in the battery sleeve and then in the battery case.
- ▼ Secure the battery into position with the battery strap.

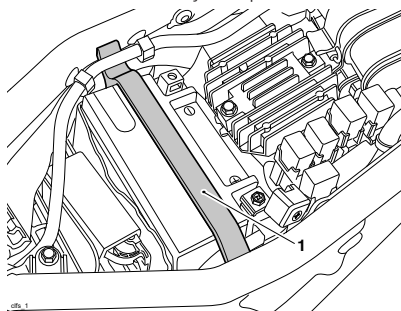

1. Battery strap

- ▼ Reconnect the battery, positive (red) lead first and then the negative (black) lead.
- ▼ Install and tighten the positive (+) terminal fastener to 40 lbf in (4.5 Nm).
- ▼ Install and tighten the negative (-) terminal fastener to 40 lbf in (4.5 Nm).
- ▼ Apply a light coat of grease to the battery terminals to prevent corrosion.

- ▼ Cover the positive (+) terminal with the protective cover.

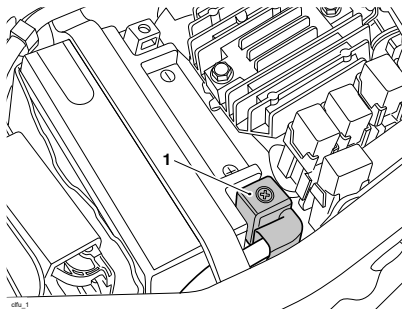

1. Positive (+) terminal cover

Speed 400

- ▼ Reinstall the seat, see page 58.

Scrambler 400 X

- ▼ Reinstall the rider and passenger seats, see page 58.

NOTICE

Once the fuse has been reinstalled or the battery reconnected the rider's settings should be reset as noted.

Fuses

WARNING

Always replace blown fuses with new ones of the correct rating (as specified on the fuse box cover).

Never replace a blown fuse with a fuse of a different rating.

Use of an incorrect fuse could lead to an electrical problem, resulting in motorcycle damage and leading to loss of motorcycle control which could result in serious injury or death.

NOTICE

A blown fuse is indicated when all of the systems protected by that fuse become inoperative. When checking for a blown fuse, use the table to establish which fuse has blown.

Fuse box 1 is located underneath the seat. To allow access to the fuse box, the seat for Speed 400 and the passenger seat for Scrambler 400 X must be removed, see page 57.

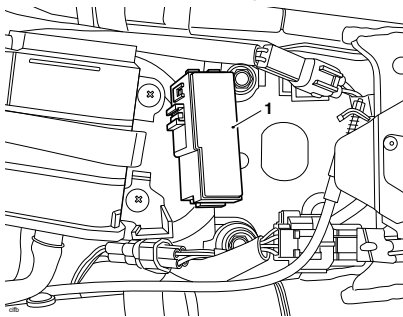

1. Fuse box 1

MAINTENANCE AND ADJUSTMENT

Fuse box 2 and the main fuse are located behind the left hand side panel. To allow access to the fuses, the side panel must be removed, see page 54.

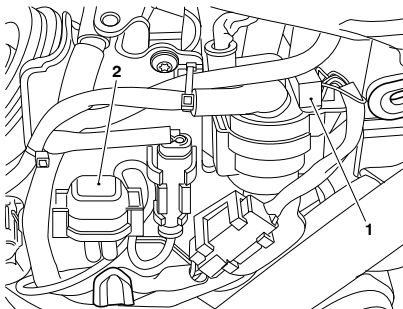

1. Main fuse (starter solenoid)
2. Fuse box 2

Fuse Identification

The fuse identification numbers listed in the tables correspond with those printed on the fuse box covers, as shown below.

Spare fuses for fuse box 1 are located on the inside of the fuse box and should be replaced if used.

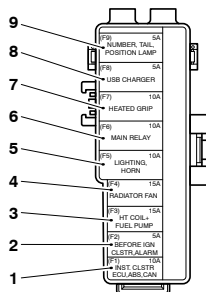

Fuse Box 1

Fuse Number and Circuit Protected	Rating (Amps)
Fuse 1 - Ignition supply to instruments, ABS, immobilizer, tracker unit	10
Fuse 2 - Battery supply to instruments, tracker unit	5
Fuse 3 - Ignition coil and fuel pump	15
Fuse 4 - Cooling fan	15
Fuse 5 - Headlight (dipped beam, high beam and DRL) and horn	10
Fuse 6 - Engine management system	10
Fuse 7 - Heated grips	10
Fuse 8 - USB socket	5
Fuse 9 - License plate light, brake/tail light and position light	5

Spare fuses for fuse box 2 are located on the inside of the fuse box and should be replaced if used.

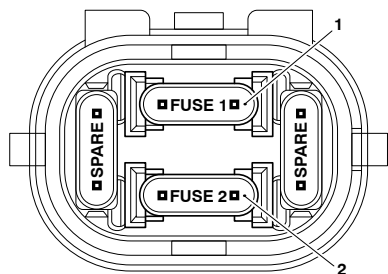

Fuse Box 2

Fuse Number and Circuit Protected	Rating (Amps)
Fuse 1 - ABS pump	15
Fuse 2 - ABS solenoid	10

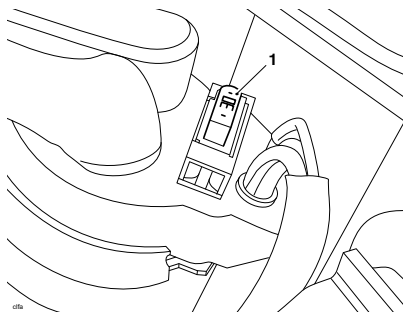

Main Fuse (Starter Solenoid)

Fuse Number and Circuit Protected	Rating (Amps)
Fuse 1 - Main fuse (battery supply to ignition key and other electrical loads)	30

Lights

NOTICE

The use of non-approved bulbs may result in damage to lenses and other lighting unit components.

In addition, the use of bulbs of incorrect wattage may cause the chassis ECM to cut power to affected lighting circuits.

Use genuine Triumph supplied bulbs as specified in the Triumph Parts Catalog.

Always have replacement bulbs installed by a competent person with the specialist knowledge and technical understanding of motorcycles, such as an authorized Triumph dealer.

Headlight(s)



WARNING

Adjust road speed to suit the visibility and weather conditions in which the motorcycle is being operated.

Make sure that the headlight beam is adjusted to illuminate the road surface sufficiently far ahead without blinding oncoming traffic.

An incorrectly adjusted headlight may impair visibility for oncoming traffic, leading to an accident which could result in serious injury or death.

MAINTENANCE AND ADJUSTMENT

WARNING

Never attempt to adjust a headlight beam when the motorcycle is in motion.

Any attempt to adjust a headlight beam when the motorcycle is in motion may lead to loss of motorcycle control.

Failure to follow the advice above could result in serious injury or death.

NOTICE

Do not cover the headlight or lens with any item likely to obstruct air flow to, or prevent heat escaping from, the headlight lens.

Covering the headlight lens during operation with items of clothing, luggage, adhesive tape, devices intended to alter or adjust the headlight beam or non genuine headlight lens covers will cause the headlight lens to overheat and distort, causing irreparable damage to the headlight assembly.

Damage caused by overheating is not considered a manufacturing defect and will not be covered under warranty.

If the headlight must be covered during use - such as taping of the headlight lens required during closed-course conditions - the headlight must be disconnected.

Condensation

In certain conditions, condensation may occur inside the headlight.

Condensation may happen while it is raining or after washing the motorcycle.

Condensation inside the headlight will gradually disappear with the headlight on while riding the motorcycle.

Time for evaporation will vary depending on the humidity of the ambient air.

NOTICE

If condensation inside the headlight does not clear, we recommend that the headlight is inspected by a competent person with the specialist knowledge and technical understanding of motorcycles, such as an authorized Triumph dealer.

Headlight Adjustment

NOTICE

Check and correct the tire pressures prior to adjusting the headlight.

- ▼ Make sure the handlebars are in the straight ahead position.
- ▼ Switch the headlight dipped beam on.
- ▼ Loosen the headlight mounting fasteners sufficiently to allow restricted movement of the headlight.
- ▼ Adjust the position of the headlight to give the required beam setting.

- ▼ Tighten the headlight mounting fasteners to 80 lbf in (9 Nm).

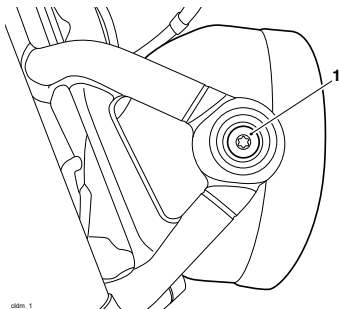

1. **Headlight mounting fastener (Scrambler 400 X shown)**

- ▼ Recheck the headlight beam setting. Rectify as required.

Headlight Replacement

The headlight unit is a sealed, maintenance-free LED unit. The headlight unit must be replaced in the event of the failure of the headlight.

Daytime Running Light (DRL) (if equipped)

The Daytime Running Light (DRL) is situated within the headlight assembly and is a sealed, maintenance-free LED unit. The headlight unit must be replaced in the event of the failure of the DRL.

Position Light

The position light unit is a sealed, maintenance-free LED unit.

Brake/Tail Light

The brake/tail light unit is a sealed, maintenance-free LED unit. The tail light unit must be replaced in the event of the failure of the tail light.

Turn Signal Lights

The turn signal light units are sealed, maintenance-free LED units. A turn signal light unit must be replaced in the event of the failure of the turn signal light.

License Plate Light

The license plate light unit is a sealed, maintenance-free LED unit. The license plate light unit must be replaced in the event of the failure of the license plate light.

This page intentionally left blank

Table of Contents

Cleaning.....	138
Preparation for Washing.....	138
Where to be Careful.....	139
Washing.....	139
After Washing.....	140
Gloss Paintwork Care.....	140
Matt Paintwork Care.....	140
Aluminum Items - not Lacquered or Painted.....	141
Chrome and Stainless Steel Care.....	141
Black Chrome Care.....	142
Exhaust System Care.....	142
Seat Care.....	143
Windshield Care (if equipped).....	143
Monsoon/Rainy Season Care.....	144
Storage.....	145

Cleaning

Frequent, regular cleaning is an essential part of the maintenance of your motorcycle. If regularly cleaned, the appearance will be preserved for many years.

Cleaning with cold water containing an automotive cleaner is essential at all times but particularly so after exposure to sea breezes, sea water, dusty or muddy roads and in winter when roads are treated for ice and snow.

Do not use household detergent, as the use of such products will lead to premature corrosion.

Although, under the terms of your motorcycle warranty, cover is provided against the corrosion of certain items, the owner is expected to observe this reasonable advice which will safeguard against corrosion and enhance the appearance of the motorcycle.

Preparation for Washing

Before washing, precautions must be taken to keep water off the following places.

Rear opening of the exhausts: Cover with a plastic bag secured with rubber bands.

Clutch and brake levers, switch housings on the handlebar: Cover with plastic bags.

Ignition switch and steering lock: Cover the keyhole (if applicable) with tape.

Remove any items of jewelry such as rings, watches, zips or belt buckles, which may scratch or otherwise damage painted or polished surfaces.

Use separate cleaning sponges or cleaning cloths for washing painted/polished surfaces and chassis areas. Chassis areas (such as wheels and under fenders) will be exposed to more abrasive road grime and dust, which may then scratch painted or polished surfaces, if the same sponge or cleaning cloths are used.

Where to be Careful

NOTICE

Do not use high pressure spray washers or steam cleaners.

Use of high pressure spray washers and steam cleaners may damage seals, and cause water and steam to be forced into bearings and other components causing premature wear from corrosion and loss of lubrication.

NOTICE

Do not spray any water at all near the air intake duct.

The air intake duct is located under the rider's seat, under the fuel tank or near the steering head.

Any water sprayed in this area could enter the airbox and engine, causing damage to both items.

Do not get water near the following places:

- ▼ Air and any intake duct
- ▼ Any visible electrical components
- ▼ Brake cylinders and brake calipers
- ▼ Handlebar switch housings
- ▼ Steering head bearings
- ▼ Instruments
- ▼ Oil filler cap
- ▼ Rear of headlights
- ▼ Seats
- ▼ Suspension seals and bearings
- ▼ Under the fuel tank
- ▼ Wheel bearings.

Washing

To wash the motorcycle, do the following:

- ▼ Make sure that the motorcycle engine is cold.
- ▼ Prepare a mixture of clean, cold water and mild automotive cleaner or low alkaline soap.
- ▼ Do not use a highly alkaline soap as commonly found at commercial car washes because it will leave a residue on painted surfaces and may also cause water spotting.
- ▼ Wash the motorcycle with a sponge or soft cloth.
- ▼ Do not use abrasive scouring pads or steel wool. They will damage the finish.
- ▼ Rinse the motorcycle thoroughly with clean, cold water.

After Washing

WARNING

Never wax or lubricate the brake discs.

Always clean the brake disc with a proprietary brand of oil-free brake disc cleaner.

Waxed or lubricated brake discs may lead to loss of motorcycle control which could result in serious injury or death.

After washing the motorcycle, do the following:

- ▼ Remove the plastic bags and tape, and clear the air intakes.
- ▼ Lubricate the pivots, bolts and nuts.
- ▼ Test the brakes before motorcycle operation.
- ▼ Use a dry cloth or chamois leather to absorb water residue. Do not allow water to stand on the motorcycle as this will lead to corrosion.
- ▼ Start the engine and run it for 5 minutes. Make sure that there is adequate ventilation for the exhaust fumes.

Gloss Paintwork Care

Gloss paintwork should be washed and dried as described previously, then protected using a high quality automotive wax polish. Always follow the manufacturer's instructions and repeat regularly to maintain your motorcycle's appearance.

Matt Paintwork Care

Matt paintwork requires no greater care than that already recommended for gloss paintwork.

- ▼ Do not use any polish or wax on matt paintwork.
- ▼ Do not try and polish out scratches.

Aluminum Items - not Lacquered or Painted

Items such as brake and clutch levers, wheels, engine covers, engine cooling fins, upper and lower yokes and throttle bodies on some models must be correctly cleaned to preserve their appearance. Please contact your dealer if you are unsure which components on your motorcycle are aluminum parts not protected by paint or lacquer, and for guidance on how to clean those items.

Use a proprietary brand of aluminum cleaner which does not contain abrasive or caustic elements.

Clean aluminum items regularly, in particular after use in inclement weather, where the components must be hand washed and dried each time the machine is used.

Warranty claims due to inadequate maintenance will not be allowed.

Chrome and Stainless Steel Care

All chrome and stainless steel parts of your motorcycle must be cleaned regularly to avoid a deterioration of its appearance.

Washing

Wash as previously described.

Drying

Dry the chrome and stainless steel parts as far as possible with a soft cloth or chamois leather.

Protecting

NOTICE

The use of products containing silicone will cause discoloration of the chrome and stainless steel parts and must not be used.

The use of abrasive cleaning products will damage the finish and must not be used.

When the chrome and stainless steel is dry, apply a suitable proprietary chrome cleaner on to the surface, following the manufacturer's instructions.

It is recommended that regular protection be applied to the motorcycle as this will both protect and enhance its appearance.

Black Chrome Care

Items such as headlight bowls and mirrors on some models must be correctly cleaned to preserve their appearance. Please contact your dealer if you are unsure which components on your motorcycle are black chrome parts. Maintain the appearance of black chrome items by rubbing a small amount of light oil into the surface.

Exhaust System Care

All parts of the exhaust system of your motorcycle must be cleaned regularly to avoid a deterioration of its appearance. These instructions can be applied to chrome, brushed stainless steel and carbon fiber components; matt painted exhaust systems should be cleaned as above, noting the care instructions in the Matt Paintwork section previously.

The exhaust system must be cool before washing to prevent water spotting.

Washing

Wash as previously described.

Make sure that no soap or water enters the exhausts.

Drying

Dry the exhaust system as far as possible with a soft cloth or chamois leather. Do not run the engine to dry the system or spotting will occur.

Protecting

NOTICE

The use of products containing silicone will cause discoloration of the chrome and stainless steel parts and must not be used.

The use of abrasive cleaning products will damage the finish and must not be used.

When the exhaust system is dry, apply a suitable proprietary motorcycle protection spray onto the surface, following the manufacturer's instructions.

It is recommended that regular protection be applied to the system as this will both protect and enhance the system's appearance.

CLEANING AND STORAGE

Seat Care

NOTICE

Do not use chemicals or high pressure spray washers to clean the seat.

Using chemicals or high pressure spray washers may damage the seat cover.

To help maintain its appearance, clean the seat using a sponge or cleaning cloth with soap and water.

Windshield Care (if equipped)

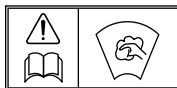

WARNING

Never attempt to clean the windshield while riding the motorcycle.

Removal of the rider's hands from the handlebars while riding the motorcycle will diminish the ability of the rider to maintain the control of the motorcycle.

Attempting to clean the windshield while riding the motorcycle may lead to loss of motorcycle control which could result in serious injury or death.

NOTICE

Corrosive chemicals such as battery acid will damage the windshield. Never allow corrosive chemicals to contact the windshield.

NOTICE

Products such as window cleaning fluids, insect remover, rain repellent, scouring compounds, gasoline or strong solvents such as alcohol, acetone, carbon tetrachloride, etc. will damage the windshield.

Never allow these products to contact the windshield.

Clean the windshield with a solution of mild soap or detergent and clean cold water.

After cleaning, rinse well and then dry with a soft, lint-free cloth.

If the transparency of the windshield is reduced by scratches or oxidation which cannot be removed, the windshield must be replaced.

Monsoon/Rainy Season Care

During the Monsoon/Rainy season, extra care is required in order to obtain consistent performance of your motorcycle.

Always observe the following:

- ▼ Make sure that the motorcycle is parked in a covered area. If a covered area is not available, then make sure to put a suitable waterproof breathable cover over the motorcycle.
- ▼ Make sure that the tires are in a good condition.
- ▼ Check and, if necessary, correct the tire pressures.
- ▼ The drive chain should be cleaned and lubricated every 200 miles (300 km) using Triumph Performance chain lubricant.

NOTICE

If the drive chain gets contaminated by mud, we recommend that the drive chain is cleaned and lubricated before riding.

- ▼ Check that the front and rear brakes are functioning correctly.

! WARNING

When using the motorcycle on loose, wet or muddy roads, braking effectiveness will be reduced by dust, mud or moisture collecting on the brakes.

Always brake earlier in these conditions to make sure that brake surfaces are cleaned by the braking action.

Riding the motorcycle with brakes contaminated with dust, mud or moisture may lead to loss of motorcycle control which could result in serious injury or death.

- ▼ Make sure that you wear appropriate waterproof clothing suitable for motorcycles.
- ▼ Never ride the motorcycle through floods as water may enter the engine. Water entering the engine may cause engine damage. Damage caused by water entering the engine is not covered by the motorcycle warranty, as it is not due to a manufacturing defect.
- ▼ If the motorcycle is parked and water level rises around the motorcycle, do not try to start the engine. The motorcycle should be inspected for water ingress before starting the engine. Inspections and repairs must be completed by a competent person with the specialist knowledge and technical understanding of motorcycles, such as an authorized Triumph dealer.

Storage**Preparation for Storage**

To prepare the motorcycle for storage, do the following:

- ▼ Clean and dry the entire vehicle thoroughly.
- ▼ Fill the fuel tank with the correct grade of unleaded fuel and add a suitable fuel stabilizer (if available), following the fuel stabilizer manufacturer's instructions.

! WARNING

Gasoline is extremely flammable and can be explosive under certain conditions.

If parking inside a garage or other structure, be sure it is well ventilated and the motorcycle is not close to any source of flame or sparks. This includes any appliance with a pilot light.

Failure to follow the above advice may cause a fire resulting in damage to property, serious injury or death.

- ▼ Remove the spark plug from the cylinder and put several drops (0.17 fl oz (5 ml)) of engine oil into the cylinder. Cover the spark plug holes with a piece of cloth or rag. With the engine stop switch in the RUN position, push the starter button for a few seconds to coat the cylinder walls with oil. Install the spark plug, tightening to 13 lbf ft (17 Nm).
- ▼ Change the engine oil and filter (see page 90).
- ▼ Check and if necessary correct the tire pressures (see page 122).

- ▼ Set the motorcycle on a stand so that both wheels are raised off the ground. (If this cannot be done, put boards under the front and rear wheels to keep dampness away from the tires.)
- ▼ Spray rust inhibiting oil (there are a host of products on the market and your dealer will be able to offer you local advice) on all unpainted metal surfaces to prevent rusting. Prevent oil from getting on rubber parts, brake discs or in the brake calipers.
- ▼ Make sure the cooling system is filled with a 50% mixture of coolant (noting that OAT coolant, as supplied by Triumph, is pre-mixed and requires no dilution) and distilled water solution (see page 95).
- ▼ Remove the battery, and store it where it will not be exposed to direct sunlight, moisture, or freezing temperatures. During storage it should be given a slow charge (one Ampere or less) about once every two weeks (see page 129).
- ▼ Store the motorcycle in a cool, dry area, away from sunlight, and with a minimum daily temperature variation.
- ▼ Put a suitable breathable cover over the motorcycle to keep dust and dirt from collecting on it. Avoid using plastic or similar non-breathable, coated materials that restrict air flow and allow heat and moisture to accumulate.

Preparation after Storage

To prepare the motorcycle to be ridden after storage, do the following:

- ▼ Install the battery (if removed) (see page 130).
- ▼ If the motorcycle has been stored for more than four months, change the engine oil (see page 90).
- ▼ Check all the points listed in the Daily Safety Checks section.
- ▼ Before starting the engine, remove the spark plug from the cylinder.
- ▼ Crank the engine on the starter motor several times until the oil pressure light goes out.
- ▼ Replace the spark plug, tightening to 13 lbf ft (17 Nm), and start the engine.
- ▼ Check and if necessary correct the tire pressures (see page 122).
- ▼ Check and if necessary adjust the drive chain tension (see page 102).
- ▼ Clean the entire vehicle thoroughly.
- ▼ Check the brakes for correct operation.
- ▼ Test ride the motorcycle at low speeds.

Table of Contents

Triumph Warranty Terms and Conditions - America and Canada only.....	148
Conditions and Exclusions - America and Canada only.....	149
Noise Control System Warranty.....	150
Tampering With The Noise Control System Prohibited.....	151
Emission Control System Warranty.....	152
California Emissions Control Warranty Statement.....	153
Manufacturers Warranty Coverage.....	154
Owners Warranty Responsibility.....	154
What is Covered by this Emission Warranty.....	156
What Is Not Covered By This Emission Warranty.....	157
Triumph Overseas.....	157
Caring for your Motorcycle.....	158

WARRANTY

Triumph Warranty Terms and Conditions - America and Canada only

Thank you for choosing a Triumph motorcycle. This motorcycle is the product of Triumph's use of proven engineering, exhaustive testing, and continuous striving for superior reliability, safety, and performance.

This section of the Owner's Handbook includes details of the warranty and other useful information concerning your motorcycle.

Make sure that all your owner information is entered in the Triumph Motorcycle Service Handbook that is provided with the motorcycle.

Maintain maximum protection under warranty by making sure that your motorcycle is serviced in accordance with the recommendations of the scheduled maintenance chart in this Owner's Handbook.

If you should sell your motorcycle, make sure this Owner's Handbook or Quick Start Guide (where supplied with the motorcycle) together with all other relevant documents are passed to the new owner. Please advise the new owner that they can notify Triumph of the change of ownership by contacting their local Triumph dealer.

All new Triumph motorcycles are covered by a comprehensive unlimited mileage warranty, commencing from the date of first registration or the date of sale if the motorcycle remains unregistered. Refer to your motorcycle warranty registration certificate for details of the warranty period.

Within the warranty period, TRIUMPH MOTORCYCLES AMERICA LIMITED warrant the new Triumph motorcycle detailed in the Motorcycle Service Handbook to be free from any defect in materials used in the manufacture, and/or workmanship at the time of its manufacture.

Any part found to be defective during this period will be repaired or replaced at the discretion of TRIUMPH MOTORCYCLES AMERICA LIMITED by an authorized Triumph dealer.

Any part replaced under the warranty will be covered for the remaining period of the warranty.

Any parts replaced under warranty must be returned to TRIUMPH MOTORCYCLES AMERICA LIMITED by the dealer/distributor and will become the property of Triumph Motorcycles America Ltd.

Triumph may, at its discretion make any repairs or replacement of defective parts falling outside the warranty, but such work shall not be deemed to be any admission of liability.

Triumph will bear labor charges for work carried out under the warranty.

The warranty may be transferred to subsequent owners for the balance of the remaining warranty period.

Conditions and Exclusions - America and Canada only

- ▼ The motorcycle must not have been used for competition, misused, inadequately or incorrectly serviced or maintained.
- ▼ The motorcycle must have been serviced as detailed in the manufacturers service maintenance schedule, at the intervals specified in the Owner's Handbook and the service log completed accordingly.
- ▼ The motorcycle battery is warranted for 12 (twelve) months from the original date of purchase of the motorcycle. After this 12 (twelve) month period, the battery is excluded from the terms of this warranty. The battery supplied with the motorcycle must be provided with sufficient charge to replenish that lost by the operation of the starting mechanism and/or the use of electrical equipment while the engine is not running.

Refer to the battery section of this handbook for details of required battery maintenance.

The warranty does not cover:

- ▼ Defects caused by incorrect adjustment, repair or modification not authorized by TRIUMPH MOTORCYCLES AMERICA LIMITED.
- ▼ Defects caused by the use of parts and accessories not authorized by TRIUMPH MOTORCYCLES AMERICA LIMITED.
- ▼ The cost of removal and replacement of parts and accessories, unless supplied as original equipment, or recommended by TRIUMPH MOTORCYCLES AMERICA LIMITED.
- ▼ The cost of transportation of the motorcycle to or from the authorized Triumph dealer, or expenses incurred while the motorcycle is unable to be ridden due to warranty repairs.
- ▼ Normal servicing and normal service items, such as spark plugs, oil and air filters are not covered by this warranty. Similarly, items which are expected to wear as part of their normal function such as tires, bulbs, chains, brake pads and clutch plates are also excluded, unless there is a manufacturing defect.
- ▼ Defects to the front fork oil seals as they are subject to wear and tear, including but not limited to damage caused by stone chips to the inner fork tubes.
- ▼ Seats, luggage, paint, chrome, polished aluminum items, or trim deterioration or fading caused by normal wear and tear, exposure, or lack of correct maintenance.
- ▼ Motorcycles used on a commercial basis.
- ▼ Defects which have not been reported to an authorized dealer within ten days of discovery of the defect.
- ▼ Motorcycles which have been inadequately lubricated, or for which the wrong fuel or lubricant has been used.
- ▼ Damages due to water submersion and/or foreign material ingestion.

Should a warranty claim become necessary, Triumph Motorcycles and its authorized dealers shall not be liable for loss of use, inconvenience, lost time, commercial losses or other incidental or consequential damages.

WARRANTY

This warranty shall be governed by and construed in accordance with the laws of England and Wales, save that in the event of any material conflict or inconsistency between such application to this warranty of the laws of England and Wales and local statutory rights that would otherwise be applicable to Triumph customers (dealerships or consumers) purchasing Triumph products in another country, those local statutory rights shall take precedence.

The competent courts of England and Wales shall have primary authority to settle any questions, claims or disputes which may arise under or in connection with this warranty, save that to the extent that any such issue arising requires the consideration and interpretation of applicable local statutory rights applicable to a customer purchasing Triumph products in another country, the customer may seek to take proceedings in any competent court of that country.

Any statement, condition, representation, description, or warranty otherwise contained in any catalog, advertisement or other publication shall not be construed as enlarging, varying or overriding anything contained herein.

Triumph Motorcycles reserve the right to make alterations or improvements without notification to any model or motorcycle without obligation to do so to motorcycles already sold.

This warranty does not affect your statutory rights.

Noise Control System Warranty

NOTICE

This product should be checked for repair or replacement if the motorcycle noise has increased significantly through use, otherwise the owner may become subject to penalties under state and local ordinances.

The following warranty applies to the noise control system and is in addition to the general Triumph warranty and the emission control warranty.

Per 40 C.F.R. § 205.173-1, Triumph Motorcycles America Limited, warrants that this exhaust system, at the time of sale, meets all applicable U.S. E.P.A. federal noise standards. This warranty extends to the first person who buys this exhaust system for purposes other than resale, and to all subsequent buyers. Warranty claims should be directed to an authorized Triumph Motorcycles America dealer.

Triumph Motorcycles America Limited warrants to the first, and each subsequent owner, that the vehicle was designed and built so as to conform, at the time of sale, with the regulations of the U.S. Environmental Protection Agency (as tested following F-76 Drive-By test procedure) and, at the time of manufacture, was free from defects in materials and workmanship which would cause the motorcycle not to meet the U.S. Environmental Protection Agency Standards. This noise control system warranty extends for a period of 1 calendar year or 3,730 miles (6,000 km) whichever occurs first from the date

on which the motorcycle was delivered to the first retail purchaser or, in the case of a demonstration motorcycle or company motorcycle, the date on which the company placed the motorcycle in service prior to retail sale.

Tampering With The Noise Control System Prohibited

Owners are warned that the law prohibits:

- (a) The removal or rendering inoperative by any person other than for purposes of maintenance, repair or replacement, of any device or element of design incorporated into any new vehicle for the purpose of noise control prior to its sale or delivery to the ultimate purchaser or while it is in use and
- (b) the use of the vehicle after such device or element of design has been removed or rendered inoperative by any person.

Acts which are likely to constitute tampering include the following:

- ▼ Removal or tampering with the mufflers, baffles or header pipes or any other component which conducts exhaust gases.
- ▼ Removal of or puncturing of any part of the air intake system.
- ▼ Failure to carry out maintenance as prescribed in the owner's manual.
- ▼ Replacement of any parts of the exhaust or air intake system with parts other than those specified by Triumph Motorcycles America Limited.

WARRANTY

The following items are not covered by the noise control system warranty:

- ▼ Failures which arise through misuse, alterations or accident damage.
- ▼ Replacing, removing, or modifications of any part of the noise control system (consisting of the exhaust system and air intake system) with parts not certified to be noise legal for street use.
- ▼ Triumph Motorcycles America Limited and its authorized dealers shall not be liable for loss of use, inconvenience, lost time, commercial losses or other incidental or consequential damages.
- ▼ Any motorcycle which has had the odometer recorded mileage changed so that the correct mileage of the motorcycle cannot be accurately determined.

Emission Control System Warranty

The following warranty applies to the emission control system and is in addition to the general Triumph warranty and the noise control system warranty.

Triumph Motorcycles America Limited warrants to the first, and each subsequent owner, that the vehicle was designed and built so as to conform, at the time of sale, with the regulations of the U.S. Environmental Protection Agency and the California Air Resources Board and, at the time of manufacture, was free from defects in materials and workmanship which would cause the motorcycle not to meet the U.S. Environmental Protection Agency or California Air Resources Board Standards. This emission control system warranty extends for a period of 5 calendar years or 18,641 miles whichever occurs first, from the date on which the motorcycle was delivered to the first retail purchaser or, in the case of a demonstration motorcycle or company motorcycle, the date on which the company placed the motorcycle in service prior to retail sale.

The following are not covered by the emission control system warranty:

- ▼ Failures which arise through misuse, alterations, accident damage or failure to carry out maintenance as described in the owner's manual.
- ▼ The replacement of any parts required in the maintenance of the emission control system.
- ▼ Triumph Motorcycles America Limited and its authorized dealers shall not be liable for loss of use, inconvenience, lost time, commercial losses or other incidental or consequential damages.
- ▼ Any motorcycle which has had the odometer recorded mileage changed so that the correct mileage of the motorcycle cannot be accurately determined.

California Emissions Control Warranty Statement

Your warranty rights and obligations

The California Air Resources Board and Triumph Motorcycles America Limited are pleased to explain the emission control system on your motorcycle. In California, new motor vehicles must be designed, built and equipped to meet the State's stringent anti-smog standards. Triumph Motorcycles America Limited must warrant the emission control system on your motorcycle for the periods of time listed below provided there has been no abuse, neglect or improper maintenance of your vehicle.

Your emission control system may include parts such as the fuel injection and the ignition system. Also included may be hoses, connectors and other emission related assemblies.

Where a warrantable condition exists, Triumph Motorcycles America Limited will repair your motorcycle at no cost to you including diagnosis, parts and labor.

WARRANTY

Manufacturers Warranty Coverage

For a period of use of five years or 18,641 miles, whichever first occurs: If an emission related part on your motorcycle is defective, the parts will be repaired or replaced by Triumph Motorcycles America Limited. This is your emission control system DEFECTS WARRANTY.

Owners Warranty Responsibility

As the motorcycle owner, you are responsible for the performance of the required maintenance listed in your owner's manual.

Triumph Motorcycles America Limited recommends that you retain all receipts covering maintenance on your motorcycle, but Triumph Motorcycles America Limited cannot deny warranty solely for the lack of receipts or for your failure to ensure the performance of all scheduled maintenance.

You are responsible for presenting your motorcycle to a Triumph Motorcycles America Limited dealer as soon as a problem exists. The warranty repairs should be completed in a reasonable amount of time, not to exceed 30 days.

As the motorcycle owner, you should also be aware that Triumph Motorcycles America Limited may deny you warranty coverage if your motorcycle or a part has failed due to abuse, neglect, improper maintenance or unapproved modifications.

If you have any questions regarding your warranty rights and responsibilities, you should contact Triumph Motorcycles America Limited, Warranty Service Department, 100 Hartsfield Centre Parkway, Suite 200, Atlanta, GA 30354, or the California Air Resources Board at 9528 Telstar Avenue, El Monte, California 91731.

Triumph Motorcycles America Limited warrants to the first, and each subsequent owner, that the vehicle was designed and built so as to conform, at the time of sale, with the regulations of the California Air Resources Board and, at the time of manufacture, was free from defects in materials and workmanship which would cause the motorcycle not to meet the California Air Resources Board Standards.

This warranty period starts the date the motorcycle is delivered to the first retail purchaser or, if the motorcycle is placed in service as a demonstrator or company motorcycle prior to sale at retail, the date it is first placed in service.

The emission control system of each new Triumph motorcycle was designed, built and tested using only genuine Triumph Motorcycle parts and with these parts the motorcycle is certified as being in conformity with California emission control regulations.

WE RECOMMEND THAT ONLY GENUINE TRIUMPH MOTORCYCLE PARTS BE USED FOR MAINTENANCE REPAIR OR REPLACEMENT OF THE EMISSION CONTROL SYSTEM. However, if you are willing to pay for it yourself, you can have replacement or repair of your motorcycle's emission control system performed by any qualified repair establishment or individual using non-genuine parts.

Remember: Use of replacement parts which are not equal in quality to genuine Triumph parts may impair the effectiveness of the emission control system or otherwise damage your motorcycle. If other than genuine Triumph parts are used for maintenance, replacement or repair of

components affecting emission control, you should obtain written assurances that such non-Triumph parts are warranted by their manufacturer to be equal in quality to genuine Triumph Motorcycle parts in both performance and durability. The use of non-Triumph replacement parts does not invalidate the warranty, if any, on other components unless the non-Triumph parts cause damage to warranted parts. However, we recommend that you go only to any authorized Triumph Motorcycle dealer for repairs under warranty, that has factory-trained mechanics and genuine parts. However, in the case of an "emergency" (as defined below) where an authorized Triumph dealer is not reasonably available, you could have repairs performed at any available service establishment or by the owner, using any replacement part. A part not being available within 30 days, or a repair not being complete within 30 days constitutes an emergency. Triumph Motorcycles America Limited will reimburse the owner for such repairs, including diagnosis, only if it is established that the repairs are covered under this emission warranty. Triumph Motorcycles America Limited parts reimbursement, however, will not exceed our suggested retail price for all warranted parts replaced and our labor reimbursement will be limited to our recommended time allowances for emission system repairs at the geographically appropriate hourly labor rate.

To obtain reimbursement from Triumph Motorcycles America Limited for such emergency repairs, you must keep all failed parts and original receipts, marked "paid," so you can present them to an authorized Triumph dealer for their inspection. Triumph Motorcycles America Limited recommends that you bring your motorcycle to an authorized dealer for inspection to ensure that the emergency repairs were done properly.

What is Covered by this Emission Warranty

The emission control system warranty covers the following "warranted parts" only:

- ▼ Fuel injection/engine management equipment including oxygen sensors
- ▼ Intake manifold
- ▼ Air cleaner box
- ▼ Spark advance/retard system
- ▼ Spark plugs (first 10,000 miles)
- ▼ Ignition coils
- ▼ Charcoal canister
- ▼ Cap, fuel tank
- ▼ Fuel/vapor separator (fuel tank)
- ▼ Vapor valve
- ▼ Rollover/pressure control valves
- ▼ If used on the above systems: hoses, clamps, fittings, tubing, sealing gaskets and mounting hardware.

What Is Not Covered By This Emission Warranty

The emission control system warranty does not cover:

Malfunctions in any "warranted parts" caused by any of the following; abuse, misuse, modification, alteration, tampering, disconnection, or improper or inadequate maintenance.

Damage resulting from accident, acts of nature or other events beyond the control of Triumph Motorcycles America Limited.

The repair or replacement of "warranted parts" which are scheduled for replacement prior to 18,641 miles (such as spark plugs, which are scheduled for replacement at 10,000 miles) once these parts have been replaced at the first replacement interval as part of required maintenance services.

Repairs and services performed by anyone other than an authorized Triumph dealer (except in case of emergency). The California Air Resources Board defines an "emergency" as an authorized dealer not being reasonably available or the lack of availability of "warranted parts" within a reasonable time period not to exceed 30 days.

Loss of time, inconvenience, loss of use of the motorcycle, or commercial loss.

Repairs on any motorcycle of which odometer mileage has been changed so that mileage cannot be really determined.

Triumph Overseas

If you are traveling abroad and require assistance or advice from a Triumph dealer, contact the subsidiary or importer for the country which you are visiting.

Subsidiary offices are listed below.

For an up to date list of authorized Triumph dealers and importers, visit www.triumphmotorcycles.co.uk.

Subsidiary Offices

Benelux

Triumph Netherlands

Tel: +31 725 41 0311

Email: Benelux@Triumph.co.uk

Brazil

Triumph Motorcycles Brazil Ltda

Tel: +55 11 3010 1010

Email:

sac.triumph@europ-assistance.com.br

China

British Triumph (Shanghai) Trading Co., Ltd.

Tel: +86 21 6140 9180

Email:

aftersales.china@triumphmotorcycles.com

Denmark/Finland/Norway/Sweden

Triumph Motorcycles AB

Tel: +46 8 680 68 00

Fax: +46 8 680 07 85

France

Triumph S.A.

Tel: +33 1 64 62 3838

Fax: +33 1 64 80 5828

WARRANTY

Germany/Austria

Triumph Motorrad Deutschland GmbH

Tel: +49 6003 829090

Fax: +49 6003 8290927

Italy

Triumph Motorcycles srl

Tel: +39 02 93 454525

Fax: +39 02 93 582575

Japan

Triumph Motorcycles Japan K.K.

Tel: +81 3 6453 9810

Fax: +81 3 6453 9811

Spain/Portugal

Triumph Motocicletas España, S.L

Tel: +34 91 637 7475

Fax: +34 91 636 1134

Thailand

Triumph Thailand

Tel: +66(0)20170333

Fax: +66(0)20170330

United Kingdom/Éire

Triumph Motorcycles Ltd

Tel: +44 1455 45 5012

Fax: +44 1455 45 2211

USA/Canada

Triumph Motorcycles (America) Ltd

Tel: +1 678 854 2010

Fax: +1 678 854 8740

Caring for your Motorcycle

Triumph Motorcycles have taken great care in the selection of materials, plating and painting techniques so as to provide its customers with a quality cosmetic appearance allied to durability. However, motorcycles are often used in hostile environmental conditions and in these circumstances it is essential that the motorcycle is washed, dried and lost lubricity replaced to prevent discoloration particularly of plated and unplated metallic surfaces. Your dealer can provide further information and advice if required. Ultimately the appearance of your motorcycle will very much depend on the care it receives.

For further information in regards to caring for your motorcycle, refer to the Cleaning and Storage section of this Owner's Handbook.

Table of Contents

Speed 400 and Scrambler 400 X.....	160
------------------------------------	-----

SPECIFICATIONS

Speed 400 and Scrambler 400 X

Dimensions, Weights and Performance

A list of model specific dimensions, weights and performance figures is available from your authorized Triumph dealer, or on the Internet at www.triumph.co.uk.

Payload	Speed 400	Scrambler 400 X
Maximum payload (rider, passenger, luggage and accessories)	388 lb (176 kg)	388 lb (176 kg)

Engine	Speed 400	Scrambler 400 X
Engine configuration	Single cylinder four valve DOHC	Single cylinder four valve DOHC
Arrangement	Transverse, single cylinder	Transverse, single cylinder
Displacement	24.3 cu in (398 cc)	24.3 cu in (398 cc)
Bore x stroke	3.5 x 2.52 in (89 x 64 mm)	3.5 x 2.52 in (89 x 64 mm)
Compression ratio	12.0:1	12.0:1
Starting system	Electric starter	Electric starter

Lubrication	Speed 400	Scrambler 400 X
Lubrication system	For crank chamber: Dry sump For rest of the engine: Wet sump and forced lubrication with pump driven oil delivery (Oil enters in crank chamber and it is continuously evacuated by using additional pump)	For crank chamber: Dry sump For rest of the engine: Wet sump and forced lubrication with pump driven oil delivery (Oil enters in crank chamber and it is continuously evacuated by using additional pump)
Engine Oil Capacities:		
Oil capacity (dry fill)	0.59 gallon (2.25 liters)	0.59 gallon (2.25 liters)
Oil capacity (wet fill including oil filter)	0.53 gallon (2 liters)	0.53 gallon (2 liters)
Oil capacity (wet fill excluding oil filter)	0.48 gallon (1.8 liters)	0.48 gallon (1.8 liters)

Cooling System	Speed 400	Scrambler 400 X
Coolant type	Orange - Triumph D2053 OAT coolant (premixed) Green - HP THANDA RAJA B OAT coolant	Orange - Triumph D2053 OAT coolant (premixed) Green - HP THANDA RAJA B OAT coolant
Coolant ratio	50/50	50/50
Cooling system capacity	0.32 gallon (1.2 liters)	0.32 gallon (1.2 liters)
Thermostat opening temperature	88	88

Fuel System	Speed 400	Scrambler 400 X
Fuel injection system	Electronic	Electronic
Injector type	Single point injection into induction manifold	Single point injection into induction manifold
Fuel pump type	Submerged	Submerged
Fuel pressure (nominal)	50.8 lb/in ² (3.5 bar / 350 kPa)	50.8 lb/in ² (3.5 bar / 350 kPa)

SPECIFICATIONS

Fuel	Speed 400	Scrambler 400 X
Fuel type	Unleaded, 91 RON (U.S. 87 CLC/AKI)	Unleaded, 91 RON (U.S. 87 CLC/AKI)
Fuel tank capacity	3.4 gallons (13 liters)	3.4 gallons (13 liters)

Ignition	Speed 400	Scrambler 400 X
Ignition system	Digital Inductive	Digital Inductive
Electronic rev limiter	9,500 rpm	9,500 rpm
Spark plug type	Bosch VR6NEU	Bosch VR6NEU
Spark plug gap	0.035 in +0.00/-0.004 in (0.9 mm +0.00/-0.1 mm)	0.035 in +0.00/-0.004 in (0.9 mm +0.00/-0.1 mm)

Transmission	Speed 400	Scrambler 400 X
Transmission type	6 Speed, Constant Mesh	6 Speed, Constant Mesh
Clutch type	Multi plate wet clutch operated via LHS hand lever	Multi plate wet clutch operated via LHS hand lever
Final drive chain	520 Series X-ring chain	520 Series X-ring chain
Number of links	104	106
Chain length (20 links)	12.74 in (323.7 mm)	12.74 in (323.7 mm)
Primary drive ratio	2.839:1 (88/31)	2.839:1 (88/31)
Final drive ratio	3.36:1 (43/15)	3.07:1 (43/14)
Gear ratios - 1st gear	2.83:1 (34/12)	2.83:1 (34/12)
Gear ratios - 2nd gear	1.93:1 (29/15)	1.93:1 (29/15)
Gear ratios - 3rd gear	1.42:1 (27/19)	1.42:1 (27/19)
Gear ratios - 4th gear	1.14:1 (24/21)	1.14:1 (24/21)
Gear ratios - 5th gear	0.96:1 (22/23)	0.96:1 (22/23)
Gear ratios - 6th gear	0.84:1 (21/25)	0.84:1 (21/25)

WARNING

Use the recommended tires **ONLY** in the combinations listed in the approved Tire Selector at www.triumph.co.uk.

Do not mix tires from different manufacturers or mix different specification tires from the same manufacturers.

Using/mixing tires may affect the handling, stability, braking and traction control (if equipped) functions of the motorcycle.

Failure to follow the advice above may lead to loss of motorcycle control which could result in serious injury or death.

Approved Tires

A list of approved tires specific to these models is available from your authorized Triumph dealer, or on the Internet at www.triumph.co.uk.

Tires	Speed 400	Scrambler 400 X
Tire Sizes:		
Front tire size	110/70 R17 54H	100/90-19 57V
Rear tire size	150/60 R17 66H	140/80 R17 69V
Tire Pressures (Cold):		
Front tire pressure	26.0 lb/in ² (1.79 bar / 179 kPa)	26.0 lb/in ² (1.79 bar / 179 kPa)
Rear tire pressure	33.0 lb/in ² (2.28 bar / 228 kPa)	33.0 lb/in ² (2.28 bar / 228 kPa)

Electrical Equipment	Speed 400	Scrambler 400 X
Battery type	ETZ-9 or YTX9-BS	ETZ-9 or YTX9-BS
Battery rating	12 Volt, 8 Ah	12 Volt, 8 Ah
Alternator rating	14 Volt, 18.5 Amp at 4,000 rpm	14 Volt, 18.5 Amp at 4,000 rpm
Front position light	LED	LED
Headlight	LED	LED
Rear/brake light	LED	LED
License plate light	LED	LED
Turn signal lights	LED	LED

SPECIFICATIONS

Torque Figures	Speed 400	Scrambler 400 X
Rider seat fasteners	Not Applicable	40 lbf in (4.5 Nm)
Front left cover finisher fasteners	62 lbf in (7 Nm)	62 lbf in (7 Nm)
Front left engine cover fasteners	8 lbf ft (11 Nm)	8 lbf ft (11 Nm)
Engine oil drain plug	10 lbf ft (13 Nm)	10 lbf ft (13 Nm)
Evacuation strainer plug	89 lbf in (10 Nm)	89 lbf in (10 Nm)
Oil filter cover fasteners	8 lbf ft (11 Nm)	8 lbf ft (11 Nm)
Clutch cable lower lock nut	11 lbf ft (15 Nm)	11 lbf ft (15 Nm)
Rear wheel spindle nut	72 lbf ft (98 Nm)	72 lbf ft (98 Nm)
Drive chain adjuster lock nut	8 lbf ft (11 Nm)	8 lbf ft (11 Nm)
Drive chain guard fasteners	80 lbf in (9 Nm)	80 lbf in (9 Nm)
Battery terminal fasteners	40 lbf in (4.5 Nm)	40 lbf in (4.5 Nm)
Spark plug	13 lbf ft (17 Nm)	13 lbf ft (17 Nm)

Fluids and Lubricants	All Models
Bearings and pivots	Triumph Performance RG2 grease (NLGI 2)
Brake fluid	Triumph Performance DOT 4 brake fluid
Coolant	Orange - Triumph D2053 OAT coolant (premixed) Green - HP THANDA RAJA B OAT coolant
Drive chain	Triumph Performance chain lubricant
Engine oil	Fully synthetic 10W/50 motorcycle engine oil which meets specification API SN (or higher) and JASO MA2. Semi synthetic engine oil must not be used. Triumph Performance fully synthetic engine oil is recommended

- A**
- Anti-Lock Braking System (ABS)..... 72
 - Indicator Light..... 29
- B**
- Bank Angle Indicators..... 120
 - Battery
 - Charging..... 129
 - Discharge..... 128
 - Disposal..... 127
 - Installation..... 130
 - Maintenance..... 128
 - Removal..... 127
 - Storage..... 128
 - Brakes..... 108
 - Anti-Lock Braking System (ABS)..... 72
 - Breaking-in New Brake Discs and Pads..... 108
 - Disc Brake Fluid..... 109
 - Front Brake Fluid Adjustment..... 110
 - Front Brake Fluid Inspection..... 110
 - Front Brake Wear Inspection..... 107
 - Light Switches..... 112
 - Pad Wear Compensation..... 108
 - Rear Brake Fluid Level Adjustment..... 112
 - Rear Brake Fluid Level Inspection..... 112
 - Rear Brake Fluid Reservoir..... 112
 - Rear Brake Wear Inspection..... 108
 - Breaking-In..... 63
- C**
- Cleaning
 - After Washing..... 140
 - Aluminum Items - not Lacquered or Painted..... 141
 - Black Chrome Items..... 142
 - Chrome and Stainless Steel..... 141
 - Exhaust System..... 142
 - Frequency of Cleaning..... 138
 - Gloss Paintwork..... 140
 - Matt Paintwork..... 140
 - Monsoon..... 144
 - Preparation for Washing..... 138
 - Seat Care..... 143
 - Washing..... 139
 - Where to be Careful..... 139
 - Windshield..... 144
 - Cleaning and Storage..... 138
 - Clock..... 33, 38
 - Clutch..... 99
 - Cable Adjustment..... 99
 - Inspection..... 99
 - Cooling System..... 95
 - Coolant Change..... 97
 - Coolant Level Adjustment..... 97
 - Coolant Level Inspection..... 96
 - Corrosion Inhibitors..... 95
 - High Coolant Temperature Warning Light..... 28
- D**
- Daily Safety Checks..... 64
 - Daytime Running Lights (DRL)..... 30, 46
 - Drive Chain..... 101
 - Damage Inspection..... 104
 - Free Movement Adjustment..... 102
 - Free Movement Inspection..... 102
 - Lubrication..... 101
 - Sprockets Wear Inspection..... 105
 - Wear Inspection..... 104, 105
- E**
- Engine
 - Moving Off..... 68
 - Starting the Engine..... 67
 - Stopping the Engine..... 66

INDEX

- | | |
|--|--------|
| Engine Oil..... | 89 |
| Level Inspection..... | 90 |
| Oil and Oil Filter Change..... | 91 |
| Specification and Grade..... | 94 |
| Engine Run/Stop Switch | |
| RUN Position..... | 45 |
| STOP Position..... | 45 |
| F | |
| Front Fork Inspection..... | 118 |
| Fuel..... | 48 |
| Average Fuel Consumption..... | 36 |
| Current Fuel Consumption..... | 36 |
| Filling the Fuel Tank..... | 50 |
| Fuel Gage..... | 32 |
| Fuel Grade..... | 48 |
| Fuel Tank Cap..... | 50 |
| Low Fuel Indicator Light..... | 31 |
| Range To Empty..... | 36 |
| Refueling..... | 49 |
| Fuses..... | 131 |
| Identification..... | 132 |
| Location..... | 131 |
| G | |
| Gears | |
| Gear Position..... | 33 |
| Shifting..... | 68 |
| H | |
| Handbook and Tool Kit | |
| Handbook..... | 61 |
| Tool Kit..... | 61 |
| Hazard Warning Lights..... | 45 |
| Headlight(s)..... | 133 |
| Adjustment..... | 134 |
| Daytime Running Lights (DRL)..... | 135 |
| Replacement..... | 135 |
| Heated Grips..... | 34 |
| High Beam Switch..... | 46 |
| High Speed Operation..... | 74 |
| Horn Button..... | 46 |
| I | |
| Ignition | |
| Ignition Switch/Steering Lock..... | 43 |
| Immobilizer..... | 44 |
| Instruments | |
| Average Fuel Consumption..... | 36 |
| Clock..... | 33, 38 |
| Current Fuel Consumption..... | 36 |
| Fuel Gage..... | 32 |
| Gear Position..... | 33 |
| Heated Grips..... | 34 |
| Instruments Display Layout..... | 26 |
| Odometer..... | 32 |
| Off-Road Mode..... | 37 |
| Range to Empty..... | 36 |
| Service..... | 34 |
| Side Stand..... | 33 |
| Speedometer..... | 31 |
| Tachometer..... | 32 |
| Trip Meter..... | 35 |
| Triumph Traction Control..... | 37 |
| Units..... | 38 |
| Warning Lights..... | 27 |
| L | |
| Left Handlebar Switches..... | 46 |
| Daytime Running Lights (DRL) Switch..... | 46 |
| Heated Grips Button..... | 47 |
| High Beam Switch..... | 46 |
| Horn Button..... | 46 |
| SCROLL/SELECT Button..... | 46 |
| Turn Signal Switch..... | 46 |
| License Plate Light..... | 135 |
| Lights..... | 133 |
| Hazard Warning Lights..... | 30 |
| Headlight Adjustment..... | 134 |
| Headlight Replacement..... | 135 |
| License Plate Light..... | 135 |
| Position Light..... | 135 |
| Tail Light..... | 135 |
| Turn signals..... | 135 |

- M**
- Maintenance
 - Scheduled Maintenance..... 85
 - Mirrors..... 113
 - Bar End Mirrors..... 113
 - Mirror Adjustment..... 114
 - Multi-function Display..... 32
- O**
- Odometer..... 32
 - Off-Road
 - Off-Road Mode..... 37
 - Off-Road Use..... 05
- P**
- Parking..... 73
 - Parts Identification..... 18, 19, 20, 21
 - Rider View..... 22
 - Position Light..... 135
- R**
- Rider View..... 22
 - Right Handlebar Switches..... 45
 - Engine Run/Stop Switch..... 45
 - Hazard Warning Light Switch..... 45
 - RUN Position..... 45
 - START Button..... 45
 - STOP Position..... 45
- S**
- Safety
 - Fuel and Exhaust Fumes..... 08, 66, 89
 - Handlebars and Footrests..... 13
 - Helmet and Clothing..... 08
 - Maintenance and Equipment..... 09
 - Parking..... 10
 - Parts and Accessories..... 14, 78
 - Riding..... 11
 - The Motorcycle..... 07, 80
 - Scheduled Maintenance
 - Disposal of Used Fluids..... 86
 - Scheduled Maintenance Table..... 87
 - SCROLL/SELECT Button..... 46
 - Seats..... 56
 - Passenger Seat Installation..... 60
 - Passenger Seat Removal..... 58
 - Rider's Seat Installation..... 59
 - Rider's Seat Removal..... 58
 - Seat Care..... 56, 143
 - Seat Installation..... 59
 - Seat Lock..... 57
 - Seat Removal..... 57
 - Serial Numbers
 - Engine Serial Number..... 23
 - Vehicle Identification Number..... 23
 - Service..... 34
 - Side Panels..... 54
 - Installation..... 55, 56
 - Removal..... 54, 54
 - Side Stand..... 33, 53
 - Specifications
 - Cooling System..... 161
 - Electrical Equipment..... 163
 - Engine..... 160
 - Fluids and Lubricants..... 164
 - Fuel..... 162
 - Fuel System..... 161
 - Ignition..... 162
 - Lubrication..... 161
 - Payload..... 160
 - Tires..... 163
 - Torque Figures..... 164
 - Transmission..... 162
 - Speedometer..... 31
 - Stand
 - Side Stand..... 53
 - START Button..... 45
 - Steering Bearings
 - Inspection..... 116
 - Steering/Wheel Bearings..... 115
 - Storage
 - Preparation after Storage..... 146
 - Preparation for Storage..... 145

Suspension

Front Fork Inspection	118
Front Suspension	118
Rear Spring Preload Adjustment	119
Rear Suspension	119
Rear Suspension Settings	119

T

Tachometer	32
Tail Light	135
Throttle Control	42, 98
Inspection	99
Tires	121
Minimum Tread Depth	123
Replacement	123
Tire Inflation Pressures	122
Tire Type	121
Tire Wear	122
Traction Control (TC)	51
Disable	52
Settings	51
Triumph Traction Control (TTC) Setting	37
Trip Meter	35
Turn signals	46, 135

U

Units	38
Universal Serial Bus (USB) Socket	62

W

Warning Lights

Daytime Running Lights (DRL) (if equipped)	30
Engine Immobilizer Indicator Light	28
Engine Management System Malfunction Indicator Light (MIL)	27
High Beam Indicator Light	30
Low Oil Pressure Warning Light	27
Neutral Indicator Light	31
Traction Control (TC) Disabled Warning Light	30
Traction Control (TC) Indicator Light	29
Turn signal Light	30
Warnings	04
Immobilizer and TPMS	170
Maintenance	04
Noise Control System	05
Owner's Handbook	03
Warning Label Locations	16, 17
Warning Labels	04
Wheel Bearings	
Inspection	117
Windshield	
Cleaning	144

This section contains approval information that is required to be included in this Owner's Handbook.

Radio Equipment Device EU Directive 2014/53

Triumph motorcycles are equipped with a range of radio equipment devices. These radio equipment devices must comply with the EU Radio Equipment Device Directive 2014/53/EU. The complete text of the EU declaration of conformity for each radio equipment device is available at the following address:

www.triumphmotorcycles.co.uk/public-content/triumph-radio-device-approvals

The table below shows the frequencies and power levels for the radio equipment devices in compliance with the EU Directive 2014/53/EU. The table shows all radio equipment devices used across the Triumph range of motorcycles. Only certain radio equipment devices in the table are applicable to specific motorcycles.

Radio Equipment Device	Frequency Range	Maximum Transmit Power Level	Manufacturer
Immobilizer	Receive Bands: 119 kHz to 135 kHz Transmit Bands: 119 kHz to 135 kHz	-4.7dB A/m@ 10m	Minda Corporation Ltd Noida, Uttar Pradesh, India

FCC Statement

This device complies with part 15 of the Federal Communications Commission (FCC) Rules.

Operation is subject to the following two conditions:

- ▼ This device may not cause harmful interference.
- ▼ This device must accept any interference received, including interference that may cause undesired operation.

Changes or modifications to the device could void the user's authority to operate the equipment.

Canadian Approval

This device contains license-exempt transmitter(s)/receiver(s) that comply with Innovation, Science and Economic Development Canada's license-exempt RSS(s).

Operation is subject to the following two conditions:

1. This device may not cause interference.
2. This device must accept any interference, including interference that may cause undesired operation of the device.

Radio frequency radiation exposure information:

This equipment complies with radiation exposure limits set forth for an uncontrolled environment. This equipment should be installed and operated with minimum distance of 20 cm between the radiator and your body.