

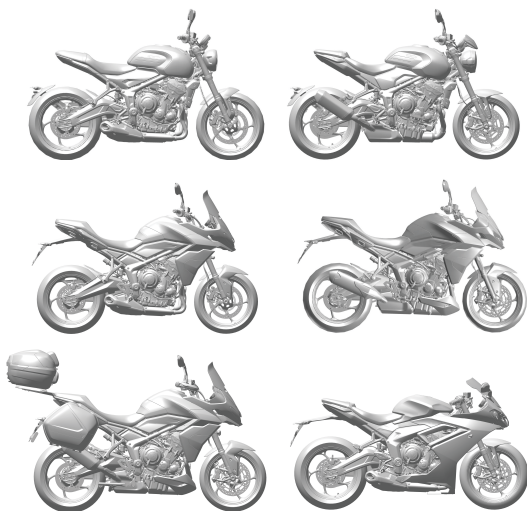

**Trident 660, Trident 660 - Triple Tribute,
Trident 800, Tiger Sport 660, Tiger Sport 800,
Tiger Sport 800 Tour and Daytona 660**



This handbook contains information on the Triumph Trident 660, Trident 660 - Triple Tribute, Trident 800, Tiger Sport 660, Tiger Sport 800, Tiger Sport 800 Tour and Daytona 660 motorcycles. Always store this Owner's Handbook with the motorcycle and refer to it for information whenever necessary.

The information contained in this publication is based on the latest information available at the time of printing. Triumph reserves the right to make changes at any time without prior notice, or obligation.

Not to be reproduced wholly or in part without the written permission of Triumph Motorcycles America Limited. Este Manual del propietario está disponible en español.

© Copyright 08.2025 Triumph Motorcycles America Limited.

Publication part number 3850253-US-EN issue 1

This handbook contains a number of different sections. The table of contents below will help you find the beginning of each section where, in the case of the major sections, a further table of contents will help you find the specific subject required.

- 03** FOREWORD
- 09** SAFETY FIRST
- 18** WARNING LABELS
- 30** PARTS IDENTIFICATION
- 49** SERIAL NUMBERS
- 51** INSTRUMENTS
- 93** GENERAL INFORMATION
- 145** HOW TO RIDE THE MOTORCYCLE
- 159** ACCESSORIES, LOADING AND PASSENGERS
- 165** MAINTENANCE AND ADJUSTMENT
- 241** CLEANING AND STORAGE
- 253** WARRANTY
- 267** SPECIFICATIONS
- 299** INDEX
- 304** APPROVAL INFORMATION

Owner's Handbook

WARNING

The Owner's Handbook or Quick Start Guide (where supplied with the motorcycle), and all other documents that are supplied with your motorcycle, should be considered a permanent part of your motorcycle and should remain with it, even if your motorcycle is subsequently sold.

All riders must read the Owner's Handbook, Quick Start Guide, and all other documents supplied with your motorcycle before riding, in order to become thoroughly familiar with the correct operation of your motorcycle's controls, its features, capabilities and limitations.

Do not lend your motorcycle to others as riding when not familiar with your motorcycle's controls, features, capabilities and limitations may lead to loss of motorcycle control, which could result in serious injury or death.

Thank you for choosing a Triumph motorcycle. This motorcycle is the product of Triumph's use of proven engineering, exhaustive testing, and continuous striving for superior reliability, safety and performance.

Please read this Owner's Handbook before riding in order to become thoroughly familiar with the correct operation of your motorcycle's controls, its features, capabilities and limitations.

This Owner's Handbook includes safe riding tips, but does not contain all the techniques and skills necessary to ride a motorcycle safely.

Triumph strongly recommends that all riders undertake the necessary training to ensure safe operation of this motorcycle.

The latest version of this Owner's Handbook containing any changes is available from your local dealer and online from www.triumphtechnicalinformation.com/handbooks in:

- ▼ English
- ▼ US English
- ▼ Arabic
- ▼ Chinese
- ▼ Dutch
- ▼ French
- ▼ German
- ▼ Italian
- ▼ Japanese
- ▼ Portuguese (Brazil)
- ▼ Spanish
- ▼ Swedish
- ▼ Thai
- ▼ Finnish, Polish, Portuguese and Slovak (available online only from www.triumphtechnicalinformation.com/handbooks).

The languages available for this Owner's Handbook are dependent on the specific motorcycle model and country.

FOREWORD

QR Code

To download the Owner's Handbook;

Enter the address below into a web browser:

www.triumphtechnicalinformation.com/handbooks

Or;

Scan the QR code using your smart device:



This QR code can also be found on a label permanently attached to your motorcycle, located either under the seat or behind the side panel.

After entering the web address or scanning the QR code, your browser will be directed to a web page where you can select and download your Owner's Handbook.

We recommend that you download and store a copy of the Owner's Handbook for use offline. As information contained within the handbook may change, we recommend downloading and replacing your handbook on a regular basis to make sure it is kept up to date.

Triumph Technical Information (TTI)

For maintenance procedures that require specialist knowledge or service tools, these are referred to the Service Manual which can be accessed at www.triumphtechnicalinformation.com.

Or;

Scan the QR code using your smart device:



Registration is required to access the site.

Dangers, Warnings, Cautions and Notices

Particularly important information is presented in the following form:

DANGER

This danger symbol identifies special instructions or procedures, which, if not correctly followed, will result in serious injury, or death.

WARNING

This warning symbol identifies special instructions or procedures, which, if not correctly followed, could result in serious injury, or death.

CAUTION

This caution symbol identifies special instructions or procedures, which, if not strictly observed, could result in minor or moderate injury.

NOTICE

This notice symbol indicates points of particular interest for more efficient and convenient operation.

Warning Labels



At certain areas of the motorcycle, the symbol above can be seen. The symbol means CAUTION: REFER TO THE HANDBOOK and will be followed by a pictorial representation of the subject concerned and/or text.

Never attempt to ride the motorcycle or make any adjustments without reference to the relevant instructions contained in this handbook.

For the location of all labels showing this symbol, see the Warning Label Locations section of this Owner's Handbook. Where necessary, this symbol will also appear on the pages containing the relevant information.

Maintenance

To ensure a long, safe, and trouble-free life for your motorcycle, maintenance should only be carried out by a competent person with the specialist knowledge and technical understanding of motorcycles, such as an authorized Triumph dealer.

An authorized Triumph dealer will have the necessary knowledge, equipment, and skills to maintain your Triumph motorcycle correctly.

To locate your nearest authorized Triumph dealer, visit the Triumph web site at www.triumphmotorcycles.co.uk/ dealers or telephone the authorized distributor in your country. Their address is given in the service record book that accompanies this handbook.

Noise Control System

Tampering with the noise control system is prohibited.

Owners are warned that the law may prohibit:

- ▼ The removal or rendering inoperative by any person other than for purposes of maintenance, repair or replacement, of any device or element of design incorporated into any new vehicle for the purpose of noise control prior to its sale or delivery to the ultimate purchaser or while it is in use and,
- ▼ The use of the vehicle after such device or element of design has been removed or rendered inoperative by any person.

Among those acts presumed to constitute tampering are the acts listed below:

- ▼ Removal of, or puncturing the muffler, baffles, header pipes or any other component that conducts exhaust gases.
- ▼ Removal of, or puncturing of any part of the intake system.
- ▼ Lack of proper maintenance.
- ▼ Replacing any moving parts of the vehicle, or parts of the exhaust or intake system, with parts other than those specified by the manufacturer.

Relocating the Motorcycle

Rules and regulations vary between countries. Therefore, when moving countries and relocating your Triumph motorcycle, it is your responsibility to make sure that the motorcycle meets local rules and regulations.

Talk to Triumph

Our relationship with you does not end with the purchase of your Triumph. Your feedback on the buying and ownership experience is very important in helping us develop our products and services for you.

Please help us by ensuring your authorized Triumph dealership has your email address and registers this with us. You will then receive an online customer satisfaction survey invitation to your email address where you can give us this feedback.

Your Triumph Team.

This page intentionally left blank

The Motorcycle

WARNING

This motorcycle is designed for on-road use only.

Do not ride this motorcycle off-road.

Off-road operation may lead to loss of motorcycle control which could result in serious injury or death.

WARNING

This motorcycle is designed for use as a two-wheeled vehicle capable of carrying a rider and up to one passenger (subject to a passenger seat and footrests being installed).

The total weight of the rider, and any passenger, accessories and luggage must not exceed the maximum load limit as specified in the Specifications section.

Failure to follow the advice above may lead to loss of motorcycle control, which could result in serious injury or death.

WARNING

This motorcycle is equipped with a catalytic converter, which along with the exhaust system, reaches a very high temperature during engine operation.

Flammable materials such as grass, hay/straw, leaves, clothing and luggage, could ignite if allowed to come into contact with any part of the exhaust system and catalytic converter.

Always make sure flammable materials do not come into contact with the exhaust system or catalytic converter.

Failure to follow the advice above may cause a fire, which could result in serious injury or death.

WARNING

This motorcycle is not designed to tow a trailer or be equipped with a sidecar.

Equipping a sidecar and/or a trailer may affect the handling, stability or other aspects of the motorcycle operation.

Failure to follow the advice above may lead to loss of motorcycle control, which could result in serious injury or death.

NOTICE

Riding the motorcycle in extreme conditions, such as on wet and muddy roads, rough terrain or in dusty and humid environments, may lead to above average wear and damage of certain components.

Therefore the servicing and replacement of worn or damaged components may be necessary before the scheduled maintenance service is reached.

It is important that the motorcycle is inspected after riding in extreme conditions and any worn or damaged components are serviced or replaced.

Fuel and Exhaust Fumes** DANGER**

Never start the engine or run the engine in a confined area.

Always operate the motorcycle in the open air or in an area with adequate ventilation.

Exhaust fumes are poisonous and will cause loss of consciousness and death within a short period of time.

 WARNING

GASOLINE IS HIGHLY FLAMMABLE:

- Always turn off the engine when refueling.
- Pay full attention and remain alert while refueling.
- Do not refuel or open the fuel filler cap while smoking or in the vicinity of any open (naked) flame.
- Take care not to spill any gasoline on the engine, exhaust pipes or mufflers when refueling.
- If gas is swallowed, inhaled or allowed to get into the eyes, seek immediate medical attention.
- Spillage on the skin should be immediately washed off with soap and water and clothing contaminated with gas should immediately be removed.
- Burns and other serious skin conditions may result from contact with gas.

Failure to follow the advice above could result in serious injury or death.

Helmet and Clothing



DANGER

A helmet is one of the most important pieces of riding gear as it offers protection against head injuries. You and your passenger's helmet should be carefully chosen and should fit you or your passenger's head comfortably and securely. A brightly colored helmet will increase a rider's (or passenger's) visibility to other operators of road vehicles.

An open face helmet offers some protection in an accident, though a full face helmet will offer more.

Always wear a visor or approved goggles to help vision and to protect your eyes.

Failure to follow the advice above will result in serious injury or death.

WARNING

When riding the motorcycle, both rider and passenger (on models where carrying a passenger is permitted) must always wear appropriate clothing including a motorcycle helmet, eye protection, gloves, boots, trousers (close fitting around the knee and ankle) and a brightly colored jacket.

During off-road use (on models suitable for off-road use), the rider must always wear appropriate clothing including trousers and boots.

Brightly colored clothing will considerably increase a rider's (or passenger's) visibility to other operators of road vehicles.

Although full protection is not possible, wearing correct protective clothing can reduce the risk of serious injury or death.

When choosing a helmet, always look for a DOT (Department of Transport) sticker indicating that the helmet has DOT approval. Do not buy a helmet without DOT approval.

SAFETY FIRST

Maintenance and Equipment

WARNING

Whenever there is doubt as to the correct or safe operation of this motorcycle, contact a competent person with the specialist knowledge and technical understanding of motorcycles, such as an authorized Triumph dealer.

Operation of an incorrectly performing motorcycle may aggravate a fault and may also compromise safety.

Continued operation of an incorrectly performing motorcycle may affect the handling, stability or other aspects of the motorcycle operation, leading to loss of motorcycle control, which could result in serious injury or death.

WARNING

Make sure all equipment that is required by law is installed and functioning correctly.

The removal or alteration of the motorcycle's lights, mufflers, emission or noise control systems can violate the law.

Incorrect or improper modification may affect the handling, stability or other aspects of the motorcycle's operation, leading to loss of motorcycle control, which could result in serious injury or death.

WARNING

If the motorcycle is involved in an accident, collision or fall, it must be taken for inspection and repair.

Inspections and repairs must be completed by a competent person with the specialist knowledge and technical understanding of motorcycles, such as an authorized Triumph dealer.

Any accident can cause damage to the motorcycle that, if not correctly repaired, may cause a second accident, which could result in serious injury or death.

Parking

WARNING

Always switch off the engine and remove the ignition key before leaving the motorcycle unattended. By removing the key, the risk of use of the motorcycle by unauthorized or untrained persons is reduced.

When parking the motorcycle, always remember the following:

- Engage first gear to help prevent the motorcycle from rolling off the stand.
- The engine, radiator, exhaust system, rear suspension unit and brakes will be hot after riding. DO NOT park where pedestrians, animals and/or children are likely to touch the motorcycle.
- Do not park on soft ground or on a steeply inclined surface. Parking under these conditions may cause the motorcycle to fall over.

For further details, refer to the How to Ride the Motorcycle section of this Owner's Handbook.

Failure to follow the advice above could result in damage to property, serious injury or death.

Riding

DANGER

Never ride the motorcycle when fatigued or under the influence of alcohol or other drugs.

Riding when under the influence of alcohol or other drugs is illegal.

Riding when fatigued or under the influence of alcohol or other drugs reduces the rider's ability to maintain control, leading to loss of motorcycle control, which will result in serious injury or death.

WARNING

All riders must be licensed to operate the motorcycle.

Operation of the motorcycle without a license is illegal and could lead to prosecution.

Operation of the motorcycle without formal training in the correct riding techniques that are necessary to become licensed is dangerous.

Failure to follow the advice above may lead to loss of motorcycle control, which could result in serious injury or death.

SAFETY FIRST

WARNING

Always ride defensively and wear the protective equipment mentioned elsewhere in this Safety First section.

Remember, in an accident, a motorcycle does not give the same impact protection as a car.

Failure to follow the advice above could result in serious injury or death.

WARNING

This motorcycle should be operated within the legal speed limits for the particular road traveled.

Riding a motorcycle at high speeds can be dangerous since the time available to react to a hazard is greatly reduced at high speeds.

Always reduce speed in potentially hazardous driving conditions, such as bad weather or heavy traffic.

Failure to follow the advice above may lead to loss of motorcycle control, which could result in serious injury or death.

WARNING

Continually observe and react to changes in road surface, traffic and wind conditions. All two-wheeled vehicles are subject to external forces, which may affect the handling, stability or other aspects of the motorcycle's operation.

These forces include but are not limited to:

- Wind draft from passing vehicles
- Potholes, uneven or damaged road surfaces
- Bad weather
- Rider error.

Always operate the motorcycle at moderate speed and away from heavy traffic until you have become thoroughly familiar with its handling and operating characteristics. Never exceed the legal speed limit.

Failure to follow the advice above may lead to loss of motorcycle control, which could result in serious injury or death.

Wobble/Weave

A weave is a relatively slow oscillation of the rear of the motorcycle, while a wobble is a rapid, possibly strong shaking of the handlebar. These are related but distinct stability problems, usually caused by excessive weight in the wrong place, or by a mechanical problem such as worn or loose bearings or under-inflated or unevenly worn tires.

Your solution to both situations is the same. Keep a firm hold on the handlebars without locking arms or fighting the steering. Smoothly ease off the throttle to slow gradually. Do not apply the brakes, and do not accelerate to try to stop the wobble or weave. In some cases, it helps to shift your body weight forward by leaning over the tank.

Copyright © 2005 Motorcycle Safety Foundation. All rights reserved. Used with permission.

Handlebars and Footrests

WARNING

The rider must maintain control of the motorcycle by keeping hands on the handlebars at all times.

The handling and stability of a motorcycle will be affected if the rider removes their hands from the handlebars.

Failure to follow the advice above may lead to loss of motorcycle control, which could result in serious injury or death.

WARNING

The rider and passenger (if applicable) must always use the footrests provided, during operation of the motorcycle.

By using the footrests, both rider and passenger will reduce the risk of inadvertent contact with any motorcycle components and will also reduce the risk of injury from entrapment of clothing.

Failure to follow the advice above may lead to loss of motorcycle control, which could result in serious injury or death.

SAFETY FIRST

WARNING

Always make sure that the passenger footrests are fully extended when carrying a passenger.

Never carry a passenger without them using the fully extended passenger footrests.

Incorrect foot placement anywhere on the motorcycle instead of using the footrests may cause:

- The passenger's feet or clothing to become trapped
- The passenger to be in contact with hot exhaust pipes.

Failure to follow the advice above may lead to loss of motorcycle control, which could result in damage to property, serious injury or death.

WARNING

The bank angle indicators must not be used as a guide to how far the motorcycle may be safely banked.

This depends on many various conditions including, but not limited to:

- Road surface
- Tire condition
- Weather.

Banking to an unsafe angle may lead to loss of motorcycle control, which could result in serious injury or death.

WARNING

Always replace the bank angle indicators before they are worn to their maximum limit.

Use of a motorcycle with bank angle indicators worn beyond the maximum limit will allow the motorcycle to be banked to an unsafe angle.

Banking to an unsafe angle may lead to loss of motorcycle control which could result in serious injury or death.

WARNING

When banking and the bank angle indicator, attached to the rider's footrest, makes contact with the ground, the motorcycle is nearing its bank angle limit.

A further increase of the banking angle is unsafe.

Banking to an unsafe angle may lead to loss of motorcycle control which could result in serious injury or death.

Parts and Accessories

WARNING

Owners should be aware that the only approved parts, accessories and conversions for any Triumph motorcycle are those that carry official Triumph approval.

We recommend accessories and conversions be completed by a competent person with the specialist knowledge and technical understanding of motorcycles, such as an authorized Triumph dealer.

In particular, it is extremely hazardous to install or replace parts or accessories whose installation requires the dismantling of, or addition to, either the electrical or fuel systems. Any such modification could cause a safety hazard.

The installation of any non-approved parts, accessories or conversions may affect the handling, stability or other aspects of the motorcycle's operation, leading to loss of motorcycle control, which could result in serious injury or death.

Triumph does not accept any liability whatsoever for defects caused by the installation of non-approved parts, accessories or conversions.

Triumph does not accept any liability whatsoever for defects caused by the incorrect installation of approved parts, accessories or conversions.

WARNING LABELS

Trident 660 and Trident 660 - Triple Tribute

Trident 660 shown

Left Hand Side

NOTICE

The labels detailed on this and the following pages draw your attention to important safety information in this handbook. Before riding, make sure that you have understood and complied with all the information to which these labels relate.

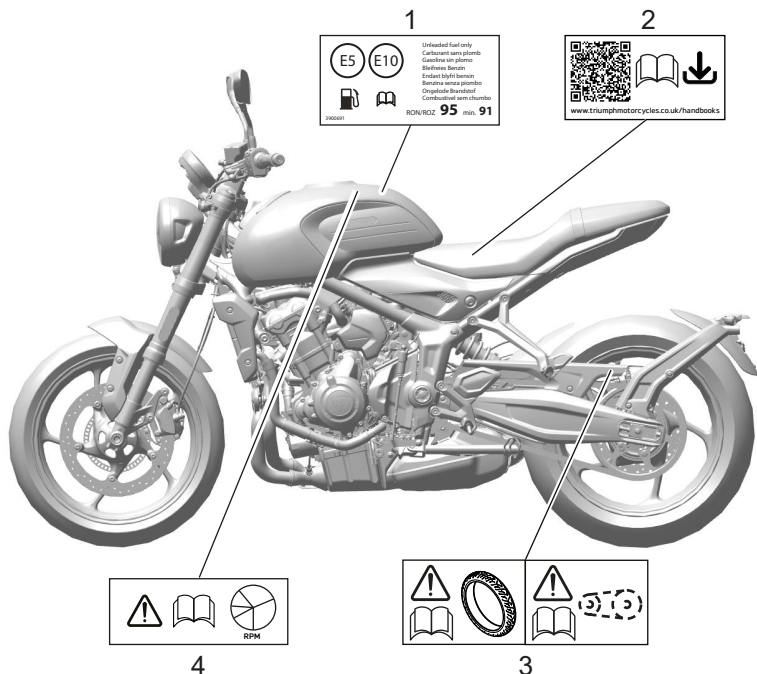

1. E5 and E10 Fuel (if equipped) (page 104)
2. Owner's Handbook Download Details (under seat)

3. Tires (page 216) and Drive Chain (page 188)
4. Breaking-In (page 142)

Right Hand Side

NOTICE

All warning labels and decals, with the exception of the Breaking-in label, are mounted on the motorcycle using a strong adhesive. In some cases, labels are installed prior to an application of paint lacquer. Therefore, any attempt to remove the warning labels will cause damage to the paintwork or bodywork.

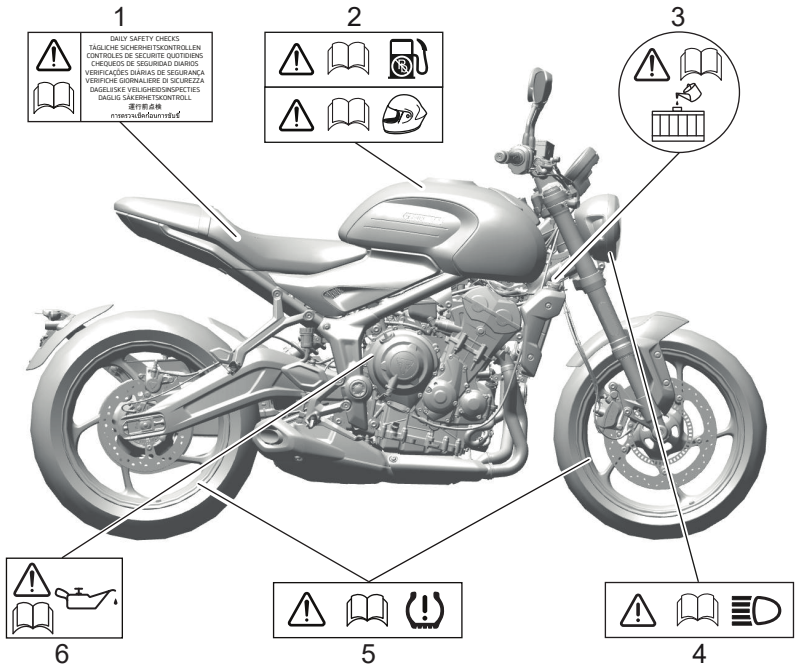

- | | |
|--|--|
| <ol style="list-style-type: none"> 1. Daily Safety Checks (page 143) 2. Unleaded Fuel (page 104) and Helmet (page 11) 3. Coolant - Radiator Filler Cap (page 181) | <ol style="list-style-type: none"> 4. Headlights (page 237) 5. Tire Pressure Monitoring System (TPMS) (if equipped) (page 217) 6. Engine Oil (page 174) |
|--|--|

WARNING LABELS

Trident 800

Left Hand Side

NOTICE

The labels detailed on this and the following pages draw your attention to important safety information in this handbook. Before riding, make sure that you have understood and complied with all the information to which these labels relate.

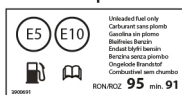
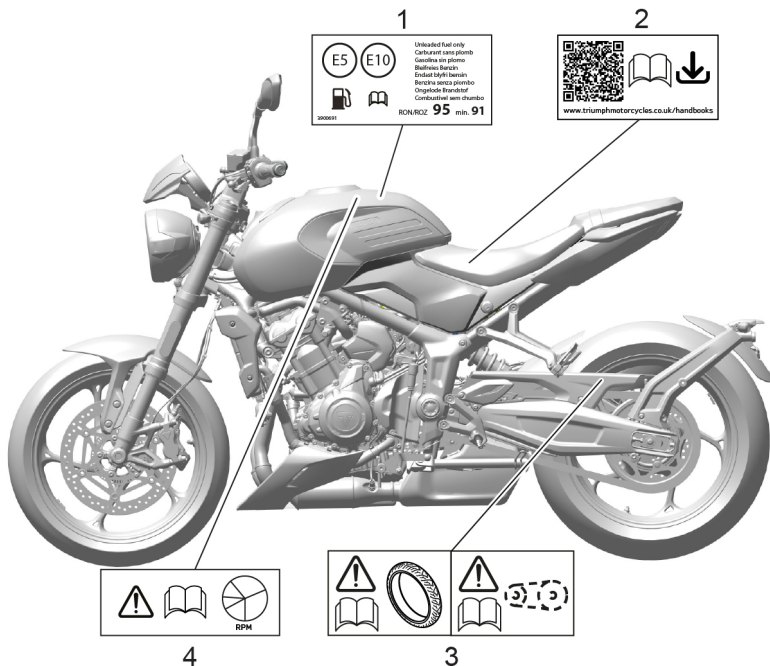

1. E5 and E10 Fuel (if equipped) (page 104)
2. Owner's Handbook Download Details (under seat)

3. Tires (page 216) and Drive Chain (page 188)
4. Breaking-In (page 142)

Right Hand Side

NOTICE

All warning labels and decals, with the exception of the Breaking-in label, are mounted on the motorcycle using a strong adhesive. In some cases, labels are installed prior to an application of paint lacquer. Therefore, any attempt to remove the warning labels will cause damage to the paintwork or bodywork.

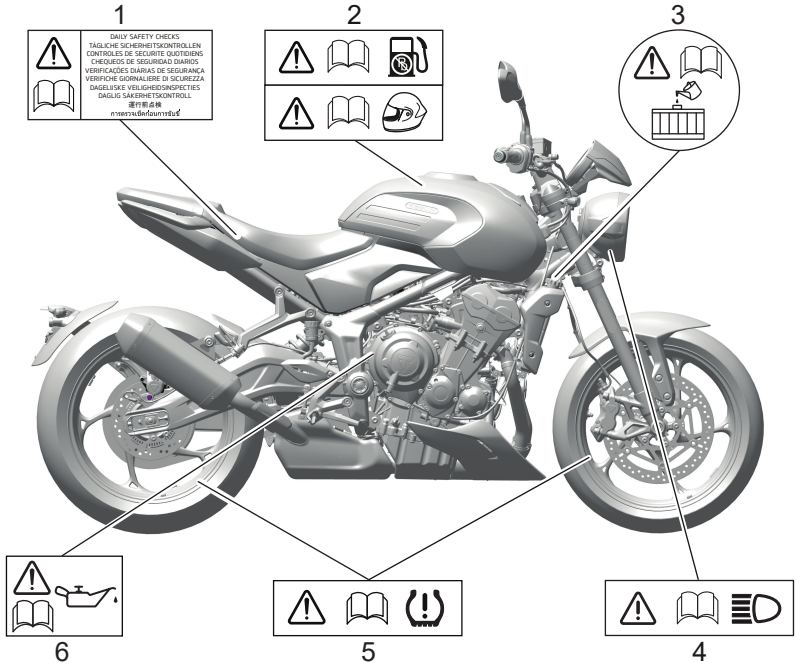

- | | |
|--|--|
| <ol style="list-style-type: none"> 1. Daily Safety Checks (page 143) 2. Unleaded Fuel (page 104) and Helmet (page 11) 3. Coolant - Radiator Filler Cap (page 181) | <ol style="list-style-type: none"> 4. Headlights (page 237) 5. Tire Pressure Monitoring System (TPMS) (if equipped) (page 217) 6. Engine Oil (page 174) |
|--|--|

WARNING LABELS

Tiger Sport 660

Left Hand Side

NOTICE

The labels detailed on this and the following pages draw your attention to important safety information in this handbook. Before riding, make sure that you have understood and complied with all the information to which these labels relate.

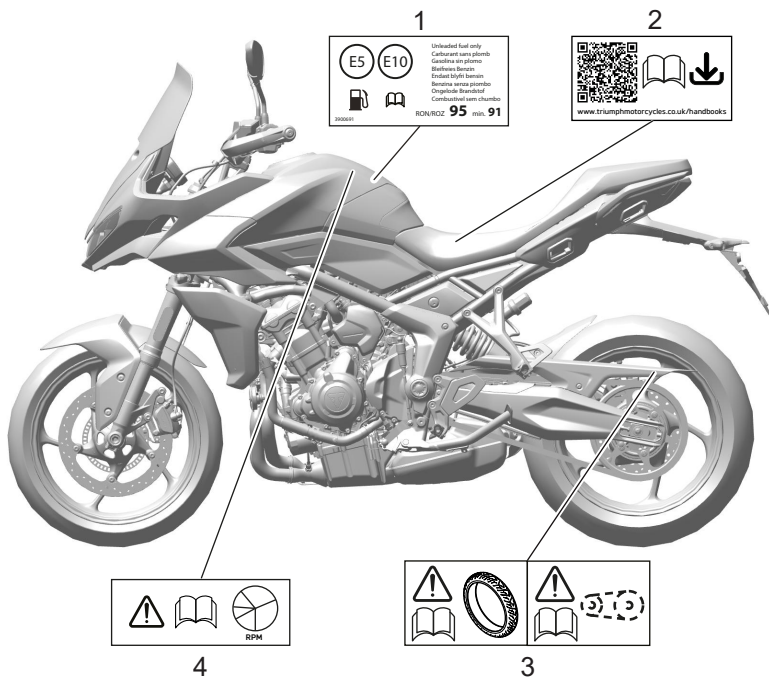

1. E5 and E10 Fuel (if equipped) (page 104)
2. Owner's Handbook Download Details (under seat)

3. Tires (page 216) and Drive Chain (page 188)
4. Breaking-In (page 142)

Right Hand Side

NOTICE

All warning labels and decals, with the exception of the Breaking-in label, are mounted on the motorcycle using a strong adhesive. In some cases, labels are installed prior to an application of paint lacquer. Therefore, any attempt to remove the warning labels will cause damage to the paintwork or bodywork.

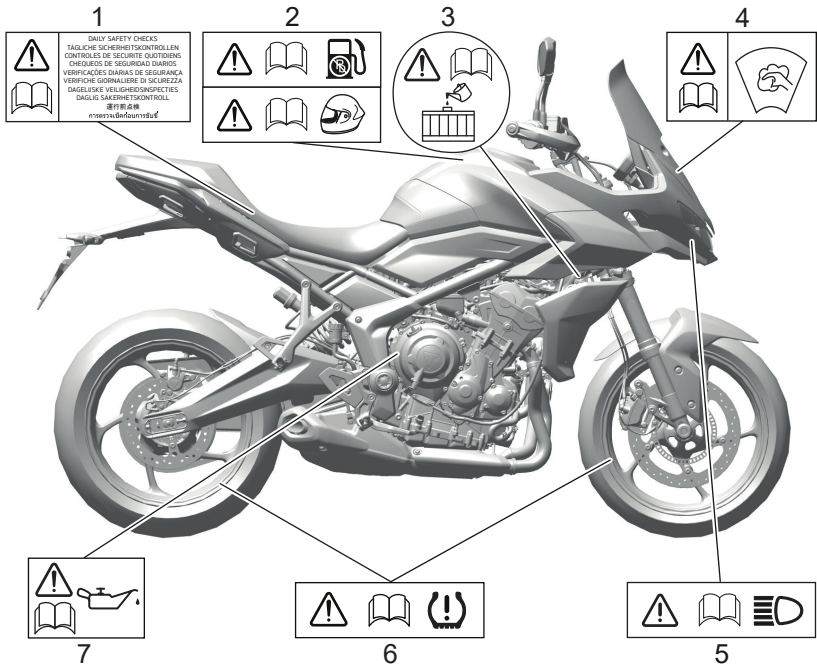

- | | |
|--|--|
| <ol style="list-style-type: none"> 1. Daily Safety Checks (page 143) 2. Unleaded Fuel (page 104) and Helmet (page 11) 3. Coolant - Radiator Filler Cap (page 181) 4. Windshield (if equipped) (page 248) | <ol style="list-style-type: none"> 5. Headlights (page 237) 6. Tire Pressure Monitoring System (TPMS) (if equipped) (page 217) 7. Engine Oil (page 174) |
|--|--|

WARNING LABELS

Tiger Sport 800

Left Hand Side

NOTICE

The labels detailed on this and the following pages draw your attention to important safety information in this handbook. Before riding, make sure that you have understood and complied with all the information to which these labels relate.

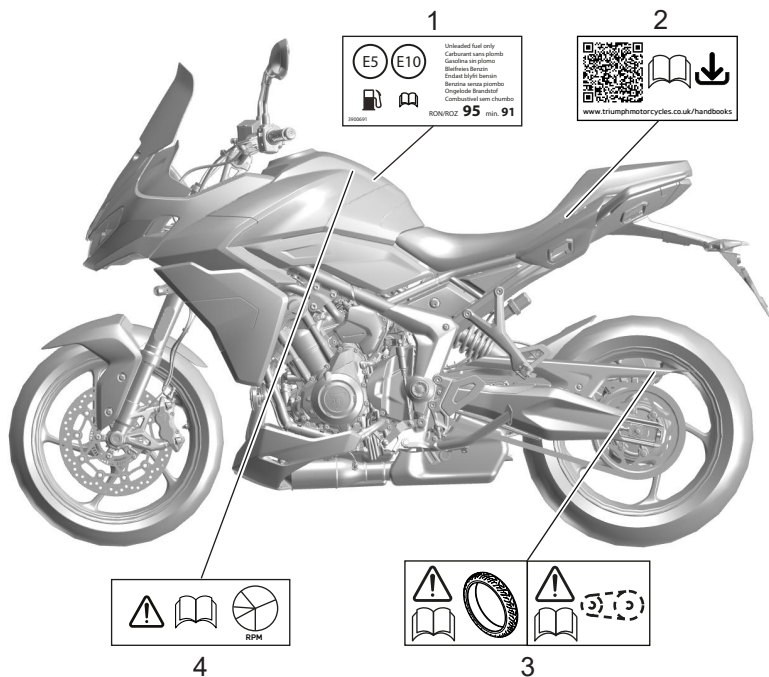

1. E5 and E10 Fuel (if equipped) (page 104)
2. Owner's Handbook Download Details (under seat)

3. Tires (page 216) and Drive Chain (page 188)
4. Breaking-In (page 142)

Right Hand Side

NOTICE

All warning labels and decals, with the exception of the Breaking-in label, are mounted on the motorcycle using a strong adhesive. In some cases, labels are installed prior to an application of paint lacquer. Therefore, any attempt to remove the warning labels will cause damage to the paintwork or bodywork.

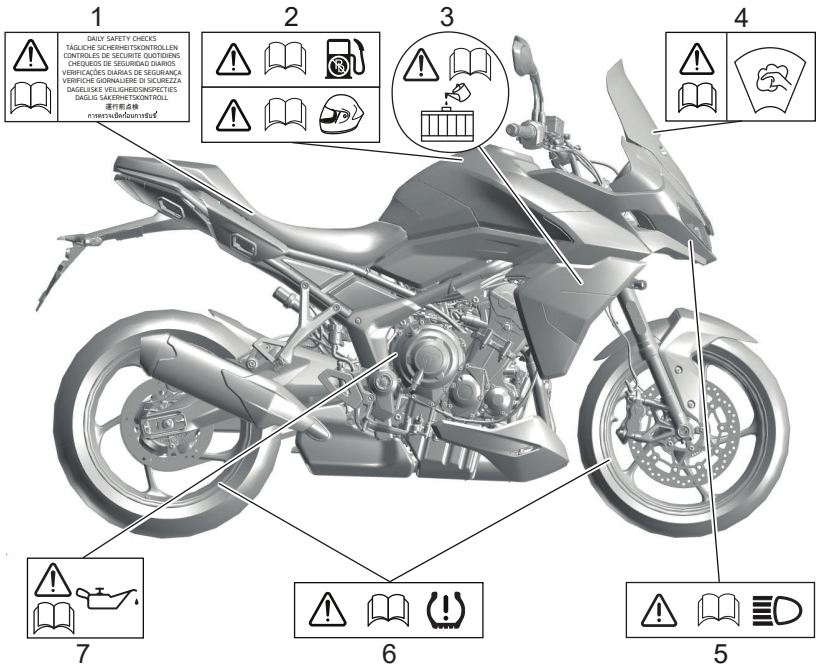

1. Daily Safety Checks (page 143)
2. Unleaded Fuel (page 104) and Helmet (page 11)
3. Coolant - Radiator Filler Cap (page 181)
4. Windshield (if equipped) (page 248)
5. Headlights (page 237)
6. Tire Pressure Monitoring System (TPMS) (if equipped) (page 217)
7. Engine Oil (page 174)

WARNING LABELS

Tiger Sport 800 Tour

Left Hand Side

NOTICE

The labels detailed on this and the following pages draw your attention to important safety information in this handbook. Before riding, make sure that you have understood and complied with all the information to which these labels relate.

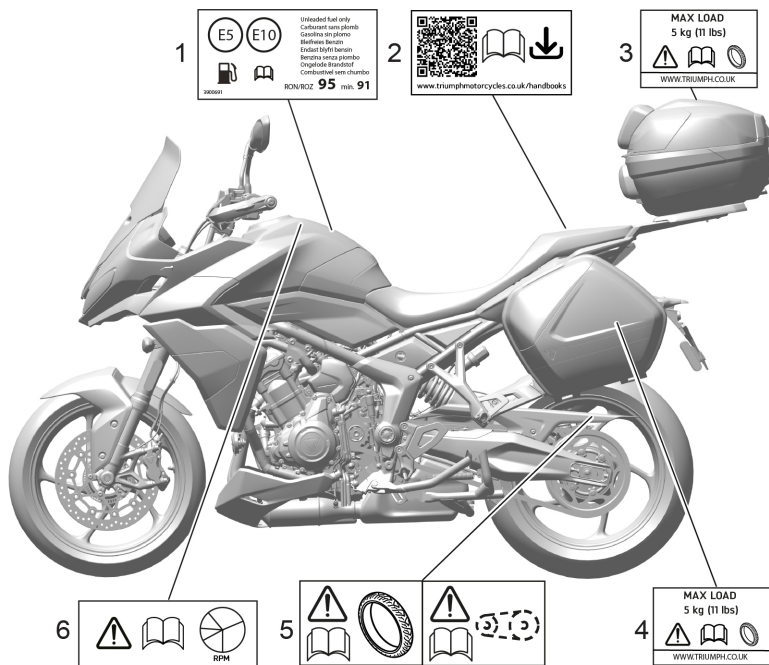

1. E5 and E10 Fuel (if equipped) (page 104)
2. Owner's Handbook Download Details (under seat)
3. Maximum Payload (inside top box)

4. Maximum Payload (inside panniers)
5. Tires (page 216) and Drive Chain (page 188)
6. Breaking-In (page 142)

Right Hand Side

NOTICE

All warning labels and decals, with the exception of the Breaking-in label, are mounted on the motorcycle using a strong adhesive. In some cases, labels are installed prior to an application of paint lacquer. Therefore, any attempt to remove the warning labels will cause damage to the paintwork or bodywork.

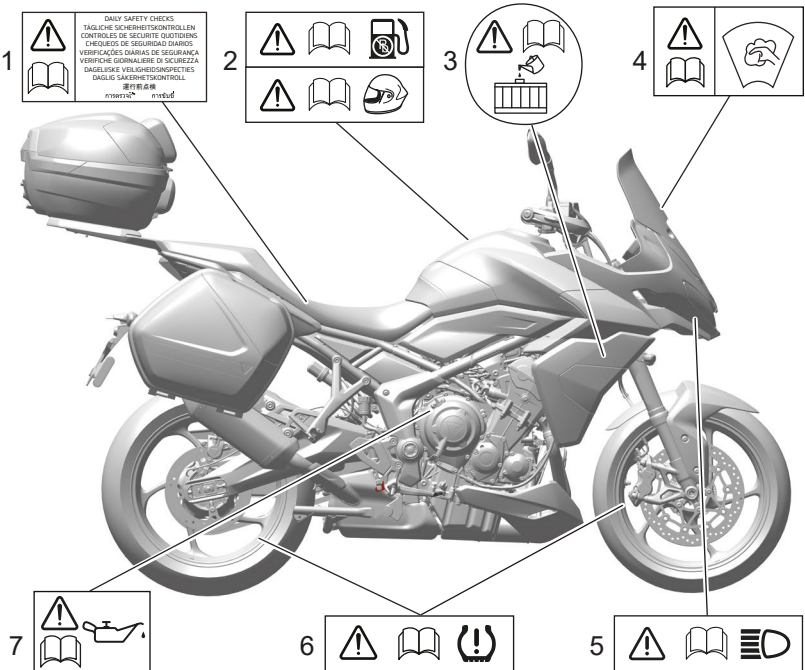

1. Daily Safety Checks (page 143)
2. Unleaded Fuel (page 104) and Helmet (page 11)
3. Coolant - Radiator Filler Cap (page 181)
4. Windshield (if equipped) (page 248)
5. Headlights (page 237)
6. Tire Pressure Monitoring System (TPMS) (if equipped) (page 217)
7. Engine Oil (page 174)

WARNING LABELS

Daytona 660

Left Hand Side

NOTICE

The labels detailed on this and the following pages draw your attention to important safety information in this handbook. Before riding, make sure that you have understood and complied with all the information to which these labels relate.

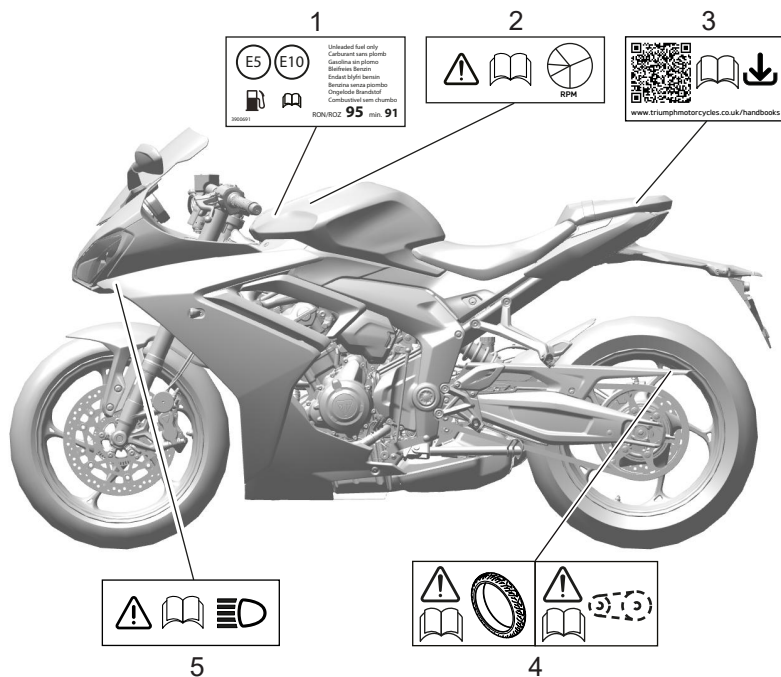

1. E5 and E10 Fuel (if equipped) (page 104)
2. Breaking-In (page 142)
3. Owner's Handbook Download Details (under seat)

4. Tires (page 216) and Drive Chain (page 188)
5. Headlights (page 237)

Right Hand Side

NOTICE

All warning labels and decals, with the exception of the Breaking-in label, are mounted on the motorcycle using a strong adhesive. In some cases, labels are installed prior to an application of paint lacquer. Therefore, any attempt to remove the warning labels will cause damage to the paintwork or bodywork.

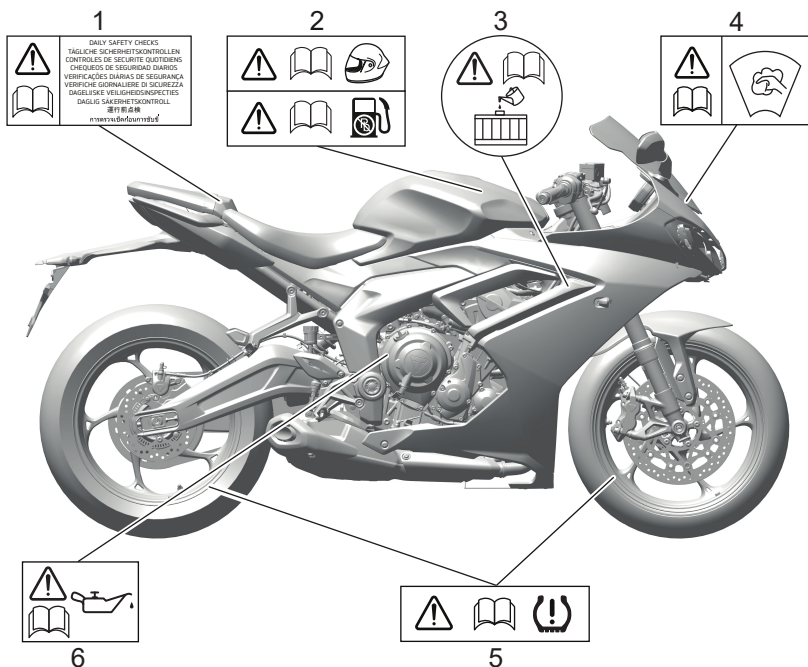

1. Daily Safety Checks (page 143)
2. Helmet (page 11) and Unleaded Fuel (page 104)
3. Coolant - Radiator Filler Cap (page 181)
4. Windshield (if equipped) (page 248)
5. Tire Pressure Monitoring System (TPMS) (if equipped) (page 217)
6. Engine Oil (page 174)

Trident 660 and Trident 660 - Triple Tribute

Trident 660 shown

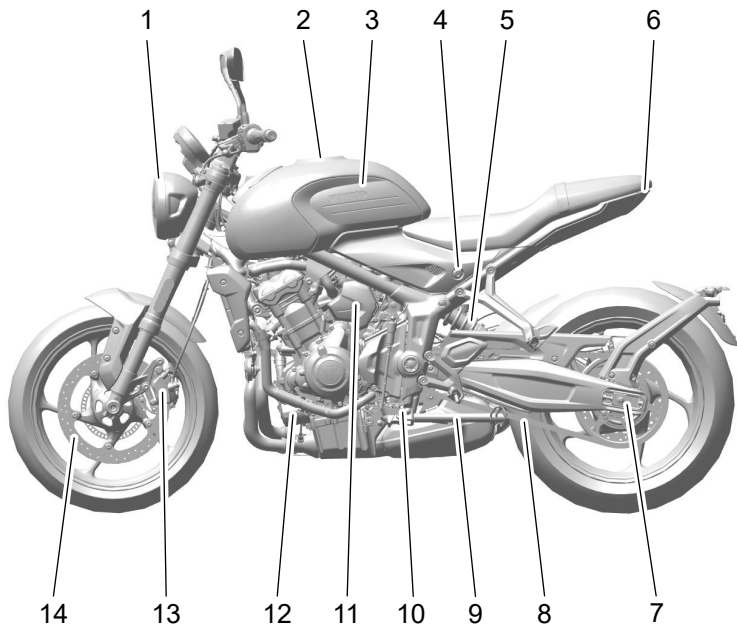
Left Hand Side

- | | |
|-------------------------|---|
| 1. Headlight | 9. Side stand |
| 2. Fuel filler cap | 10. Gear shift pedal |
| 3. Fuel tank | 11. Coolant expansion tank |
| 4. Seat lock | 12. Oil filter (behind belly pan for Trident 660 - Triple Tribute only) |
| 5. Rear suspension unit | 13. Front brake caliper |
| 6. Tail light | 14. Front brake disc |
| 7. Drive chain adjuster | |
| 8. Drive chain | |

Right Hand Side

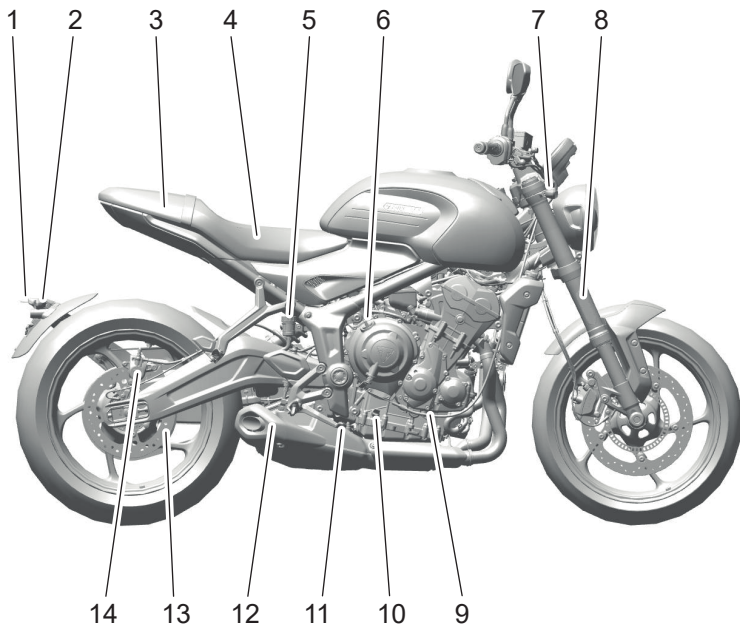

- | | |
|-------------------------------|-------------------------------|
| 1. License plate light | 8. Front fork |
| 2. Rear turn signal | 9. Clutch cable |
| 3. Allen key (under seat) | 10. Engine oil level dipstick |
| 4. Battery (under seat) | 11. Rear brake pedal |
| 5. Rear brake fluid reservoir | 12. Muffler |
| 6. Oil filler cap | 13. Rear brake disc |
| 7. Front turn signal | 14. Rear brake caliper |

Trident 800

Left Hand Side

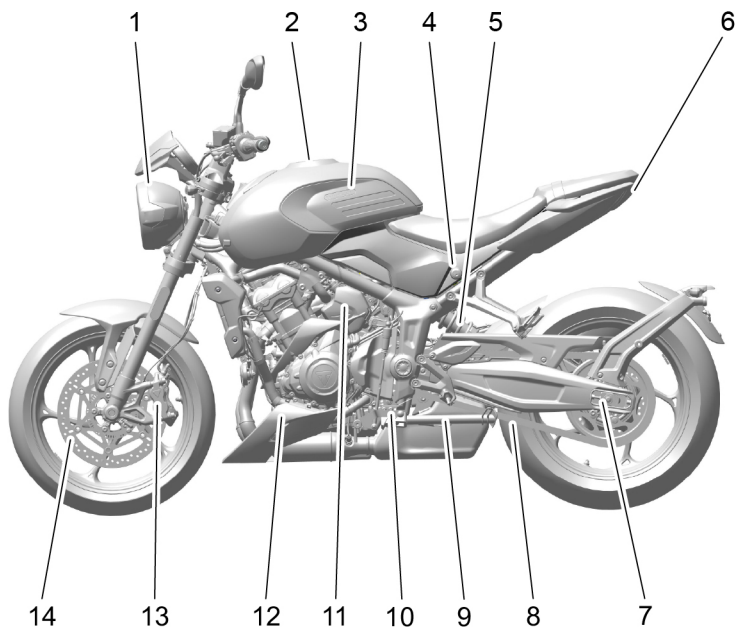

- | | |
|-------------------------|---------------------------------------|
| 1. Headlight | 8. Drive chain |
| 2. Fuel filler cap | 9. Side stand |
| 3. Fuel tank | 10. Gear shift pedal |
| 4. Seat lock | 11. Coolant expansion tank |
| 5. Rear suspension unit | 12. Oil filter (behind the belly pan) |
| 6. Tail light | 13. Front brake caliper |
| 7. Drive chain adjuster | 14. Front brake disc |

Right Hand Side

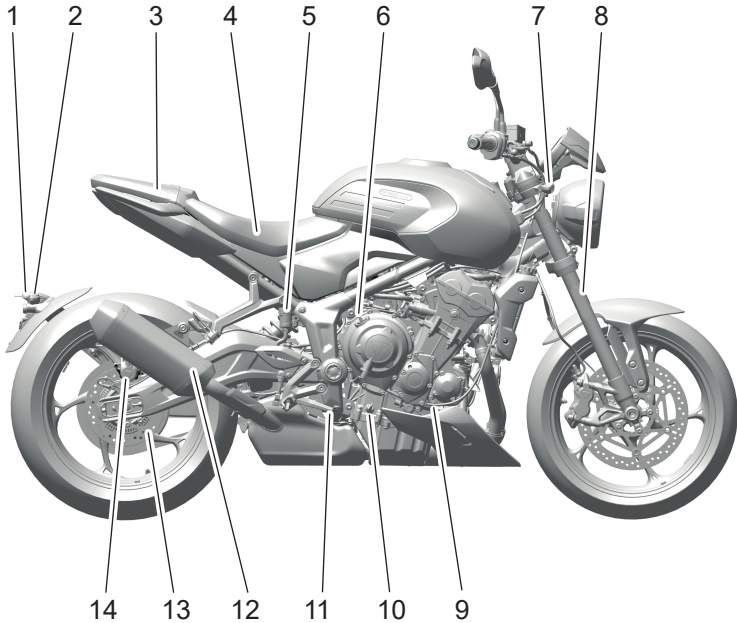

- | | |
|-------------------------------|-------------------------------|
| 1. License plate light | 8. Front fork |
| 2. Rear turn signal | 9. Clutch cable |
| 3. Allen key (under seat) | 10. Engine oil level dipstick |
| 4. Battery (under seat) | 11. Rear brake pedal |
| 5. Rear brake fluid reservoir | 12. Muffler |
| 6. Oil filler cap | 13. Rear brake disc |
| 7. Front turn signal | 14. Rear brake caliper |

Tiger Sport 660

Left Hand Side

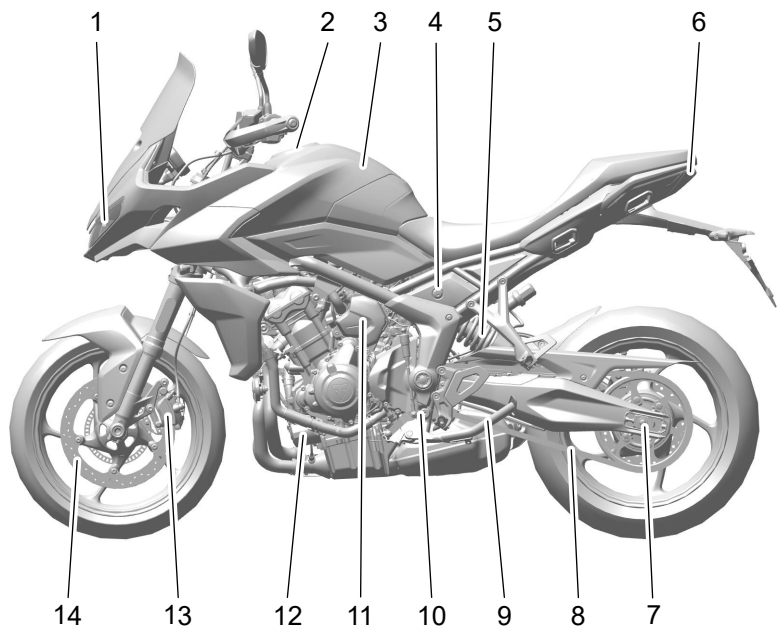

- 1. Headlight
- 2. Fuel filler cap
- 3. Fuel tank
- 4. Seat lock
- 5. Rear suspension unit
- 6. Tail light
- 7. Drive chain adjuster

- 8. Drive chain
- 9. Side stand
- 10. Gear shift pedal
- 11. Coolant expansion tank
- 12. Oil filter
- 13. Front brake caliper
- 14. Front brake disc

Right Hand Side

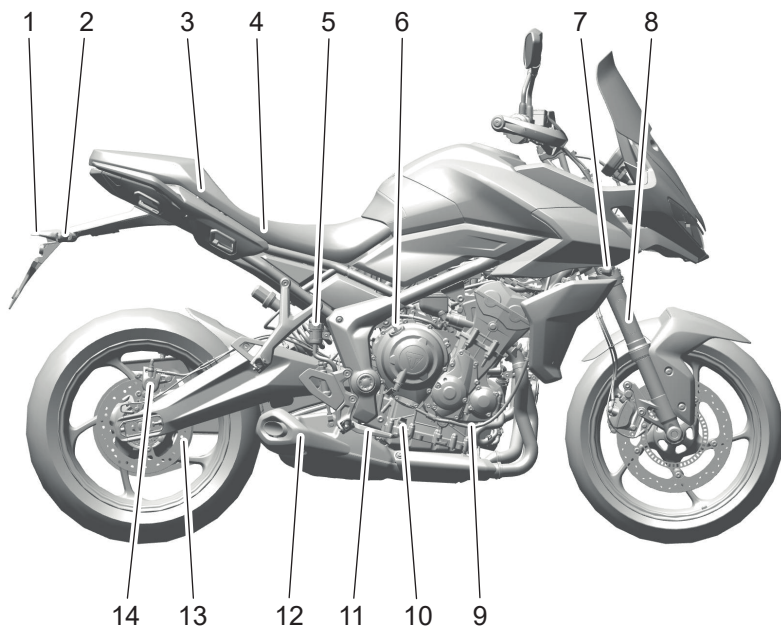

- | | |
|-------------------------------|-------------------------------|
| 1. License plate light | 8. Front fork |
| 2. Rear turn signal | 9. Clutch cable |
| 3. Allen key (under seat) | 10. Engine oil level dipstick |
| 4. Battery (under seat) | 11. Rear brake pedal |
| 5. Rear brake fluid reservoir | 12. Muffler |
| 6. Oil filler cap | 13. Rear brake disc |
| 7. Front turn signal | 14. Rear brake caliper |

Tiger Sport 800

Left Hand Side

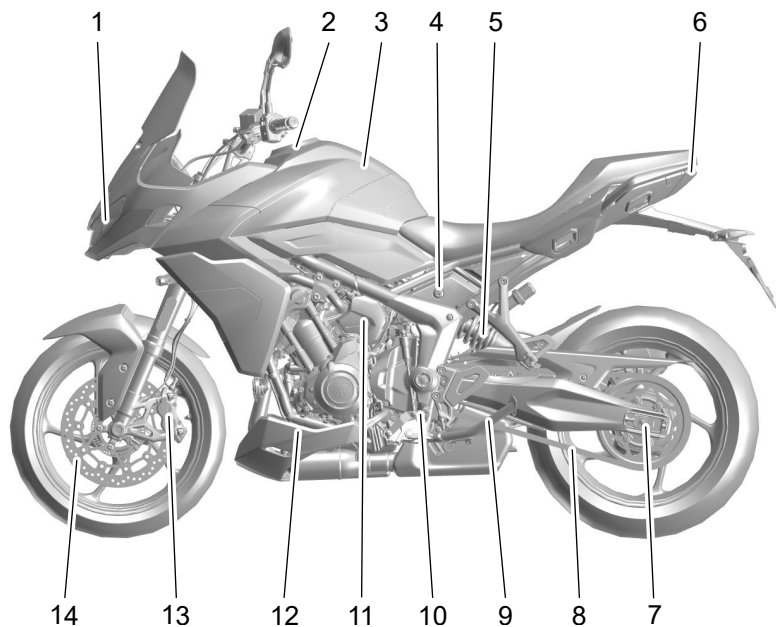

- 1. Headlight
- 2. Fuel filler cap
- 3. Fuel tank
- 4. Seat lock
- 5. Rear suspension unit
- 6. Tail light
- 7. Drive chain adjuster

- 8. Drive chain
- 9. Side stand
- 10. Gear shift pedal
- 11. Coolant expansion tank
- 12. Oil filter (behind belly pan)
- 13. Front brake caliper
- 14. Front brake disc

Right Hand Side

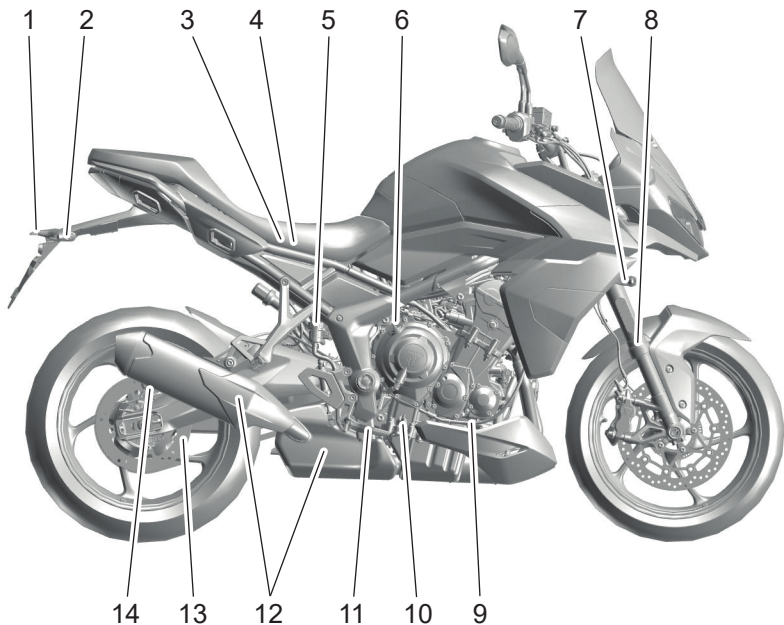

- | | |
|-------------------------------|-------------------------------|
| 1. License plate light | 8. Front fork |
| 2. Rear turn signal | 9. Clutch cable |
| 3. Allen key (under seat) | 10. Engine oil level dipstick |
| 4. Battery (under seat) | 11. Rear brake pedal |
| 5. Rear brake fluid reservoir | 12. Mufflers |
| 6. Oil filler cap | 13. Rear brake disc |
| 7. Front turn signal | 14. Rear brake caliper |

Tiger Sport 800 Tour

Left Hand Side

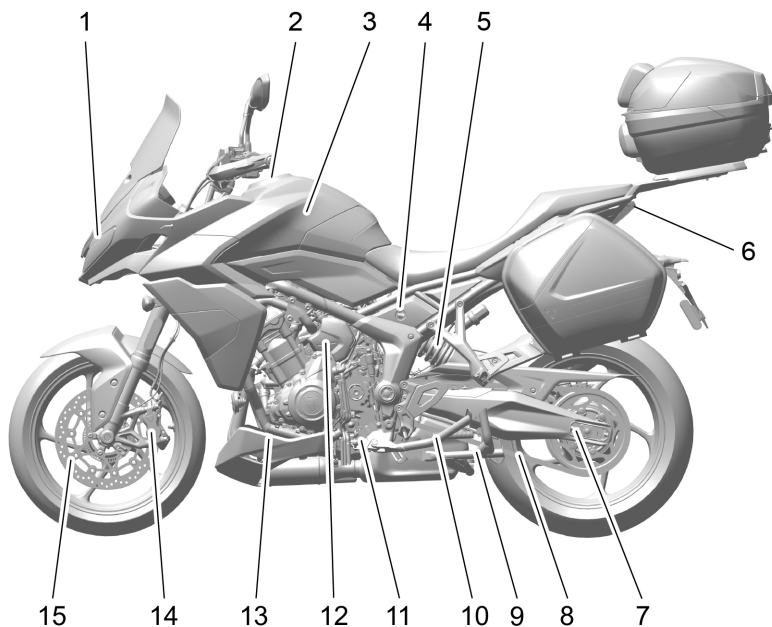

- | | |
|-------------------------|-----------------------------------|
| 1. Headlight | 9. Drive chain |
| 2. Fuel filler cap | 10. Side stand |
| 3. Fuel tank | 11. Gear shift pedal |
| 4. Seat lock | 12. Coolant expansion tank |
| 5. Rear suspension unit | 13. Oil filter (behind belly pan) |
| 6. Tail light | 14. Front brake caliper |
| 7. Drive chain adjuster | 15. Front brake disc |
| 8. Center stand | |

Right Hand Side

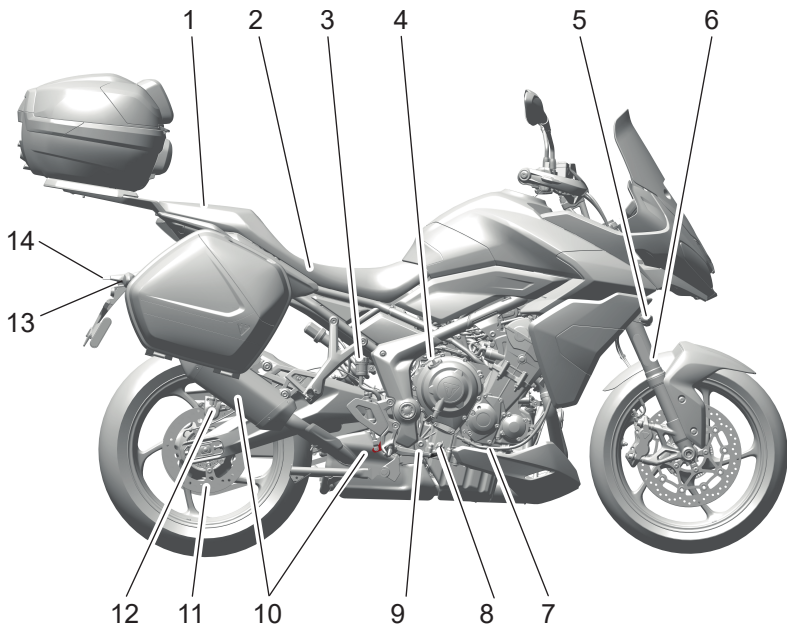

1. Allen key (under seat)
2. Battery (under seat)
3. Rear brake fluid reservoir
4. Oil filler cap
5. Front turn signal
6. Front fork
7. Clutch cable
8. Engine oil level dipstick
9. Rear brake pedal
10. Mufflers
11. Rear brake disc
12. Rear brake caliper
13. Rear turn signal
14. License plate light

Daytona 660

Left Hand Side

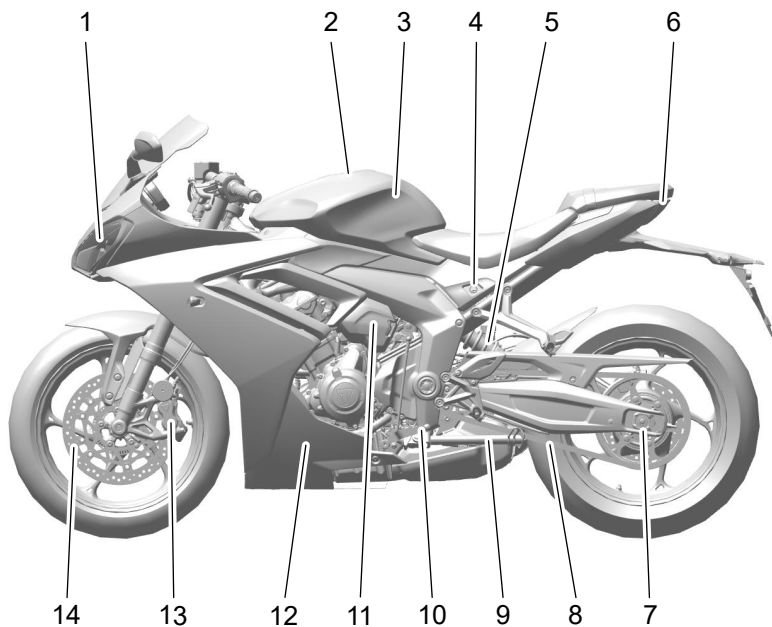

- 1. Headlight
- 2. Fuel filler cap
- 3. Fuel tank
- 4. Seat lock
- 5. Rear suspension unit
- 6. Tail light
- 7. Drive chain adjuster

- 8. Drive chain
- 9. Side stand
- 10. Gear shift pedal
- 11. Coolant expansion tank
- 12. Oil filter (behind fairing)
- 13. Front brake caliper
- 14. Front brake disc

Right Hand Side

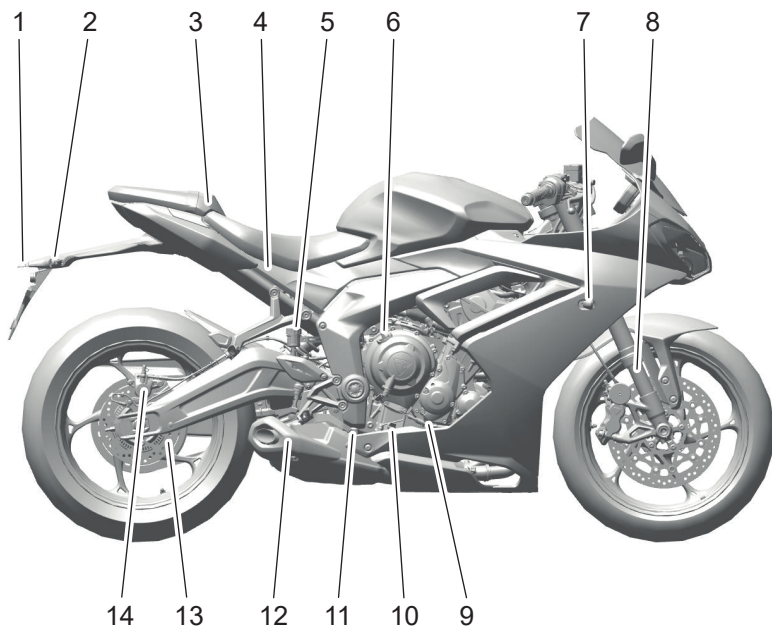

- | | |
|-------------------------------|-------------------------------|
| 1. License plate light | 8. Front fork |
| 2. Rear turn signal | 9. Clutch cable |
| 3. Allen key (under seat) | 10. Engine oil level dipstick |
| 4. Battery (under seat) | 11. Rear brake pedal |
| 5. Rear brake fluid reservoir | 12. Muffler |
| 6. Oil filler cap | 13. Rear brake disc |
| 7. Front turn signal | 14. Rear brake caliper |

Rider View Parts Identification

Trident 660 and Trident 660 - Triple Tribute

Trident 660 shown

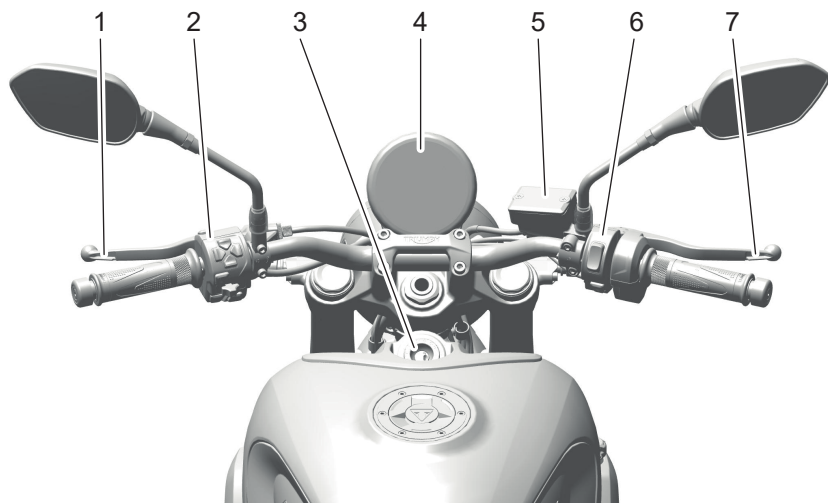

- 1. Clutch lever
- 2. Left hand switch housing, see page 100
- 3. Ignition switch
- 4. Instruments, see page 53
- 5. Front brake fluid reservoir
- 6. Right hand switch housing, see page 99
- 7. Front brake lever

Trident 800

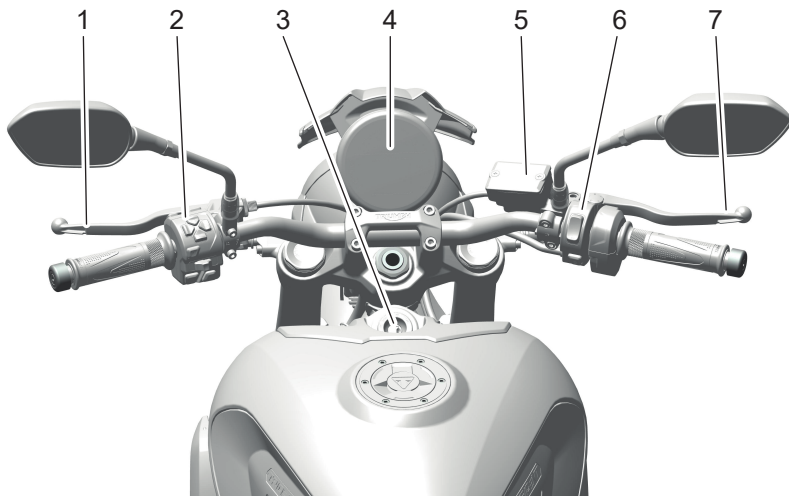

1. Clutch lever
2. Left hand switch housing, see page 100
3. Ignition switch
4. Instruments, see page 54
5. Front brake fluid reservoir
6. Right hand switch housing, see page 99
7. Front brake lever

Tiger Sport 660

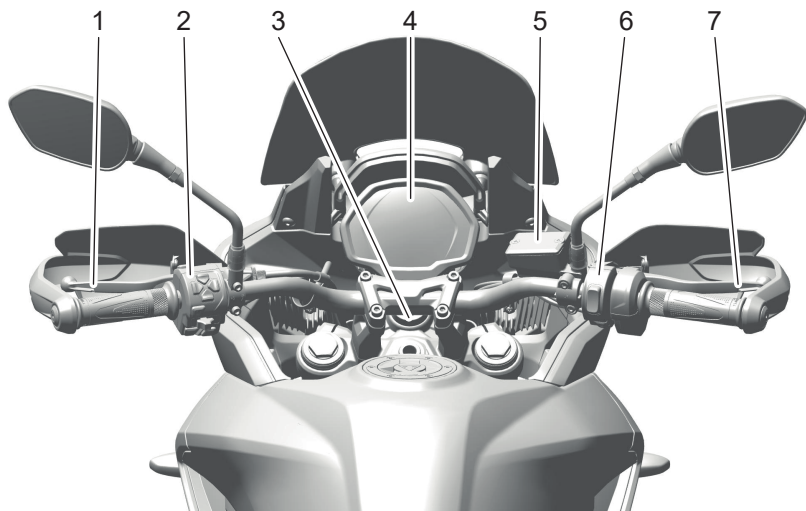

- 1. Clutch lever
- 2. Left hand switch housing, see page 100
- 3. Ignition switch
- 4. Instruments, see page 55

- 5. Front brake fluid reservoir
- 6. Right hand switch housing, see page 99
- 7. Front brake lever

Tiger Sport 800

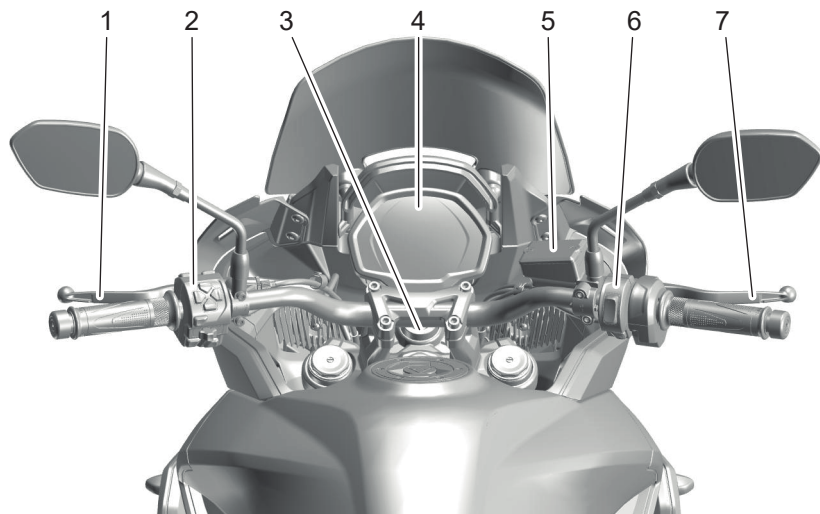

1. Clutch lever
2. Left hand switch housing, see page 100
3. Ignition switch
4. Instruments, see page 56
5. Front brake fluid reservoir
6. Right hand switch housing, see page 99
7. Front brake lever

Tiger Sport 800 Tour

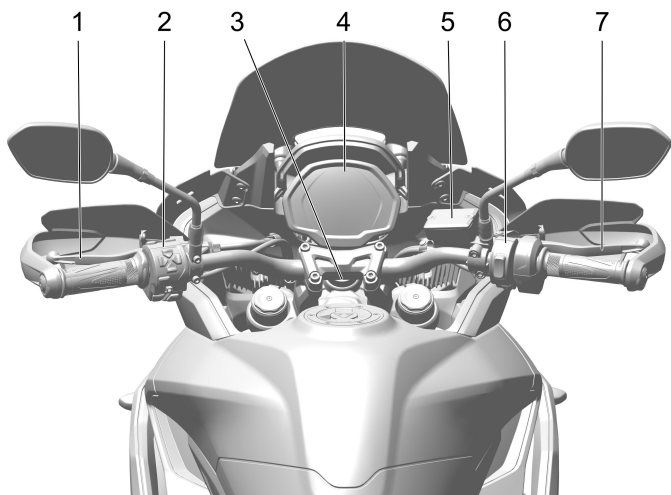

- 1. Clutch lever
- 2. Left hand switch housing, see page 100
- 3. Ignition switch
- 4. Instruments, see page 56
- 5. Front brake fluid reservoir
- 6. Right hand switch housing, see page 99
- 7. Front brake lever

Daytona 660

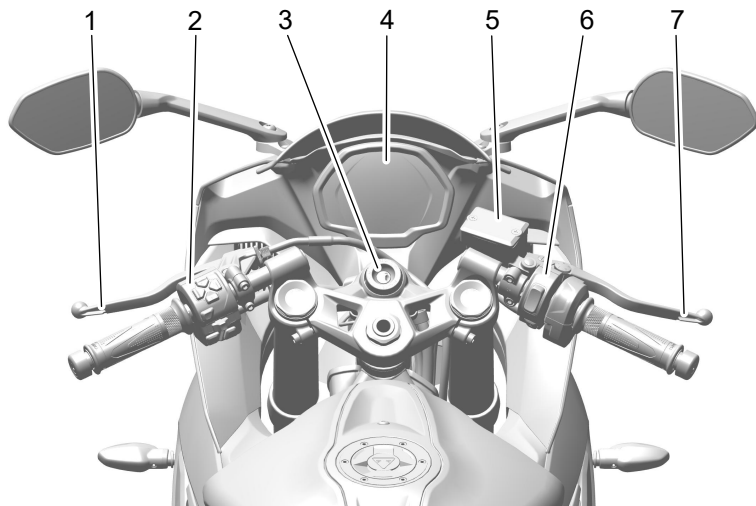

1. Clutch lever
2. Left hand switch housing, see page 100
3. Ignition switch
4. Instruments, see page 57
5. Front brake fluid reservoir
6. Right hand switch housing, see page 99
7. Front brake lever

This page intentionally left blank

Vehicle Identification Number (VIN)

The Vehicle Identification Number (VIN) is stamped into the steering head.

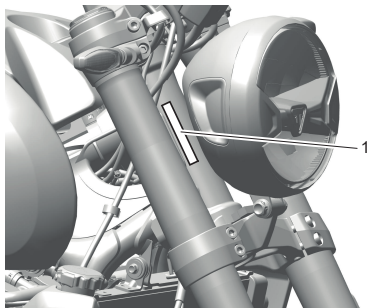

1. VIN stamp (Trident 660 shown)

Record the VIN in the space provided in the Motorcycle Service Handbook.

Trident 660, Trident 660 - Triple Tribute, Trident 800, Tiger Sport 800 and Tiger Sport 800 Tour

The VIN is also shown on a label attached to the steering head.

Tiger Sport 660

The VIN is also displayed on a label attached to the left hand side of the frame, adjacent to the side panel.

Daytona 660

The VIN is also displayed on a label attached to the left hand side of the frame, adjacent to the passenger footrest hanger.

Engine Serial Number

The engine serial number is stamped on the upper engine crankcase, directly above the clutch cover.

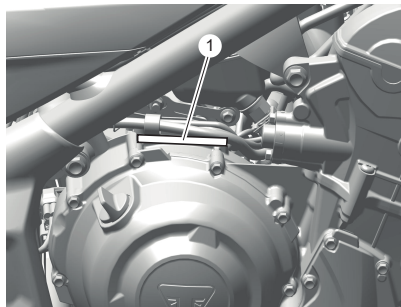

1. Engine serial number (Trident 660 shown)

Record the engine serial number in the space provided in the Motorcycle Service Handbook.

This page intentionally left blank

Table of Contents

Instruments Display - Trident 660 and Trident 660 - Triple Tribute.....	53
Instruments Display - Trident 800	54
Instruments Display - Tiger Sport 660	55
Instruments Display - Tiger Sport 800.....	56
Instruments Display - Daytona 660.....	57
Warning Lights	58
Engine Management System Malfunction Indicator Light (MIL).....	58
Low Oil Pressure Warning Light	59
High Coolant Temperature Warning Light	59
Engine Immobilizer / Alarm Indicator Light.....	60
Anti-lock Braking System (ABS) Warning Light.....	60
Cruise Control Indicator Light	61
Traction Control (TC) Indicator Light	61
Traction Control (TC) Disabled Warning Light.....	62
Turn signal Light	62
Hazard Warning Lights.....	62
High Beam Indicator Light	62
Daytime Running Lights (DRL) Indicator Light (if equipped).....	63
Neutral Indicator Light.....	63
Low Fuel Indicator Light	63
Tire Pressure Warning Light (if equipped with TPMS).....	63
Low Battery Warning Light.....	64
General Warning Symbol.....	64
Warning and Information Messages.....	64
Speedometer	67
Odometer	67
Tachometer	68
Fuel Gauge	68

INSTRUMENTS

Coolant Temperature Gauge	69
Ambient Air Temperature	70
Frost Symbol	70
Gear Position	71
Display Navigation.....	71
Riding Modes	72
Rain Mode.....	72
Road Mode	73
Sport Mode.....	73
Riding Mode Selection	74
Information Tray.....	75
Trip Meters.....	76
Fuel Status.....	76
Tire Pressure Monitoring System (TPMS) (if equipped)	77
Coolant.....	77
Service Interval.....	78
Brightness.....	78
Gear	79
Tachometer	79
Main Menu	80
Riding Modes	81
Riding Mode Configuration	82
Bike Setup Menu	83
Trip Setup Menu	85
Display Setup Menu.....	87
Reset to Defaults.....	92
Bluetooth®.....	92

Instruments Display - Trident 660 and Trident 660 - Triple Tribute

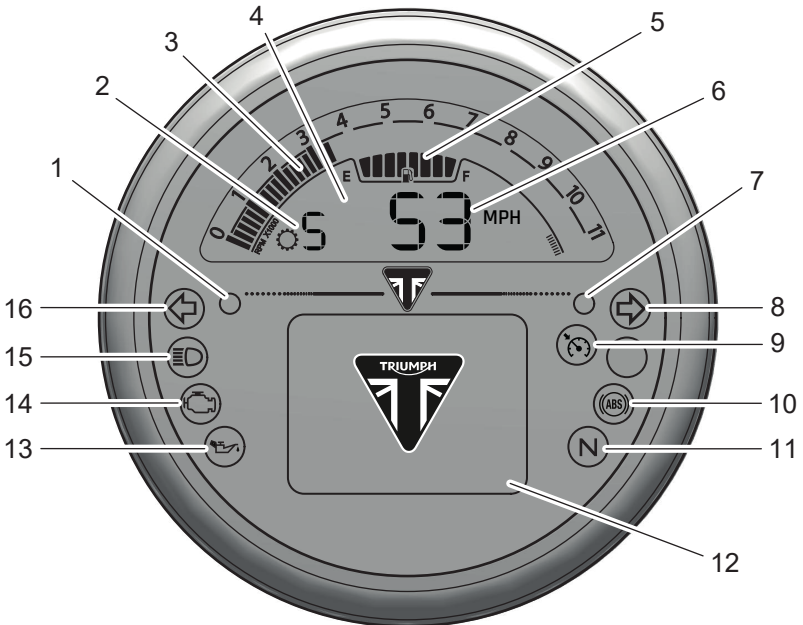

- | | |
|--|---|
| 1. Alarm/immobilizer | 10. ABS warning light |
| 2. Gear position | 11. Neutral indicator light |
| 3. Tachometer | 12. TFT screen/information tray |
| 4. LCD screen | 13. Oil pressure warning light |
| 5. Fuel gage | 14. Engine management Malfunction Indicator Light (MIL) |
| 6. Speedometer | 15. High beam indicator light |
| 7. Ambient light sensor | 16. Left hand turn signal and hazard warning light |
| 8. Right hand turn signal and hazard warning light | |
| 9. Cruise control indicator light | |

INSTRUMENTS

Instruments Display - Trident 800

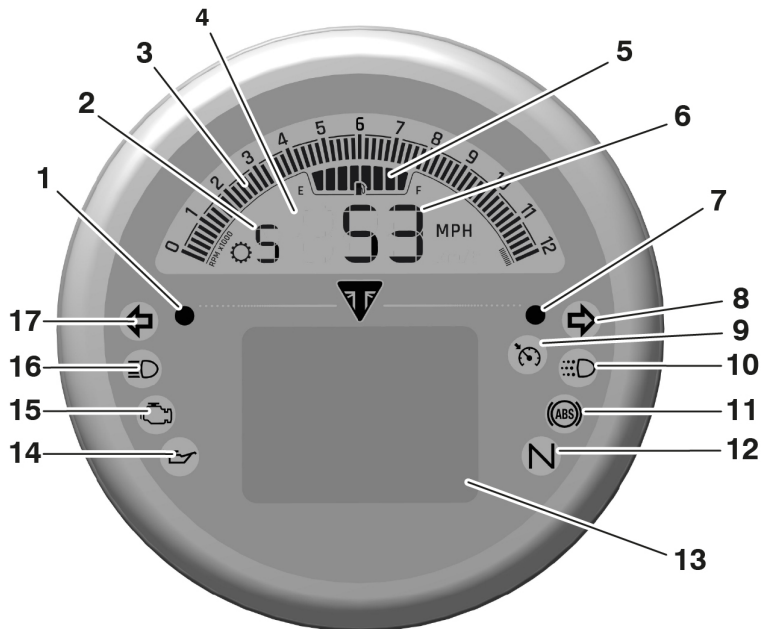

- | | |
|--|---|
| 1. Alarm/immobilizer | 10. Daytime Running Lights (DRL) indicator light |
| 2. Gear position | 11. ABS warning light |
| 3. Tachometer | 12. Neutral indicator light |
| 4. LCD screen | 13. TFT screen/information tray |
| 5. Fuel gage | 14. Oil pressure warning light |
| 6. Speedometer | 15. Engine management Malfunction Indicator Light (MIL) |
| 7. Ambient light sensor | 16. High beam indicator light |
| 8. Right hand turn signal and hazard warning light | 17. Left hand turn signal and hazard warning light |
| 9. Cruise control indicator light | |

Instruments Display - Tiger Sport 660

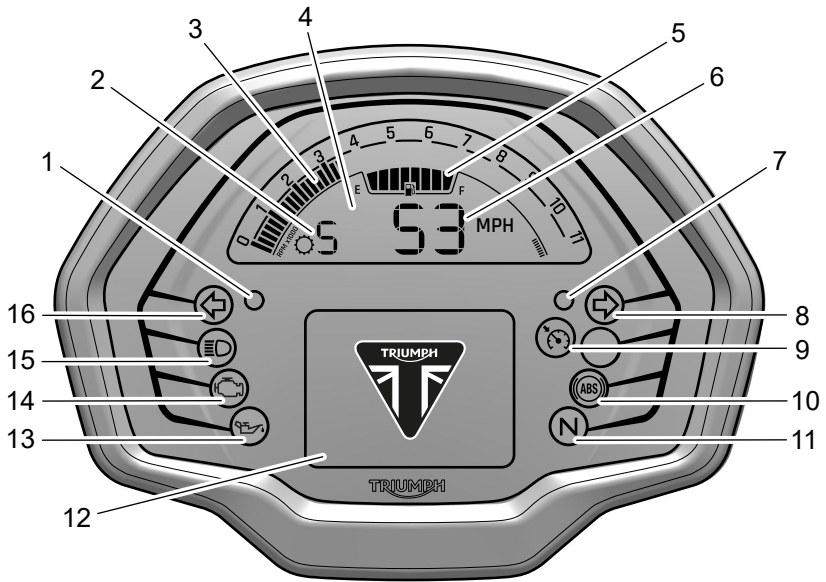

- | | |
|--|---|
| 1. Alarm/immobilizer | 10. ABS warning light |
| 2. Gear position | 11. Neutral indicator light |
| 3. Tachometer | 12. TFT screen/information tray |
| 4. LCD screen | 13. Oil pressure warning light |
| 5. Fuel gage | 14. Engine management Malfunction Indicator Light (MIL) |
| 6. Speedometer | 15. High beam indicator light |
| 7. Ambient light sensor | 16. Left hand turn signal and hazard warning light |
| 8. Right hand turn signal and hazard warning light | |
| 9. Cruise control indicator light | |

INSTRUMENTS

Instruments Display - Tiger Sport 800

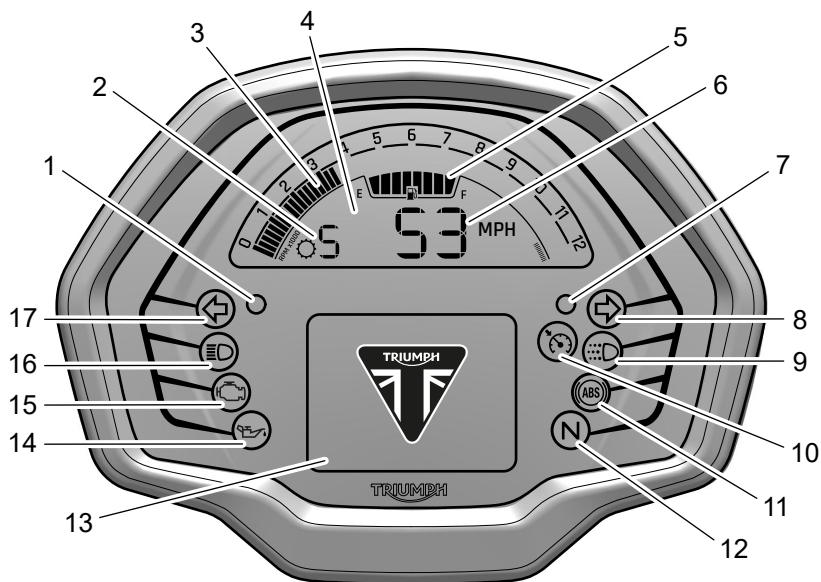

- | | |
|--|---|
| 1. Alarm/immobilizer | 10. Cruise control indicator light |
| 2. Gear position | 11. ABS warning light |
| 3. Tachometer | 12. Neutral indicator light |
| 4. LCD screen | 13. TFT screen/information tray |
| 5. Fuel gage | 14. Oil pressure warning light |
| 6. Speedometer | 15. Engine management Malfunction Indicator Light (MIL) |
| 7. Ambient light sensor | 16. High beam indicator light |
| 8. Right hand turn signal and hazard warning light | 17. Left hand turn signal and hazard warning light |
| 9. Daytime Running Lights (DRL) indicator light | |

Instruments Display - Daytona 660

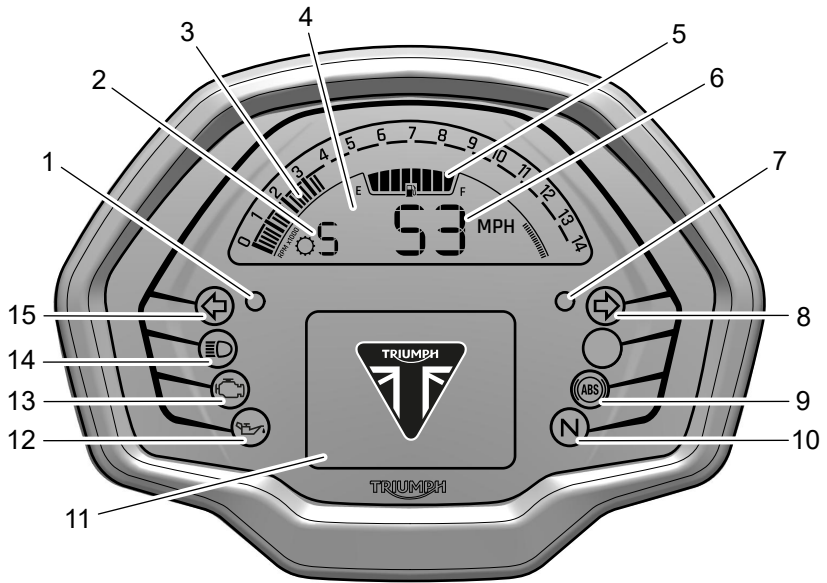

- | | |
|--|---|
| 1. Alarm/immobilizer | 9. ABS warning light |
| 2. Gear position | 10. Neutral indicator light |
| 3. Tachometer | 11. TFT screen/information tray |
| 4. LCD screen | 12. Oil pressure warning light |
| 5. Fuel gauge | 13. Engine management Malfunction Indicator Light (MIL) |
| 6. Speedometer | 14. High beam indicator light |
| 7. Ambient light sensor | 15. Left hand turn signal and hazard warning light |
| 8. Right hand turn signal and hazard warning light | |

Warning Lights

NOTICE

If a red warning light is shown, the motorcycle must be stopped immediately.

If an amber warning light is shown, the motorcycle does not need to be stopped immediately.

Always read any warning messages and rectify the issue.

When the ignition is switched on, the instrument warning lights will illuminate for 1.5 seconds and will then go off (except those which remain on until the engine starts, as described in the following pages).

For additional warning information, see page 64.

Engine Management System Malfunction Indicator Light (MIL)

⚠ WARNING

Reduce speed and do not continue to ride for longer than is necessary with the Malfunction Indicator Light (MIL) illuminated. The fault may affect engine performance, exhaust emissions and fuel consumption.

The fault must be checked and rectified by a competent person with the specialist knowledge and technical understanding of motorcycles, such as an authorized Triumph dealer.

Reduced engine performance could cause a dangerous riding condition, leading to loss of motorcycle control which could result in serious injury or death.



The Malfunction Indicator Light (MIL) for the engine management system illuminates when the ignition is switched ON (to indicate that it is working), but should not become illuminated when the engine is running.

If the engine is running and there is a fault with the engine management system, the MIL will be illuminated and the general warning symbol will flash. In such circumstances, the engine management system may switch to 'limp-home' mode so that the journey may be completed, if the fault is not so severe that the engine will not run.

If the MIL flashes when the ignition is switched ON, contact an authorized Triumph dealer as soon as possible to have the situation rectified. In these circumstances the engine will not start.

Low Oil Pressure Warning Light

NOTICE

If the engine oil pressure is too low, the low oil pressure warning light will illuminate.

If the low oil pressure indicator remains on, stop the engine immediately and investigate the situation.

Running the engine with low oil pressure will cause severe engine damage.



With the engine running, if the engine oil pressure becomes dangerously low, the low oil pressure warning light will illuminate. The low oil pressure warning light will also illuminate if the ignition is switched ON without running the engine.

High Coolant Temperature Warning Light

NOTICE

Stop the engine immediately if the high coolant temperature warning light illuminates.

Do not restart the engine until the fault has been rectified.

Severe engine damage will result from running the engine when the high coolant temperature warning light is illuminated.



With the engine running, if the engine coolant temperature becomes dangerously high, the high coolant temperature warning light will illuminate.

INSTRUMENTS

Engine Immobilizer / Alarm Indicator Light



This motorcycle is equipped with an engine immobilizer, which is activated when the ignition switch is turned to the OFF position.

Not Equipped With Alarm

When the ignition switch is turned to the OFF position, the engine immobilizer/alarm light will flash on and off for 24 hours to show that the engine immobilizer is on. When the ignition switch is turned to the ON position, the engine immobilizer and the indicator light will be off.

If the indicator light remains on, it indicates that the engine immobilizer has a malfunction that requires investigation. The fault must be checked and rectified by a competent person with the specialist knowledge and technical understanding of motorcycles, such as an authorized Triumph dealer.

Equipped With Alarm

The engine immobilizer/alarm light will only illuminate when the conditions described in the genuine Triumph accessory alarm instructions are met.

Anti-lock Braking System (ABS) Warning Light

WARNING

If the Anti-lock Brake System (ABS) is not functioning, the brake system will continue to function as a non-ABS equipped brake system. Do not continue to ride for longer than is necessary with the ABS warning light illuminated.

The fault must be checked and rectified by a competent person with the specialist knowledge and technical understanding of motorcycles, such as an authorized Triumph dealer.

Braking too hard will cause the wheels to lock, leading to loss of motorcycle control, which could result in serious injury or death.

NOTICE

Traction control will not function if there is a malfunction with the ABS. The warning lights for the ABS, traction control and the MIL will be illuminated.



When the ignition switch is turned to the ON position, it is normal that the ABS warning light will flash on and off. The light will continue to flash after engine start-up until the motorcycle first reaches a speed exceeding 6 mph (10 km/h) when it will go off.

The warning light should not illuminate again until the engine is restarted, unless there is a fault.

If the warning light becomes illuminated at any time while riding, it indicates that the ABS has a malfunction that requires investigation.

Cruise Control Indicator Light



The cruise control (if equipped) can only be activated when the motorcycle is traveling at a speed between 19 to 100 mph (30 to 160 km/h) and is in 2nd gear or higher. When activated, the cruise control indicator light will be shown in green.

Traction Control (TC) Indicator Light

WARNING

If the traction control is not functioning, care must be taken when accelerating and cornering on wet/slippery road surfaces to avoid rear wheel spin. Do not continue to ride for longer than is necessary with the engine management system Malfunction Indicator Light (MIL) and traction control warning lights illuminated.

The fault must be checked and rectified by a competent person with the specialist knowledge and technical understanding of motorcycles, such as an authorized Triumph dealer.

Hard acceleration and cornering may cause the rear wheel to spin, leading to loss of motorcycle control which could result in serious injury or death.

NOTICE

Traction control will not function if there is a malfunction with the ABS. The warning lights for the ABS, traction control and the MIL will be illuminated.



The Traction Control (TC) indicator light is used to indicate that the traction control system is active and is working to limit rear wheel slip during periods of hard acceleration or under wet or slippery road conditions.

If traction control is switched on:

- ▼ Under normal riding conditions the TC indicator light will remain off.
- ▼ The TC indicator light will flash rapidly when the traction control system is working to limit rear wheel slip during periods of hard acceleration or under wet or slippery road conditions.

If traction control is switched off:

- ▼ The TC indicator light will not illuminate. Instead the TC disabled warning light will be illuminated.

Traction Control (TC) Disabled Warning Light



The Traction Control (TC) disabled warning light should not illuminate unless traction control is switched off, or there is a malfunction.

If the warning light becomes illuminated while riding, it indicates that the traction control system has a malfunction that requires investigation. The fault must be checked and rectified by a competent person with the specialist knowledge and technical understanding of motorcycles, such as an authorized Triumph dealer.

Turn signal Light



When the turn signal switch is turned to the left or right, the turn signal light will flash on and off at the same speed as the turn signals.

Hazard Warning Lights



When the hazard warning lights button is turned on, the turn signal lights will flash on and off at the same speed as the turn signals.

High Beam Indicator Light



When the ignition is switched ON and the high beam is selected, the high beam indicator light will illuminate.

Daytime Running Lights (DRL) Indicator Light (if equipped)



The Daytime Running Lights (DRL) indicator light will only illuminate when the DRL is on.

During daylight hours, the daytime running lights improve the visibility of the motorcycle to other road users. Dipped beam headlights must be used in any other conditions unless the road conditions allow for high beam headlights to be used.

When the dipped beam headlight is on, the DRL indicator light will be off.

The automatic dipped beam/DRL headlights are operated manually using a button on the left hand switch housing.

Neutral Indicator Light



The neutral indicator light indicates when the transmission is in neutral (no gear selected). The indicator light will illuminate when the transmission is in neutral with the ignition switch in the ON position.

Low Fuel Indicator Light



The low fuel indicator light will illuminate when there is an approximate level of fuel remaining in the tank, as specified in the Specifications section.

Tire Pressure Warning Light (if equipped with TPMS)



Stop the motorcycle if the tire pressure warning light illuminates.

Do not ride the motorcycle until the tires have been checked and the tire pressures are at their recommended pressure when cold.

Failure to follow the advice above may lead to loss of motorcycle control, which could result in serious injury or death.



The tire pressure warning light works with the Tire Pressure Monitoring System (TPMS), see page 111.

The warning light will only illuminate when the front or rear tire pressure is below the recommended pressure. It will not illuminate if the tire is over inflated.

When the warning light is illuminated, the Tire Pressure display will show which tire is the deflated tire. It will also show the tire pressure.

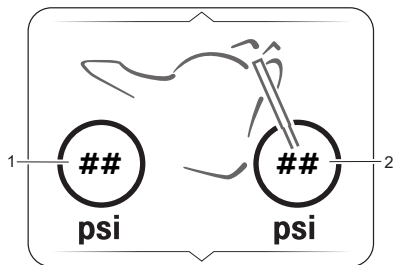

1. Rear tire pressure indicator
2. Front tire pressure indicator

The tire pressure at which the warning light illuminates is temperature compensated to 68°F (20°C), but the numeric pressure display associated with it is not (see page 217). Even if the numeric display seems at or close to the standard tire pressure when the warning light is on, a low tire pressure is indicated and a puncture is the most likely cause.

Low Battery Warning Light

If items such as heated grips are equipped and are on with the engine at idle, over a period of time, the battery voltage may drop below a predetermined voltage and a warning message will be shown.

General Warning Symbol



The general warning symbol will flash if an ABS or engine management fault has occurred and the ABS and/or MIL warning lights are illuminated. The fault must be checked and rectified by a competent person with the specialist knowledge and technical understanding of motorcycles, such as an authorized Triumph dealer.





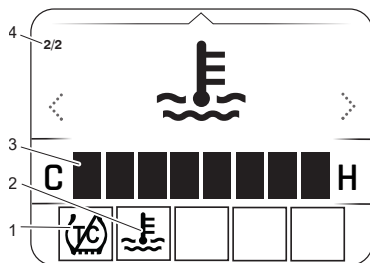

Warning and Information Messages







It is possible for multiple warning and information messages to be shown when a fault occurs. Where this is the case, warning messages will take priority over information messages and the warning symbol(s) will be shown on the display. The number of currently active warning messages is shown in the information tray.



1. Traction control warning symbol (amber indicator)
2. Coolant temperature warning symbol (red indicator)
3. Coolant temperature gage
4. Second of two warnings shown

The following Warning and Information messages may be shown if a fault is detected on the motorcycle.

Warning Lights and Messages	
	Low oil pressure warning light (red indicator)
	Battery low/Starter motor disabled warning light (red indicator)
	Coolant temperature warning light (red indicator)
	Tire Pressure Monitoring System (TPMS) sensor signal - front/rear tire (red or amber indicator)
	Tire Pressure Monitoring System (TPMS) battery low - front/rear tire warning light (red or amber indicator)
	Transmission fault TSA (amber indicator)
	Engine management Malfunction Indicator Light (MIL) (amber indicator)







Warning Lights and Messages	
	Anti-lock Brake System (ABS) or Optimized Cornering Anti-lock Brake System (OCABS) warning light (amber indicator)
	Anti-lock Brake System (ABS) or Optimized Cornering Anti-lock Brake System (OCABS) disabled warning light (amber indicator)
	Bulb failure warning light (amber indicator)
	Traction Control (TC) or Optimized Cornering Traction Control (OCTC) active indicator light (amber indicator)
	Traction Control (TC) or Optimized Cornering Traction Control (OCTC) - system disabled indicator light (amber indicator)
	General warning symbol/Service due/overdue indicator light (amber indicator)
	Immobilizer fault (amber indicator)

INSTRUMENTS

NOTICE

The following indicator lights and messages may be shown during normal operation of the motorcycle.

Information Lights and Messages

	Hazard warning lights (red indicator)
	Low fuel level indicator light (amber indicator)
	Cruise control indicator light (amber or green indicator)
	Turn signal light (green indicator)
	Neutral indicator light (green indicator)
	High beam indicator light (blue indicator)
	Caution: low air temperature - risk of surface ice (blue or white indicator)

To view the warnings:

- ▼ Press the Up/Down button to scroll through the options until the warning message display is shown.
- ▼ Press the Left/Right button to review each warning message (if there is more than one). The warning message counter will show the amount of warning messages that are present.
- ▼ Press the Select button to acknowledge and hide each message.

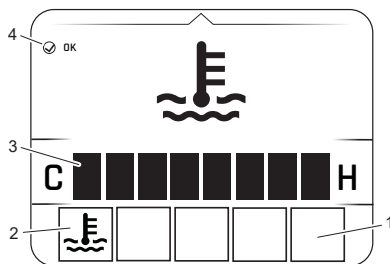

1. Warning symbol(s) display
2. Coolant temperature warning symbol (red indicator)
3. Coolant temperature gage
4. Press select button symbol

Speedometer

The speedometer indicates the road speed of the motorcycle.

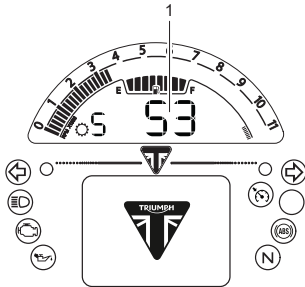

1. Speedometer

Odometer

The odometer shows the total distance that the motorcycle has traveled. The odometer is shown in the Service Interval display, see page 78.



1. Odometer

Tachometer

NOTICE

Never allow engine speed to exceed the maximum engine speed as severe engine damage may result.

The tachometer shows the engine speed in revolutions per minute - rpm (r/min).

Engine speeds above the maximum engine speed are above the range for best engine performance and may result in engine damage.

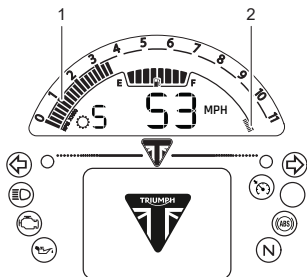

1. Engine speed (rpm)
2. Maximum engine speed

Fuel Gauge

The fuel gage indicates the amount of fuel in the tank.

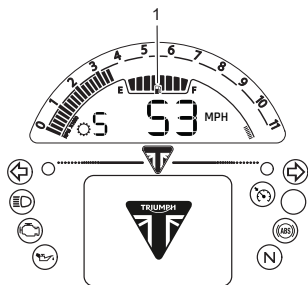

1. Fuel gage

With the ignition switched on, a filled line indicates the fuel remaining in the fuel tank.

The gage markings indicate intermediate fuel levels between E (Empty) and F (Full). The low fuel indicator light will illuminate when there is an approximate level of fuel remaining in the tank, as specified in the Specifications section, and you should refuel at the earliest opportunity.

The range to empty and instantaneous fuel consumption are shown in the Fuel Status display, see page 76.

NOTICE

After refueling, the fuel gage and range to empty information will be updated only while riding the motorcycle. Depending on the riding style, updating could take up to five minutes.

Coolant Temperature Gauge

NOTICE

Stop the engine immediately if a high coolant temperature warning message is shown in the instrument tray.

Do not restart the engine until the fault has been rectified.

Severe engine damage will result from running the engine when a high coolant temperature warning message is shown.

The coolant temperature gage indicates the temperature of the engine coolant.

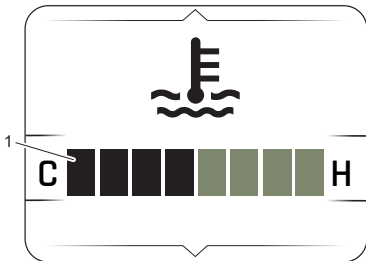

1. Coolant temperature gage

When the engine is started from cold, the display will show gray bars. As the temperature increases, more bars in the display will be shown illuminated. When the engine is started from hot, the display will show the relevant number of illuminated bars, dependent on engine temperature.

The normal temperature range is between the C (Cold) and H (Hot) on the display.

With the engine running, if the engine coolant temperature becomes dangerously high, a warning message will be shown in the instrument tray. The coolant temperature gage is also shown.

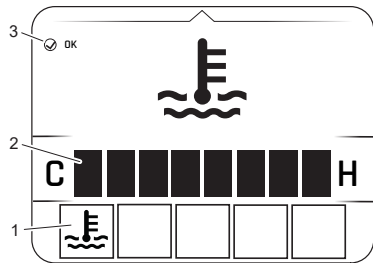

1. Coolant temperature warning symbol (red indicator)
2. Coolant temperature gage
3. Press select button symbol

- ▼ Stop the engine immediately if a high coolant temperature warning message is shown in the instrument tray.
- ▼ Allow the engine temperature to cool for at least 30 minutes.
- ▼ Check and adjust the coolant level as necessary (see page 182 and page 183).

Ambient Air Temperature

Trident 660, Trident 660 - Triple Tribute,
Trident 800, Tiger Sport 660,
Tiger Sport 800 and
Tiger Sport 800 Tour Only

The ambient air temperature is displayed as either °C or °F.

When the motorcycle is stationary, the heat of the engine may affect the accuracy of the ambient temperature display.

Once the motorcycle starts moving, the display will return to normal after a short time.

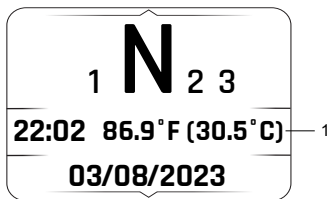

1. Ambient air temperature

To change the temperature from °C or °F, see page 89.

Frost Symbol

WARNING

Black ice (sometimes called clear ice) can form at temperatures several degrees above freezing, 32°F (0°C), especially on bridges and in shaded areas.

Always take extra care when the temperatures are low and reduce speed in potentially hazardous driving conditions, such as bad weather.

Excess speed, hard acceleration, heavy braking or hard cornering when roads are slippery may lead to loss of motorcycle control, which could result in serious injury or death.



The frost symbol will illuminate if the ambient air temperature is 4°C (39°F) or lower.

The frost symbol will remain illuminated until the temperature rises to 6°C (42°F). A message will also be shown in the information tray.

Gear Position

The gear position is shown on the main instrument screen and indicates which gear (one to six) has been engaged. When the transmission is in neutral (no gear selected), N is shown.

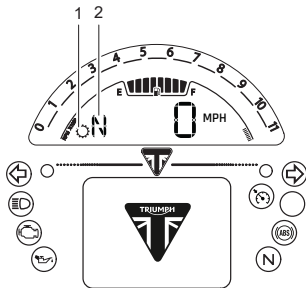

1. Gear position symbol
2. Gear position (neutral position shown)

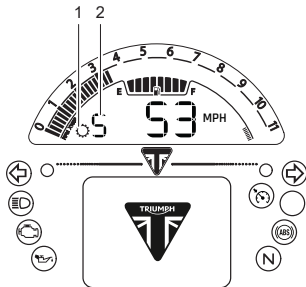

1. Gear position symbol
2. Gear position (fifth gear shown)

The gear position information is not shown when the gear shift indicator display is shown in the information tray.

For more information on the Shift Indicator display, see page 88.

Display Navigation

The table below describes the instrument icons and buttons used to navigate through the instrument menus described in this handbook.

	Mode button.
	Navigation buttons.
	Select button.
	Information Tray - left/right scroll using the navigation buttons.
	Information Tray - up/down scroll using the navigation buttons.
	Information Tray - confirm using the Select button.

Riding Modes

The riding modes allow adjustment of the throttle response (MAP) and Traction Control (TC) settings to suit differing road conditions and rider preferences.

Riding modes can be selected using the Mode button located on the left hand switch housing, while the motorcycle is stationary or moving, see page 74.

The following riding modes are available:

- ▼ Rain
- ▼ Road
- ▼ Sport.

Each riding mode is adjustable, see page 82 for more information.

Rain Mode

The Rain mode provides optimal ABS, MAP and TC settings for normal road use in rain conditions.

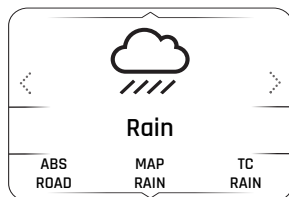

System Settings	
ABS	Road - Optimal ABS setting for road use.
MAP	Rain - Reduced throttle response when compared to the Road setting, for wet or slippery conditions.
TC	Rain - Optimal TC setting for road use in rain conditions, allows minimal rear wheel slip.

Road Mode

The Road mode provides optimal ABS, MAP and TC settings for normal road use.

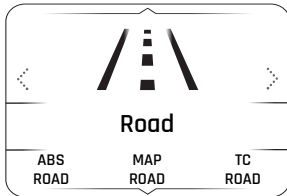

System Settings	
ABS	Road - Optimal ABS setting for road use.
MAP	Road - Standard throttle response.
TC	Road - Optimal TC setting for road use.

Sport Mode

The Sport mode provides optimal ABS, MAP and TC settings for normal sport use.

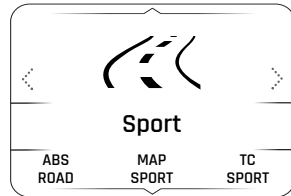

System Settings	
ABS	Road - Optimal ABS setting for road use.
MAP	Sport - Increased throttle response when compared to the Road setting.
TC	Sport - Allows increased rear wheel slip when compared with the Road setting.

Riding Mode Selection

⚠ WARNING

The selection of riding modes while the motorcycle is in motion requires the rider to allow the motorcycle to coast (motorcycle moving, engine running, throttle closed, clutch lever pulled in and no brakes applied) for a brief period of time.

Riding mode selection while the motorcycle is in motion should only be attempted:

- At low speed
- In traffic-free areas
- On straight and level roads or surfaces
- In good road and weather conditions
- Where it is safe to allow the motorcycle to briefly coast.

Riding mode selection while the motorcycle is in motion **MUST NOT** be attempted:

- At high speeds
- While riding in traffic
- During cornering or on winding roads or surfaces
- On steeply inclined roads or surfaces
- In poor road and weather conditions
- Where it is unsafe to allow the motorcycle to coast.

Failure to follow the advice above may lead to loss of motorcycle control, which could result in serious injury or death.

⚠ WARNING

After selecting a riding mode, operate the motorcycle in an area free from traffic to gain familiarity with the new settings.

Do not loan your motorcycle to anyone as they may change the riding mode settings from the one you are familiar with.

Failure to follow the advice above may lead to loss of motorcycle control, which could result in serious injury or death.

NOTICE

The last selected riding mode will be remembered and activated when the ignition is switched ON.

If the riding mode icons are not shown when the ignition switch is in the ON position, make sure that the engine stop switch is in the RUN position.

To select a riding mode:

- ▼ Press and release the Mode button on the left hand switch housing to activate the riding mode selection display.
- ▼ The currently active riding mode icon is shown in the information tray.

To change the selected riding mode:

- ▼ Press the Mode button repeatedly until the required riding mode is shown in the information tray. Once in the riding mode display, the Left or Right buttons will also scroll through the riding mode options.
- ▼ Press the Select button to confirm the selection of the required riding mode.
- ▼ The selected riding mode is activated once the following conditions for switching riding modes have been met:

Motorcycle Stationary - Engine Off

- ▼ The ignition is switched ON.
- ▼ The engine stop switch is in the RUN position.

Motorcycle Stationary - Engine Running

- ▼ Neutral gear is selected or the clutch is pulled in.

Motorcycle in Motion

Within 60 seconds of selecting a riding mode the rider must carry out the following simultaneously:

- ▼ Close the throttle.
- ▼ Make sure that the brakes are not engaged (allow the motorcycle to coast).

The riding mode selection is now complete and normal riding can be resumed.

Information Tray

WARNING

When the motorcycle is in motion, only attempt to switch between the information tray modes or reset the fuel information under the following conditions:

- At low speed
- In traffic-free areas
- On straight and level roads or surfaces
- In good road and weather conditions.

Failure to follow the advice above may lead to loss of motorcycle control, which could result in serious injury or death.

To view the different information tray items, press the Up/Down button until the required information tray item is shown.

The information tray contains the following items:

- ▼ Main Menu, see page 80
- ▼ Trip Meter, see page 76
- ▼ Fuel Status, see page 76
- ▼ Coolant, see page 77
- ▼ Service Interval, see page 78
- ▼ Brightness, see page 78
- ▼ Gear, see page 79

INSTRUMENTS

- ▼ Tachometer, see page 79
- ▼ Warning Information
- ▼ Tire Pressure Monitoring System (TPMS) (if equipped), see page 77
- ▼ Warning and Information Messages, see page 64.

Different information tray items can be shown or hidden from the information tray. For further information, refer to page 88.

Trip Meters

There are two trip meters that can be accessed and reset in the information tray.

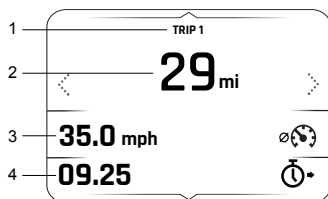

1. Trip meter 1 or 2
2. Duration of trip
3. Average speed
4. Time taken to complete trip

To view and clear a specific trip meter:

- ▼ Press the Left/Right button until the required trip meter is shown.
- ▼ Press and hold the Select button to manually reset the selected trip meter.

For more information on trip meters, see page 85.

Fuel Status

The Fuel Status display shows fuel consumption information.

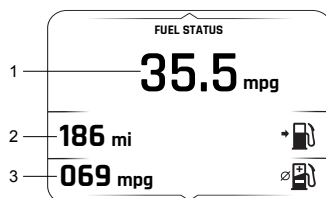

1. Instantaneous fuel consumption
2. Range to empty
3. Average fuel consumption

Instantaneous Fuel Consumption

An indication of the fuel consumption at an instant in time. If the motorcycle is stationary, '-.-' will be shown.

Range to Empty

This is an indication of the predicted distance that can be traveled on the remaining fuel in the tank.

Average Fuel Consumption

This is an indication of the average fuel consumption. After being reset, '0.0' will be shown until 0.1 miles/km has been covered.

NOTICE

After refueling, the fuel gage and range to empty information will be updated only while riding the motorcycle. Depending on the riding style, updating could take up to five minutes.

Tire Pressure Monitoring System (TPMS) (if equipped)

⚠ WARNING

Stop the motorcycle if the tire pressure warning light illuminates.

Do not ride the motorcycle until the tires have been checked and the tire pressures are at their recommended pressure when cold.

Failure to follow the advice above may lead to loss of motorcycle control, which could result in serious injury or death.

The Tire Pressure Monitoring System (TPMS) display shows the front and rear tire pressures.

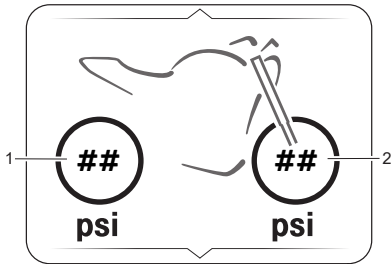

1. Rear tire pressure indicator
2. Front tire pressure indicator

The tire pressure indicators show the current tire pressure.

For the correct tire pressures, refer to the Tires table in the Specifications section (see page 267).

For more information on TPMS, see page 217.

Coolant

The Coolant display shows the temperature of the engine coolant.

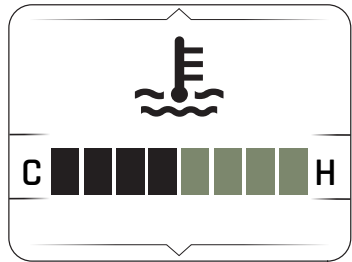

Service Interval

The Service Interval display shows the total distance that the motorcycle has remaining before a service is required. It also shows the date that the service is required to be completed by.

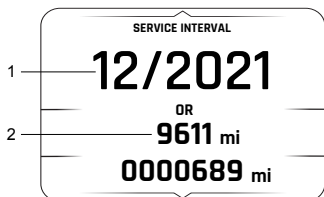

1. Date the service is required by
2. Remaining number of miles or kilometers

If the service is overdue a message is shown in the instrument tray and will remain on until the service has been carried out and the system has been reset.

We recommend the service interval is reset by a competent person with the specialist knowledge and technical understanding of motorcycles, such as an authorized Triumph dealer.

The distance to the next service or any service message will also be shown in the instrument tray when the ignition is turned on.

Brightness

The Brightness display allows the brightness of the information tray to be adjusted.

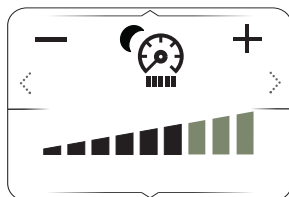

To adjust the brightness of the information tray:

- ▼ Press the Left/Right button to increase/decrease the level of brightness.

In bright sunlight, low brightness settings will be overridden to make sure that the instruments can be viewed at all times.

Do not cover the ambient light sensor on the display screen as this will stop the screen brightness from working correctly.

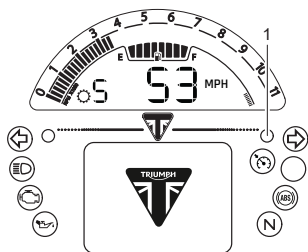

1. Ambient light sensor

Gear

The Gear display shows which gear has been engaged.

Trident 660, Trident 660 - Triple Tribute,
Trident 800, Tiger Sport 660,
Tiger Sport 800 and
Tiger Sport 800 Tour

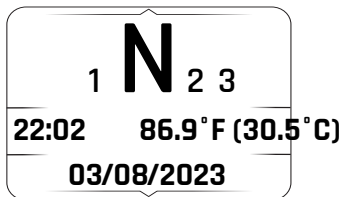

Daytona 660

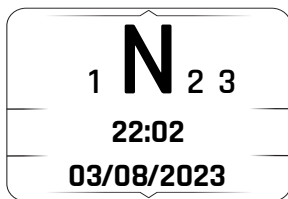

The time, date and ambient air temperature is only shown in the gear display.

For more information on how to set the time and date, see page 90 and page 91.

Tachometer

The Tachometer display shows the current engine speed.

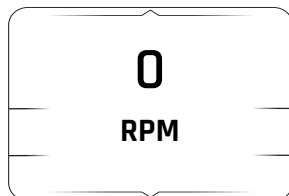

Main Menu



To access the Main Menu:

- ▼ The motorcycle must be stationary with the ignition switched on.
- ▼ Press the Up/Down button to scroll through the information tray until the Main Menu screen is shown.
- ▼ Press the Select button to open the Main Menu.

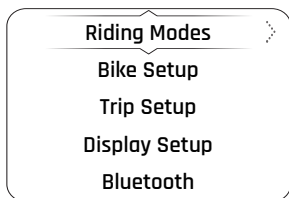

The Main Menu allows access to the following options:

Riding Modes

This menu allows configuration of the riding modes. For more information, see page 81.

Bike Setup

This menu allows configuration of the different features of the motorcycle. For more information, see page 83.

Trip Setup

This menu allows configuration of Trip 1 and Trip 2. For more information, see page 85.

Display Setup

This menu allows configuration of the display options. For more information, see page 87.

page 225® (if equipped)

This menu allows configuration of the Bluetooth® connectivity. For more information, see page 92.

Reset To Defaults

This menu allows all instrument settings to be returned to the default setting. For more information, see page 92.

Riding Modes

To access the Riding Modes menu:

- ▼ From the Main Menu, press the Up/Down button to select Riding Modes.
- ▼ Press the Right button to view the available options.

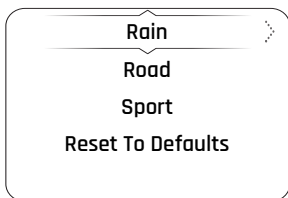

- ▼ Press the Up/Down button to select the required riding mode.
- ▼ Press the Right button to view the relevant setting options for the selected riding mode.

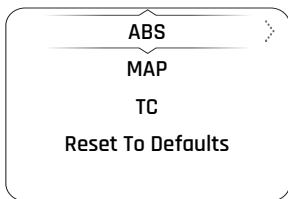



To change the MAP or Traction Control (TC) settings:

NOTICE

The ABS is set to Standard (factory default settings) for all riding modes and cannot be changed.

- ▼ Press the Up/Down button to select the setting.
- ▼ Press the Right button to view the available options.
- ▼ Press the Up/Down button to scroll through the options.
- ▼ Press the Select button to select the required option for the specific setting. A tick is shown to indicate the selected option.

Riding Mode Configuration

Riding Mode Configuration Options			
	RAIN 	ROAD 	SPORT 
Anti-lock Braking System (ABS)			
Road	●	●	●
MAP (Throttle Response)			
Rain	●	○	∅
Road	○	●	○
Sport	∅	○	●
Traction Control (TC)			
Rain	●	○	∅
Road	○	●	○
Sport	∅	○	●
Key			
●	Standard (factory default setting)		
○	Selectable option		
∅	Option not available		

Bike Setup Menu

The Bike Setup menu allows configuration of the different features of the motorcycle.

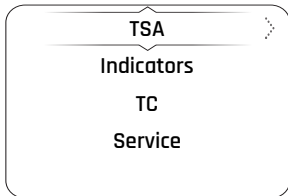

To access the Bike Setup menu:

- ▼ From the Main Menu, press the Up/Down button to select Bike Setup.
- ▼ Press the Right button to view the available options.

Bike Setup - TSA (if equipped)

Triumph Shift Assist (TSA) triggers a momentary engine torque change to allow gears to engage, without closure of the throttle or operation of the clutch. This feature works for both up-shifts and down-shifts of gear.

The clutch must be used for stopping and pulling away.

TSA will not operate if the clutch is applied or if an up-shift is attempted by mistake when in 6th gear.

It is necessary to use a positive pedal force to make sure there is a smooth gear shift.

To enable or disable TSA:

- ▼ From the Bike Setup menu, press the Up/Down button to select TSA.
- ▼ Press the Right button to view the available options.

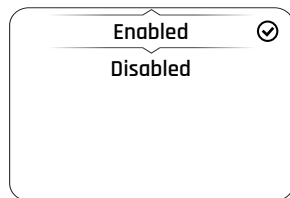

- ▼ Press the Up/Down button to select Enabled or Disabled.
- ▼ Press the Select button to confirm. A tick is shown to indicate the selected option.

For more information on Triumph Shift Assist (TSA), see page 150.

INSTRUMENTS

Bike Setup - Indicators

The turn signals can be set to Automatic or Manual mode.

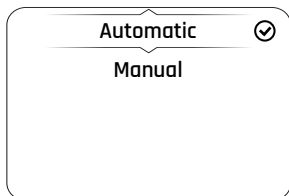

Selecting a Turn Signals Mode

To select the required turn signals mode:

- ▼ From the Bike Setup menu, press the Up/Down button to select Indicators.
- ▼ Press the Right button to view the available options.
- ▼ Press the Up/Down button to scroll between the following options:
 - Automatic- The self-canceling function is on. The turn signals will activate for eight seconds and an additional 71 yards (65 meters).
 - Manual - The self-canceling function is off. The turn signals must be manually canceled using the turn signal switch.
- ▼ Press the Select button to confirm. A tick is shown to indicate the selected option.

Bike Setup - Traction Control (TC)

The Traction Control (TC) system can be temporarily disabled. The Traction Control (TC) system cannot be permanently disabled, it will be automatically enabled when the ignition is turned off and then on again.

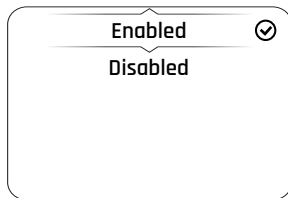

To enable or disable the TC system:

- ▼ From the Bike Setup menu, press the Up/Down button to select TC.
- ▼ Press the Right button to view the available options.
- ▼ Press the Up/Down button to select Enabled or Disabled.
- ▼ Press the Select button to confirm. A tick is shown to indicate the selected option.

Bike Setup - Service

The service interval is set to a distance and/or time period.

To review the service interval:

- ▼ From the Bike Setup menu, press the Up/Down button to select Service.
- ▼ Press the Right button to view the Service information.

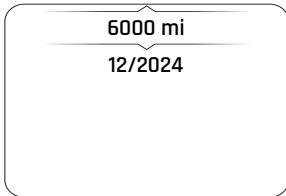

Trip Setup Menu

The Trip Setup menu allows the configuration of the trip meters.

To access the Trip Setup menu:

- ▼ From the Main Menu, press the Up/Down button to select Trip Setup.
- ▼ Press the Right button to view the available options.

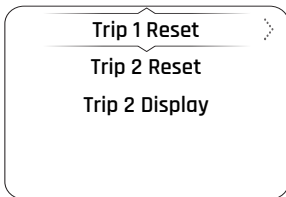

Selecting Trip 1 Reset or Trip 2 Reset allows the relevant trip meter to be configured manually or automatically. The trip meter set up procedure is the same for both trip meters.

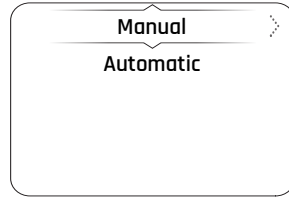

Manual reset will only reset the selected trip meter when the rider manually chooses to reset it. For more information, see page 86.

Automatic reset will reset each trip meter after the ignition has been switched off for a set time. For more information, see page 86.

Trip meter 2 can be enabled or disabled. For more information, see page 87.

INSTRUMENTS

Trip Setup - Manual Reset

To set the trip meter to reset manually:

- ▼ From the Trip Setup menu, press the Up/Down button to select Trip 1 Reset or Trip 2 Reset.
- ▼ Press the Right button to view the available options.
- ▼ Press the Up/Down button to select Manual.
- ▼ Press the Right button to view the available options.
- ▼ Select the required option and press the Select button to confirm.

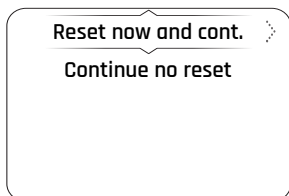

There are two options:

- ▼ Reset now and cont. - Resets all trip meter data in the relevant trip meter.
- ▼ Continue no reset - Any trip meter data in the relevant trip meter will not be reset.

Trip Setup - Automatic Reset

To set the trip meter to reset automatically:

- ▼ From the Trip Setup menu, press the Up/Down button to select Trip 1 Reset or Trip 2 Reset.
- ▼ Press the Right button to view the available options.

- ▼ Press the Up/Down button to select Automatic.
- ▼ Press the Right button to view the available options.
- ▼ Press the Up/Down button to select the timer setting required.
- ▼ Press the Select button to confirm. A tick is shown to indicate the selected option.
- ▼ The required time limit is then stored in the trip memory.
- ▼ When the ignition is turned off, the trip meter is set to zero when the time period has elapsed.

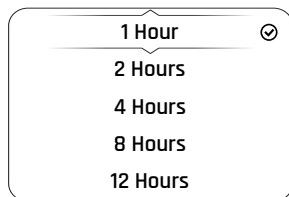

The following table shows two examples of the automatic trip reset functionality.

Ignition Turned Off	Selected Time Delay	Trip Meter Resets to Zero
10:30 hrs	4 Hours	14:30 hrs
18:00 hrs	16 Hours	10:00 hrs (next day)

Trip 2 Display

The Trip 2 Display menu allows the Trip 2 meter to be enabled or disabled. If Trip 2 is disabled, it will no longer be shown in the information tray.

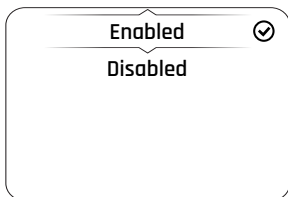

To enable or disable the Trip 2 meter:

- ▼ From the Trip Setup menu, press the Up/Down button to select Trip 2 Display.
- ▼ Press the Right button to view the available options.
- ▼ Press the Up/Down button to select Enabled or Disabled.
- ▼ Press the Select button to confirm. A tick is shown to indicate the selected option.

Display Setup Menu

The Display Setup menu allows configuration of the different display screen options.



To access the Display Setup menu:

- ▼ From the Main Menu, press the Up/Down button to select Display Setup.
- ▼ Press the Right button to view the available options.
- ▼ Select the required option from the list to access the relevant information.

Display Setup - Brightness

There are eight levels of brightness options to select from. Level 7 is the brightest option.

To adjust the brightness:

- ▼ From the Display Setup menu, press the Up/Down button to select Brightness.
- ▼ Press the Right button to view the available options.
- ▼ Press the Up/Down button until the required brightness option is highlighted.
- ▼ Press the Select button to confirm. A tick is shown to indicate the selected option.

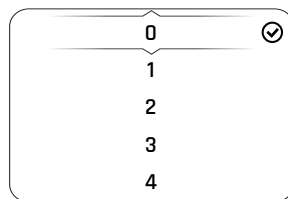

NOTICE

In bright sunlight, low brightness settings will be overridden to make sure that the instruments can be viewed at all times.

INSTRUMENTS

Display Setup - Visible Trays

The Visible Trays menu allows the selection of the items to be shown in the information tray.

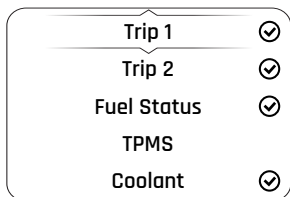

To select the Visible Trays menu:

- ▼ From the Display Setup menu, press the Up/Down button to select Visible Trays.
- ▼ Press the Right button to view the available options.
- ▼ Press the Up/Down button until the required information tray item is highlighted.
- ▼ Press the Select button to select/deselect the information tray.
- ▼ An information tray item with a tick next to it will be shown in the information tray. An information tray item without a tick next to it will not be shown in the information tray.

Display Setup - Shift Indicator

The Shift Indicator menu allows the adjustment of the gear shift indicator.

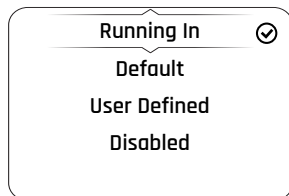

The engine speed threshold can be defined and reset, and the gear shift indicator can be disabled. Once the engine has been broken in (at 1,000 miles/1,600 km), the Running In option is replaced with a Default option.

To adjust the engine speed threshold (RPM) for the gear shift indicator:

- ▼ From the Shift Indicator menu, press the Up/Down button to select User Defined and press the Select button to confirm.

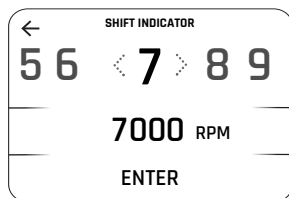

NOTICE

The previously stored or default rpm will be shown initially.

- ▼ Press the Down button to highlight the numbers.
- ▼ Press the Left/Right button to scroll through to the delete symbol.
- ▼ Press the Select button to delete each number.

- ▼ Press the Left/Right button to scroll through the numbers.
- ▼ Press the Select button to confirm the number. Numbers other than '0' will add in hundreds, for example, '4' will add '400' each time it is selected.
- ▼ Once the engine speed threshold (RPM) has been completed, select ENTER and press the Select button to confirm. This will revert back to the previous screen.

To disable the gear shift indicator:

- ▼ Press the Up/Down button to select Disabled and press the Select button to confirm.

Display Setup - Language

The Language menu allows the preferred language to be used as the instrument display language.



To select the required language for the instrument display:

- ▼ From the Display Setup menu, press the Up/Down button to select Language.
- ▼ Press the Right button to view the available options.
- ▼ Press the Up/Down button until the required language option is highlighted.
- ▼ Press the Select button to confirm. A tick is shown to indicate the selected option.

Display Setup - Units

The Units menu allows the selection of a preferred unit of measurement.

Trident 660, Trident 660 - Triple Tribute, Trident 800, Tiger Sport 660, Tiger Sport 800 and Tiger Sport 800 Tour

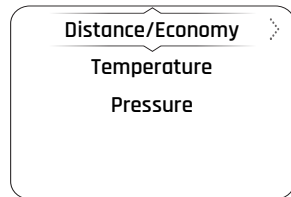

Daytona 660

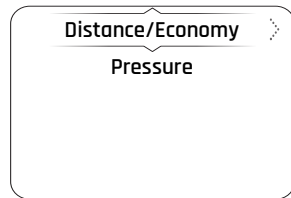

All Models

To select the required units of measurement:

- ▼ From the Display Setup menu, press the Up/Down button to select Units.
- ▼ Press the Right button to view the available options.

To change the unit of measurement:

- ▼ Press the Up/Down button to select the required option.
- ▼ Press the Right button to view the available options.
- ▼ Press the Up/Down button until the required unit of measurement is highlighted.

INSTRUMENTS

- ▼ Press the Select button to confirm. A tick is shown to indicate the selected option.

The options available are:

Distance/Economy: Miles & MPG (UK), Miles & MPG (US), Km & L/100km, Km & Km/L.

Temperature (if equipped): °C, °F.

Pressure: PSI, Bar, kPa.

Display Setup - Clock

The Clock menu allows the adjustment of the clock to be set to the local time.

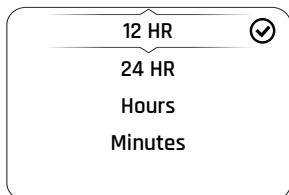

To set the clock:

- ▼ From the Display Setup menu, press the Up/Down button to select Clock.
- ▼ Press the Right button to view the available options.
- ▼ Press the Up/Down button to select 12 HR or 24 HR clock and press the Select button to confirm. A tick is shown to indicate the selected option.
- ▼ The clock will display in either 12 or 24 hour format depending on selection.

To adjust the hour setting:

- ▼ Select Hours and press the Right button to be shown the HOURS display.

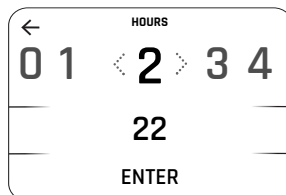

- ▼ Press the Down button to highlight the numbers.
- ▼ Press the Left/Right button to scroll through to the delete symbol.
- ▼ Press the Select button to delete each number.
- ▼ Press the Left/Right button to scroll through the numbers to select the correct time in hours. Once the required number is highlighted, press the Select button to confirm. The number appears below. Repeat this step to select the next number.
- ▼ When the hour number is correct, select ENTER and press the Select button to confirm. This will revert back to the previous screen.

To adjust the minute setting:

Repeat the procedure used to set the hour by selecting Minutes.

Display Setup - Date

The Date menu allows the date and date format to be adjusted.

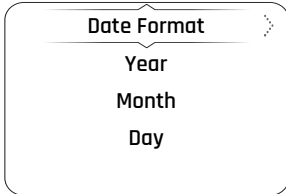

To set the date format:

- ▼ From the Display Setup menu, press the Up/Down button to select Date.
- ▼ Press the Right button to view the available options.
- ▼ Press the Up/Down button to select Date Format.
- ▼ Press the Right button to view the available options.

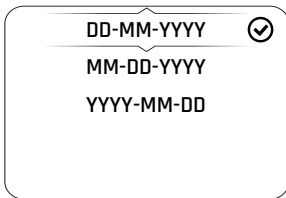

- ▼ Press the Up/Down button to select the required date format option and press the Select button to confirm. A tick is shown to indicate the selected option.

To set the year:

- ▼ From the Display Setup menu, press the Up/Down button to select Date.
- ▼ Press the Right button to view the available options.
- ▼ Press the Up/Down button to select Year.
- ▼ Press the Right button to show the SET YEAR display.

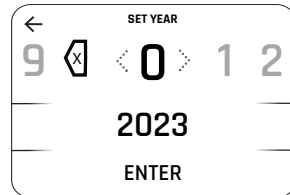

- ▼ Press the Down button to highlight the numbers.
- ▼ Press the Left/Right button to scroll through to the delete symbol.
- ▼ Press the Select button to delete each number.
- ▼ Press the Left/Right button to scroll through the numbers to select the required first number of the four digit year. Once the required number is highlighted, press the Select button to confirm. The number appears below. Repeat the procedure until the year required is shown.
- ▼ When the year is correct, select ENTER and press the Select button to confirm. This will revert back to the previous screen.

INSTRUMENTS

To set the month:

- ▼ From the Display Setup menu, press the Up/Down button to select Date.
- ▼ Press the Right button to view the available options.
- ▼ Press the Up/Down button to select Month.
- ▼ Press the Right button to show the SET MONTH display.

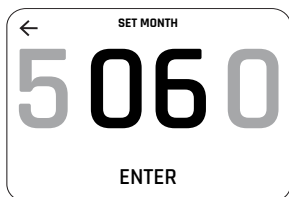

- ▼ Press the Down button to highlight the numbers.
- ▼ Press the Left/Right button to scroll through the numbers to select the required month.
- ▼ When the month is correct, select ENTER and press the Select button to confirm. This will revert back to the previous screen.

To set the day:

Repeat the procedure used to set the month by selecting Day.

Reset to Defaults

The Reset to Defaults option allows the Main Menu display items to be reset to the default setting.

To reset the Main Menu display items:

- ▼ From the Main Menu, press the Up/Down button to select Reset To Defaults.
- ▼ Press the Up/Down button to select Confirm or Cancel. Press the Select button to confirm.

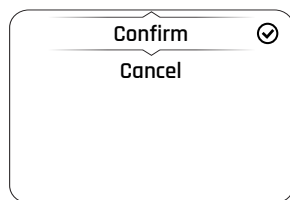

- ▼ Confirm - All main menu settings and data will be reset to the factory default values including Riding Modes, Trip Meters, Visible Trays, Language, Traction Control and Display Brightness.
- ▼ Cancel - The main menu settings and data will remain unchanged and the display will return to the previous menu level.

Bluetooth®

For information on Bluetooth® features, see the My Triumph Connectivity Handbook at www.triumphtechnicalinformation.com/handbooks.

Table of Contents

Controls	95
Throttle Control.....	95
Ignition Switch/Steering Lock	96
Ignition Key	96
Engine Immobilizer	98
Brake Lever Adjuster.....	98
Clutch Lever	98
Right Handlebar Switches.....	99
Left Handlebar Switches.....	100
Heated Grips Button (if equipped).....	103
Fuel.....	104
Refueling	106
Fuel Tank Cap.....	106
Filling the Fuel Tank.....	107
Cruise Control (if equipped).....	107
Activating Cruise Control.....	108
Deactivating Cruise Control.....	108
Traction Control (TC).....	109
Optimized Cornering Traction Control (OCTC) (if equipped).....	109
Traction Control Settings.....	110
Tire Pressure Monitoring System (TPMS) (if equipped).....	111
Tire Pressures.....	111
Tire Pressure Sensor Batteries	112
Tire Pressure Sensor Serial Number	113
Replacement Tires.....	113

GENERAL INFORMATION

Stands	113
Side Stand	113
Center Stand (if equipped).....	114
Paddock Stand Pegs	115
Seats	115
Seat Care.....	115
Seat Lock	115
Seat - Removal.....	116
Seat - Installation.....	117
Fairings	120
Fairings - Removal	120
Fairings - Installation.....	123
Luggage Systems	126
Panniers - Operation	126
Panniers - Removal	128
Panniers - Installation.....	129
Twin Helmet Top Box - Operation.....	130
Twin Helmet Top Box - Removal.....	132
Twin Helmet Top Box - Installation	137
Twin Helmet Top Box - Release Mechanism Lubrication	139
Windshield (if equipped)	140
Owner's Handbook and Tool Kit	141
Breaking-In	142
Daily Safety Checks	143

Controls

Throttle Control

An electronic throttle twist grip controls the opening and closing of the throttles via the engine's electronic control module. There are no direct-acting cables in the system.

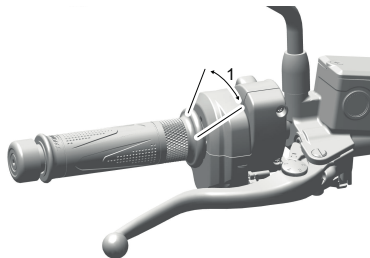

1. Throttle closed position (Trident 660 shown)

The throttle grip has a resistive feel to it as it is rolled rearwards to open the throttles. When the grip is released, it will return to the throttle closed position by its internal return spring and the throttles will close.

There are no user adjustments for the throttle control.

If there is a malfunction with the throttle control, the Malfunction Indicator Light (MIL) becomes illuminated and one of the following engine conditions may occur:

- ▼ MIL illuminated, restricted engine RPM and throttle movement.
- ▼ MIL illuminated, limp-home mode with the engine at a fast idle condition only.
- ▼ MIL illuminated, engine will not start.

For all of the conditions mentioned, the fault must be checked and rectified by a competent person with the specialist knowledge and technical understanding of motorcycles, such as an authorized Triumph dealer.

! WARNING

Reduce speed and do not continue to ride for longer than is necessary with the Malfunction Indicator Light (MIL) illuminated. The fault may affect engine performance, exhaust emissions and fuel consumption.

The fault must be checked and rectified by a competent person with the specialist knowledge and technical understanding of motorcycles, such as an authorized Triumph dealer.

Reduced engine performance could cause a dangerous riding condition, leading to loss of motorcycle control which could result in serious injury or death.

Brake Use

At low throttle opening (approximately 20°), the brakes and throttle can be used together.

At high throttle opening (greater than 20°), if the brakes are applied for more than two seconds the throttles will close and the engine speed will reduce. To return to normal throttle operation, release the throttle control, release the brakes and then reopen the throttle.

GENERAL INFORMATION

Ignition Switch/Steering Lock

⚠ WARNING

For reasons of security and safety, always turn the ignition to the OFF or PARK (if equipped) position and remove the key when leaving the motorcycle unattended.

Any unauthorized use of the motorcycle may lead to loss of motorcycle control which could result in serious injury or death.

⚠ WARNING

With the key in the LOCK or PARK (if equipped) position, the steering will become locked.

Never turn the key to the LOCK or PARK (if equipped) positions while the motorcycle is moving as this will cause the steering to lock.

Locked steering will lead to loss of motorcycle control which could result in serious injury or death.

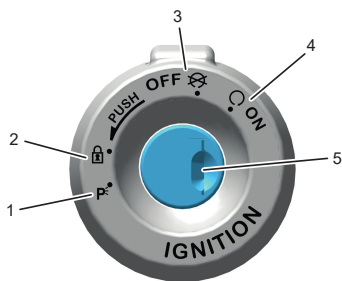

1. PARK position
2. LOCK position
3. OFF position
4. ON position
5. Ignition switch/steering lock

Switch Operation

This is a four position, key operated switch. The key can be removed from the switch only when it is in the OFF, LOCK or P (PARK) position.

TO LOCK: Turn the steering fully to the left, turn the key to the OFF position, push and fully release the key, then rotate it to the LOCK position.

PARKING: Turn the key from the LOCK position to the P (PARK) position. The steering will remain locked.

NOTICE

Do not leave the ignition switch in the P (PARK) position for long periods of time as this will cause the battery to discharge.

Ignition Key

⚠ WARNING

Additional keys, key rings/chains or items attached to the ignition key may interfere with the steering.

Remove all additional keys, key rings/chains and items from the ignition key before riding the motorcycle.

Failure to follow the advice above may lead to loss of motorcycle control, which could result in serious injury or death.

NOTICE

Additional keys, key rings/chains or items attached to the ignition key may cause damage to the motorcycle's painted or polished components.

Remove all additional keys, key rings/chains and items from the ignition key before riding the motorcycle.

NOTICE

Do not store the spare key with the motorcycle as this will reduce all aspects of security.

NOTICE

Key functions may be disrupted by electronic devices, environmental electrical noise sources and metal objects.

Avoid storing and using the key near the following:

- Electrical service masts, radio masts and power distribution infrastructure
- Garage door opener devices
- Radio-Frequency Identification (RFID) access cards or fobs
- Metal, metallic card holders and aluminum items
- Other vehicle electronic keys
- In panniers or top boxes
- Wireless communication devices such as mobile phones, tablets, laptops, portable game systems, audio players, radios and chargers.

In addition to operating the ignition switch/steering lock, the ignition key is required to operate the seat lock and fuel tank cap.

When the motorcycle is delivered from the factory, two ignition keys are supplied together with a small tag bearing the key number. Make a note of the key number and store the spare key and key number tag in a safe place away from the motorcycle.

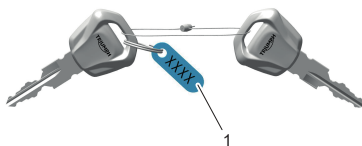
**1. Key number tag**

There is a transponder within the ignition keys to turn off the engine immobilizer. To make sure the immobilizer functions correctly, always have only one of the ignition keys near the ignition switch. Having two ignition keys near the switch may interrupt the signal between the transponder and the engine immobilizer. In this situation, the engine immobilizer will remain active until one of the ignition keys is removed.

Always get replacement keys from your authorized Triumph dealer. Replacement keys must be 'paired' with the motorcycle's immobilizer by your authorized Triumph dealer.

GENERAL INFORMATION

Engine Immobilizer

The ignition barrel housing acts as the antenna for the engine immobilizer. When the ignition switch is turned to the OFF position and the ignition key is removed, the engine immobilizer is active, see page 60. The engine immobilizer is deactivated when the ignition key is in the ignition switch and it is turned to the ON position.

Brake Lever Adjuster

⚠ WARNING

Do not attempt to adjust the levers with the motorcycle in motion as this could lead to loss of motorcycle control.

After adjusting the levers, operate the motorcycle in an area free from traffic to gain familiarity with the new lever setting.

Do not loan your motorcycle to anyone as they may change the lever setting from the one you are familiar with, leading to loss of motorcycle control, which could result in serious injury or death.

A span adjuster is installed to the brake lever. The adjuster allows the distance from the handlebar to the brake lever to be changed to suit the span of the rider's hand.

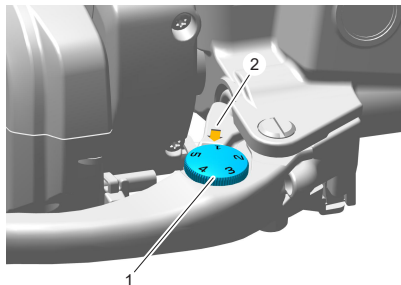

1. Adjuster wheel (Trident 660 shown)
2. Arrow mark

- ▼ Push the brake lever forward and turn the adjuster wheel to align one of the numbered positions with the arrow mark on the lever holder.
- ▼ The distance from the handlebar grip to the released brake lever is shortest when set to number five and longest when set to number one.

Clutch Lever

The clutch lever has a fixed span. It is not adjustable.

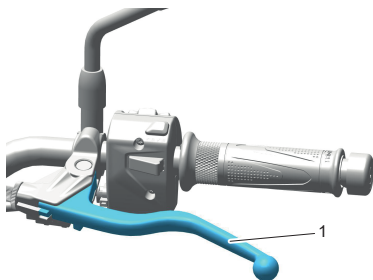

1. Clutch lever (Trident 660 shown)

Right Handlebar Switches

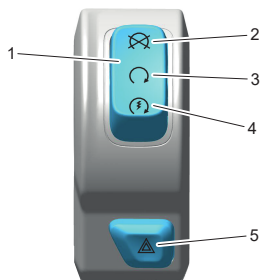

1. Engine start/stop switch
2. STOP position
3. RUN position
4. START position
5. Hazard warning lights button

STOP Position

NOTICE

Although the STOP position on the engine start/stop switch stops the engine, it does not turn off all the electrical circuits and may cause difficulty in restarting the engine due to a discharged battery. Ordinarily, only the ignition switch should be used to stop the engine.

Do not leave the ignition switch in the ON position unless the engine is running as this may cause damage to electrical components and will discharge the battery.

The STOP position is for emergency use. If an emergency arises which requires the engine to be stopped, move the engine start/stop switch to the STOP position.

RUN Position

In addition to the ignition switch being turned to the ON position, the engine start/stop switch must be in the RUN position for the motorcycle to operate.

START Position

NOTICE

Even if the clutch lever is pulled to the handlebar, the starter will not operate if the side stand is down and a gear is engaged.

The START position operates the electric starter. For the starter to operate, the clutch lever must be pulled to the handlebar.

Hazard Warning Lights Button

To turn the hazard warning lights on or off, press and release the hazard warning lights button.

The ignition must be switched ON for the hazard warnings lights to function.

The hazard warning lights will remain on if the ignition is switched OFF, until the hazard warning lights button is pressed again.

GENERAL INFORMATION

Left Handlebar Switches

Without Cruise Control, Without DRL

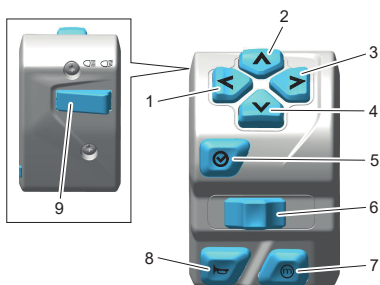

1. Left button
2. Up button
3. Right button
4. Down button
5. Select button
6. Turn signal switch
7. Mode button
8. Horn button
9. High beam button

With Cruise Control, Without DRL

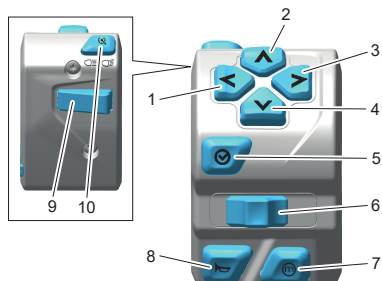

1. Left button
2. Up button
3. Right button
4. Down button
5. Select button
6. Turn signal switch
7. Mode button
8. Horn button
9. High beam button
10. Cruise control button

With Cruise Control, With DRL

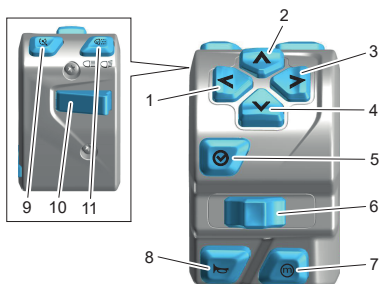

1. Left button
2. Up button
3. Right button
4. Down button
5. Select button
6. Turn signal switch
7. Mode button
8. Horn button
9. Cruise control button
10. High beam button
11. Daytime Running Lights (DRL) button

Navigation Buttons

The navigation buttons are used to operate the following functions of the instruments:

- ▼ Up - scroll the menu bottom to top
- ▼ Down - scroll the menu top to bottom
- ▼ Left - scroll the menu to the left
- ▼ Right - scroll the menu to the right.

Turn Signal Switch

When the turn signal switch is pushed to the left or right, the corresponding turn signals will flash on and off.

The turn signals can be canceled manually. To manually turn off the turn signals, push and release the turn signal switch in the central position.

Automatic self-canceling indicators can be activated in the Bike Set Up function on the display, refer to page 84.

When in automatic self-canceling mode and the motorcycle stops for any reason, the indicators will flash for the remainder of the time and distance unless manually canceled by the rider.

Mode Button

When the Mode button is pressed and released, it will activate the riding mode display. Further presses of the Mode button will scroll through the available riding modes (see page 74).

Horn Button

When the horn button is pressed, with the ignition switch turned on, the horn will sound.

High Beam Button

When the high beam button is pressed, the high beam will be switched on. Each press of the button will swap between dip and high beam.

If daytime running lights are installed on the motorcycle, the high beam button has additional functionality.

If the DRL is on, press and hold the high beam button to turn the high beam on. It will remain on as long as the button is held in and will turn off as soon as the button is released.

The headlight will function when the ignition switch is turned to the ON position. The headlight will go off while pressing the starter button until the engine starts.

GENERAL INFORMATION

A lighting on/off switch is not installed on this model. The position light, brake/tail light and license plate light all function automatically when the ignition is turned to the ON position.

A Pass feature is not available on this model.

Cruise Control Button (if equipped)

When the cruise control button is pressed, the cruise control is on standby (amber indicator). A second press of the button will activate cruise control (green indicator).

To turn off the amber indicator, press and hold the cruise control button for three seconds.

Cruise control can be switched on or off at any time but it cannot be activated until certain conditions have been met. For more information, see page 107.

Automatic Daytime Running Lights (DRL) Button (if equipped)

WARNING

Do not ride for longer than necessary in poor ambient light conditions with the Daytime Running Lights (DRL) in use.

Riding with the DRL when dark, in tunnels or where poor ambient light is apparent may reduce the rider's vision or blind other road users.

Blinding other road users or reduced vision in low ambient light levels may lead to loss of motorcycle control, which could result in serious injury or death.

NOTICE

During daylight hours, the Daytime Running Lights (DRL) improve the visibility of the motorcycle to other road users.

Dipped beam headlights must be used in any other conditions unless the road conditions allow for high beam headlights to be used.

When the ignition is switched ON, the automatic Daytime Running Lights (DRL) feature will be enabled. In this mode, the headlight will automatically switch between DRL and dipped beam depending on the surrounding ambient light brightness.

When the automatic DRL button is pressed, the dipped beam will illuminate.

The DRL indicator light will illuminate in the instrument panel when the DRL are on.

To turn on the automatic DRL, press the button again.

Heated Grips Button (if equipped)

The heated grips will only heat when the engine is running.

When the heated grips are switched on, the heated grips symbol will appear in the display and the selected heat level will be shown.

There are three levels of heat: low, medium and high. This is indicated by the different colors of the symbols shown in the display.

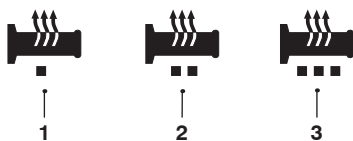

1. Low heat symbol (yellow)
2. Medium heat symbol (orange)
3. High heat symbol (red)

For maximum benefit in cold conditions, from the OFF position press the button once for the high heat setting initially and then reduce the heat level by pressing the button again for a low heat setting when the grips have warmed up.

To turn off the heated grips, press and release the button until the heated grips symbol is no longer shown in the display.

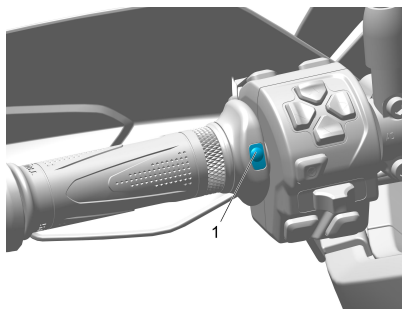

1. Heated grip button

Low Power Voltage Cut Off

If a low voltage is detected, the heated grips will power off. The heated grips will not function again until the voltage rises to a safe level.

The heated grips will not power back on automatically even if the voltage rises to the safe level. The heated grips button must be manually pressed again to activate the heated grips.

GENERAL INFORMATION

Fuel



The fuel grade required for the motorcycle is stated in the relevant Specifications section. Always check that the correct fuel grade is being used before filling the tank.

Triumph motorcycles are designed to use unleaded fuel and will give optimum performance if the correct grade of fuel is used.

Fuel grade is described as either Research Octane Number (RON) or Motor Octane Number (MON), or Cost of Living Council (CLC) or Anti-Knock Index (AKI) octane rating (R+M)/2.

In North America, federal regulations require that pumps delivering unleaded gasoline are marked 'UNLEADED' and that the CLC or AKI octane rating is also displayed. These ratings are an average of the RON and the MON.

Ethanol

In Europe, Triumph motorcycles are compatible with Ethanol E5 and E10 (5% and 10% Ethanol) unleaded fuel.

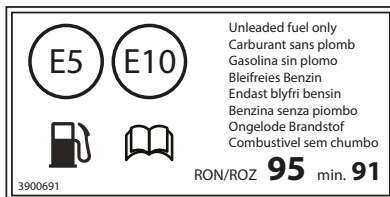

91 RON Fuel Grade Label Shown

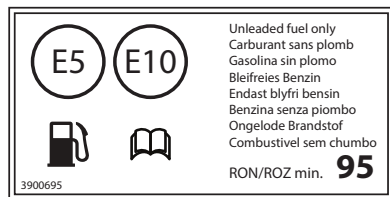

95 RON Fuel Grade Label Shown

In all other markets Ethanol up to E25 (25% Ethanol) may be used.

Engine Calibration

In certain circumstances engine calibration may be required. This should be completed by a competent person with the specialist knowledge and technical understanding of motorcycles, such as an authorized Triumph dealer.

GENERAL INFORMATION

NOTICE

The motorcycle can be permanently damaged if it is allowed to operate with the incorrect grade of fuel or incorrect engine calibration.

Always make sure that the fuel used is of the correct grade and quality.

Damage caused by using the incorrect fuel or engine calibration is not considered a manufacturing defect, and will not be covered under warranty.

NOTICE

In many countries, the exhaust system for this model is equipped with a catalytic converter to help reduce exhaust emission levels.

Use of leaded fuel will damage the catalytic converter. In addition, the catalytic converter can be permanently damaged if the motorcycle is allowed to run out of fuel or if the fuel level is allowed to get very low.

Always make sure you have adequate fuel for your trip.

NOTICE

The use of leaded fuel is illegal in some countries, states or territories.

NOTICE

If detonation ('knocking' or 'pinging') occurs at a steady engine speed under normal load, use a different brand of gasoline or gasoline that has a higher octane rating.

Oxygenated Gasoline

To help in meeting clean air standards, some areas of the U.S. use oxygenated gasoline to help reduce harmful emissions. These gasolines are a blend of conventional gasoline and another compound, such as alcohol. This Triumph motorcycle will give its best performance when using unleaded gasoline. However, the following should be used as a guide if you use any oxygenated fuels.

Ethanol

Ethanol fuel is a mixture of 10% Ethanol and 90% gasoline and is often described under the names 'gasohol', 'Ethanol enhanced', or 'contains Ethanol'. This fuel may be used in your Triumph motorcycle.

MTBE (Methyl Tertiary Butyl Ether)

The use of gasolines containing up to 15% MTBE (Methyl Tertiary Butyl Ether) is permitted in this Triumph motorcycle.

Methanol

Fuels containing methanol should not be used as damage to components in the fuel system can be caused by contact with methanol.

NOTICE

Because of the generally higher volatility of oxygenated fuels, starting, engine response and fuel consumption may be adversely affected by their use. Should any of these difficulties be experienced, run the motorcycle on normal unleaded gasoline.

GENERAL INFORMATION

Refueling

⚠ WARNING

To help reduce hazards associated with refueling, always observe the following fuel safety instructions:

- Gasoline (fuel) is highly flammable and can be explosive under certain conditions. When refueling, turn the ignition switch to the OFF position.
- Do not smoke.
- Do not use a mobile telephone.
- Make sure that the refueling area is well ventilated and free from any source of flame or sparks. This includes any appliance with a pilot light.
- Pay full attention and remain alert while refueling.
- Never fill the tank until the fuel level rises into the filler neck. Heat from sunlight or other sources may cause the fuel to expand and overflow creating a fire hazard.
- After refueling always check that the fuel filler cap is correctly closed.
- Because gasoline (fuel) is highly flammable, any fuel leak or spillage, or any failure to observe the safety advice given above will lead to a fire hazard, which could cause damage to property, serious injury or death.

NOTICE

Avoid filling the tank in rainy or dusty conditions where airborne material can contaminate the fuel.

Contaminated fuel may cause damage to fuel system components.

Fuel Tank Cap

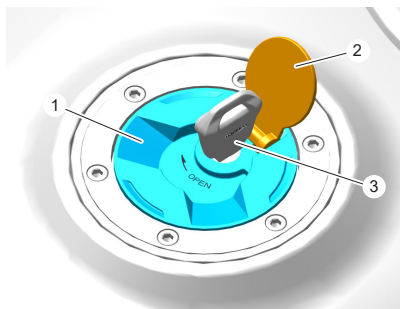

1. Fuel tank cap (Trident 660 shown)
2. Fuel tank cap cover
3. Key

To open the fuel tank cap:

- ▼ Lift up the fuel tank cap cover.
- ▼ Insert the key into the fuel tank cap lock and turn the key clockwise.
- ▼ Remove the fuel tank cap and key.

To close and lock the fuel tank cap:

- ▼ Replace the fuel tank cap with the key inserted and push down until the lock clicks into place.
- ▼ Remove the key and close the fuel tank cap cover.

NOTICE

Closing the fuel tank cap without the key inserted will damage the cap, tank and lock mechanism.

Filling the Fuel Tank

Fill the fuel tank slowly to help prevent spillage. Do not fill the tank to a level above the bottom of the filler neck. This will make sure there is enough air space to allow for fuel expansion if the fuel inside the tank expands through absorption of heat from the engine or from direct sunlight.

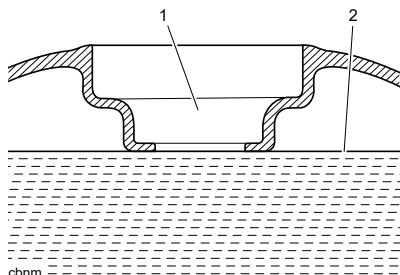

1. Fuel filler neck
2. Maximum fuel level

After refueling always check that the fuel tank cap is correctly closed.

Cruise Control (if equipped)

WARNING

Cruise control must only be used where you can ride safely at a steady speed.

Cruise control should not be used when riding in heavy traffic, on roads with sharp/blind bends or when they are slippery.

Failure to follow the advice above may lead to loss of motorcycle control, which could result in serious injury or death.

WARNING

This motorcycle should be operated within the legal speed limits for the particular road traveled.

Riding a motorcycle at high speeds can be dangerous since the time available to react to a hazard is greatly reduced at high speeds.

Always reduce speed in potentially hazardous driving conditions, such as bad weather or heavy traffic.

Failure to follow the advice above may lead to loss of motorcycle control, which could result in serious injury or death.

NOTICE

Cruise control may not function if there is a malfunction with the ABS and the ABS warning light is illuminated.

GENERAL INFORMATION

The cruise control button is located on the left hand switch housing and can be operated with minimum movement by the rider.

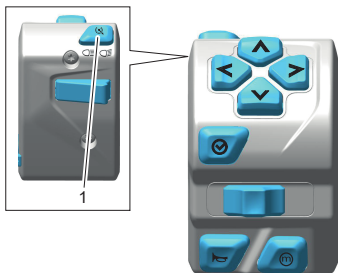

1. Cruise control button (without DRL)

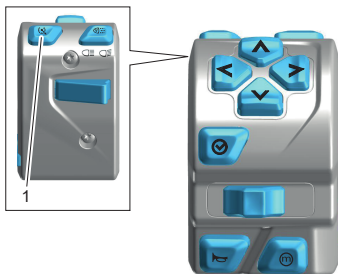

1. Cruise control button (with DRL)

Cruise control can be switched on or off at any time, but it cannot be activated until all the conditions described on page 108 have been met.

Activating Cruise Control

The following conditions must be met to activate cruise control:

- ▼ The motorcycle must be traveling at a speed between 19 to 100 mph (30 to 160 km/h).
- ▼ The motorcycle must be in 2nd gear or higher.

To activate cruise control:

- ▼ Press the cruise control button to turn the cruise control system on. The cruise control indicator light will be shown in amber indicating that the cruise control is on standby.
- ▼ When the required cruising speed is achieved, press the cruise control button again to activate the cruise control. The cruise control light will be shown in green, indicating that the cruise control is active.

Deactivating Cruise Control

Cruise control can be deactivated by one of the following methods:

- ▼ Roll the throttle twist grip fully forward.
- ▼ Pull the clutch lever.
- ▼ Operate the front or rear brake.
- ▼ Increase speed by using the throttle for more than one second.

Upon deactivation, the cruise control indicator light will be shown in amber.

Traction Control (TC)

WARNING

The traction control and optimized cornering traction control systems are not a substitute for riding appropriately for the prevailing surface and weather conditions. The systems cannot prevent loss of traction due to; excessive speed when entering turns, accelerating at a sharp lean angle and braking.

Traction control or optimized cornering traction control cannot prevent the front wheel from slipping.

Failure to follow the advice above may lead to loss of motorcycle control, which could result in serious injury or death.

NOTICE

Traction control will not function if there is a malfunction with the ABS. The warning lights for the ABS, traction control and the MIL will be illuminated.

Traction Control (TC) is a system that helps to maintain traction when accelerating on wet/slippery road surfaces. If sensors detect that the rear wheel is losing traction (slipping), the traction control system will engage and alter the engine power until traction to the rear wheel has been restored.

The traction control indicator light will flash while the system is engaged and the rider may notice a change to the sound of the engine.

Optimized Cornering Traction Control (OCTC) (if equipped)

All Models Except Daytona 660

Optimized Cornering Traction Control (OCTC) is a system designed to give the rider increased control should the Traction Control (TC) be activated while the motorcycle is leaning in a corner.

The system constantly monitors the lean angle of the motorcycle and adapts the level of traction control intervention to maintain rear wheel traction during cornering.

WARNING

If the Traction Control (TC) system is not functioning, care must be taken when accelerating and cornering on wet/slippery road surfaces to avoid rear wheel spin.

In the event of a fault, the TC disabled warning light may be accompanied by the engine management system malfunction indicator light and/or the ABS warning light.

Do not continue to ride for longer than is necessary with any of the above warning lights illuminated. Contact a competent person with the specialist knowledge and technical understanding of motorcycles, such as an authorized Triumph dealer.

Hard acceleration and cornering may cause the rear wheel to spin, leading to loss of motorcycle control which could result in serious injury or death.

GENERAL INFORMATION

WARNING

If a fault occurs with the Optimized Cornering Traction Control (OCTC) system, the TC disabled warning light will illuminate and a message will be shown in the display.

The TC system will continue to operate but without the optimized cornering function, provided that:

- There are no other faults with the TC system.
- TC has NOT been disabled by the rider (see Bike Setup on page 84).

Care must be taken when accelerating and cornering on wet/slippery road surfaces to avoid rear wheel spin.

In the event of a fault, the TC disabled warning light may be accompanied by the engine management system malfunction indicator light and/or the ABS warning light.

Do not continue to ride for longer than is necessary with any of the above warning lights illuminated. The fault must be checked and rectified by a competent person with the specialist knowledge and technical understanding of motorcycles, such as an authorized Triumph dealer.

Hard acceleration and cornering may cause the rear wheel to spin, leading to loss of motorcycle control which could result in serious injury or death.

NOTICE

Optimized cornering traction control may not function if there is a malfunction with the ABS. The warning lights for the ABS, TC and the MIL may be illuminated.

For full details of the TC disabled warning light operation and its associated instrument warning messages, see page 62.

Traction Control Settings

WARNING

Do not attempt to adjust the traction control settings while the motorcycle is in motion.

Adjusting the traction control settings while riding the motorcycle is dangerous.

Failure to follow the advice above may lead to loss of motorcycle control, which could result in serious injury or death.

WARNING

If the traction control is disabled, the motorcycle will handle as normal but without traction control.

In this situation, accelerating too hard on wet/slippery road surfaces may cause the rear wheel to slip.

Failure to follow the advice above may lead to loss of motorcycle control, which could result in serious injury or death.

The traction control system can be disabled as described in Bike Setup on page 84, or set to the conditions described in Riding Mode Configuration on page 82.

If traction control is turned OFF, the TC disabled warning light will be illuminated.

The traction control defaults to ON after the ignition has been switched OFF and then switched ON again.

Tire Pressure Monitoring System (TPMS) (if equipped)

WARNING

The daily check of tire pressures must not be excluded because of the installation of the Tire Pressure Monitoring System (TPMS).

The TPMS is not to be used as a tire pressure gage when adjusting the tire pressures.

For correct tire pressures, always check the tire pressures when the tires are cold using an accurate tire pressure gage.

Use of the TPMS system to set inflation pressures may lead to incorrect tire pressures, leading to loss of motorcycle control, which could result in serious injury or death.

NOTICE

The Tire Pressure Monitoring System (TPMS) is available as an accessory option and must be installed by a competent person with the specialist knowledge and technical understanding of motorcycles, such as an authorized Triumph dealer.

The TPMS display on the instruments will only be activated when the system has been installed.

Tire pressure sensors are mounted to the front and rear wheels. These sensors measure the air pressure inside the tire and transmit pressure data to the instruments. These sensors will not transmit the data until the motorcycle is traveling at a speed greater than 12 mph (20 km/h). Two dashes will be shown in the display area until the tire pressure signal is received.

An adhesive label will be mounted to the wheel rim to indicate the position of the tire pressure sensor, which is near the valve.

Tire Pressures

WARNING

The Tire Pressure Monitoring System (TPMS) is not to be used as a tire pressure gage when adjusting the tire pressures.

For correct tire pressures, always check the tire pressures when the tires are cold using an accurate tire pressure gage.

Use of the TPMS system to set inflation pressures may lead to incorrect tire pressures, leading to loss of motorcycle control, which could result in serious injury or death.

NOTICE

Do not use anti puncture fluid or any other item likely to obstruct air flow to the TPMS sensors' orifices. Any blockage to the air pressure orifice of the TPMS sensor during operation will cause the sensor to become blocked, causing irreparable damage to the TPMS sensor assembly.

Damage caused by the use of anti-puncture fluid or incorrect maintenance is not considered a manufacturing defect and will not be covered under warranty.

Always have the tires mounted by a competent person with the specialist knowledge and technical understanding of motorcycles, such as an authorized Triumph dealer. It is important to inform them that tire pressure sensors are installed on the wheels before they remove the tires.

NOTICE

An adhesive label is installed to the wheel rim to indicate the position of the tire pressure sensor.

Care must be taken when replacing the tires to prevent any damage to the tire pressure sensors.

Always have the tires mounted by a competent person with the specialist knowledge and technical understanding of motorcycles, such as an authorized Triumph dealer. It is important to inform them that tire pressure sensors are installed on the wheels before they remove the tires.

The tire pressures shown on the instrument panel indicate the actual tire pressure at the time of selecting the display. This may differ from the inflation pressure set when the tires are cold because tires become warmer during riding, causing the air in the tire to expand and the pressure to increase. The cold inflation pressures specified by Triumph take account of this.

The tire pressures must only be adjusted when the tires are cold and using an accurate tire pressure gage. The tire pressure display on the instruments must not be used when adjusting the tire pressure. For the recommended tire pressures, see the Specification section.

Tire Pressure Sensor Batteries

When the battery voltage in a pressure sensor is low, a message will be shown in the instrument display and the TPMS symbol or message will indicate which wheel sensor has the low battery voltage.

If the batteries are fully discharged, only dashes will be shown in the instrument display, the red TPMS warning light will be on and the TPMS symbol will flash continuously.

Contact a competent person with the specialist knowledge and technical understanding of motorcycles, such as an authorized Triumph dealer, to have the sensor replaced and the new serial number recorded in the spaces provided in the Motorcycle Service Handbook.

If the TPMS symbol flashes continuously or the TPMS warning light remains on with the ignition turned ON, there is a fault with the TPMS system. The fault must be checked and rectified by a competent person with the specialist knowledge and technical understanding of motorcycles, such as an authorized Triumph dealer.

Tire Pressure Sensor Serial Number

The serial number for the tire pressure sensor is printed on a label attached to the sensor. This number may be required for service or diagnostics.

When the tire pressure monitoring system is being installed on the motorcycle, make sure that the serial numbers of the front and rear tire pressure sensors are recorded in the spaces provided in the Motorcycle Service Handbook.

Replacement Tires

When replacing tires, contact a competent person with the specialist knowledge and technical understanding of motorcycles, such as an authorized Triumph dealer to mount your tires and make sure they are aware that tire pressure sensors are mounted to the wheels.

Stands

Side Stand

WARNING

The motorcycle is equipped with an interlock system to prevent it from being ridden with the side stand in the down position.

Never attempt to ride with the side stand down or interfere with the interlock mechanism, as this will cause a dangerous riding condition.

Failure to follow the advice above may lead to loss of motorcycle control, which could result in serious injury or death.

CAUTION

Do not lean, sit or climb on the motorcycle when it is supported on the side stand.

This may cause the motorcycle to fall over, or cause severe damage to the side stand or motorcycle frame.

Failure to follow the advice above could result in minor to moderate injury.

GENERAL INFORMATION

The motorcycle is equipped with a side stand on which the motorcycle can be parked.

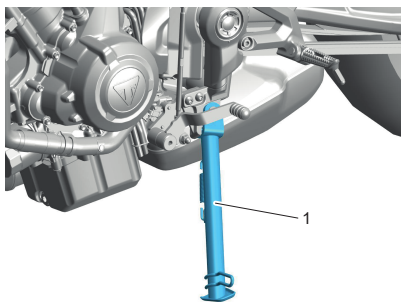

1. Side stand (Trident 660 shown)

When using the side stand, always turn the handlebars fully to the left and leave the motorcycle in first gear.

Whenever the side stand is used, before riding, always make sure that the side stand is fully up after first sitting on the motorcycle.

For instructions on safe parking, refer to the How to Ride the Motorcycle section.

Center Stand (if equipped)

NOTICE

Do not use body panels or the seat as a hand-hold when placing the motorcycle on the center stand as this will cause damage.

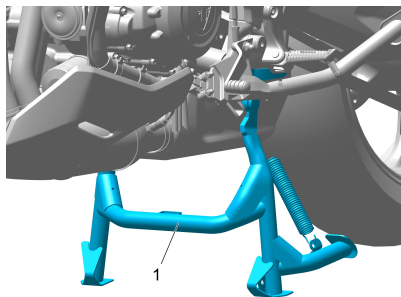

1. Center stand

To set the motorcycle on the center stand, step down firmly on the foot finder part of the stand, then lift the motorcycle up and to the rear using the rear rack as a handhold.

For instructions on safe parking, refer to the How to Ride the Motorcycle section.

Paddock Stand Pegs

Tiger Sport 800 Only

NOTICE

Paddock stand pegs must not be installed on this motorcycle.

It is possible that the paddock stand peg may come into contact with the exhaust muffler, causing damage to both the muffler and the paddock stand peg.

We recommend installing the optional Triumph accessory center stand kit, which is available from your authorized Triumph dealer.

If a paddock stand is to be used, it should be of the type that supports the swinging arm from the underside.

Seats

Seat Care

For seat cleaning information, see page 248.

Seat Lock

WARNING

To prevent detachment of the seat during riding, after installation always grasp the seat and pull firmly upwards.

If the seat is not correctly secured in the lock, it will detach from the lock.

A loose or detached seat may lead to loss of motorcycle control which could result in serious injury or death.

NOTICE

The motorcycle must not be ridden with the key in the seat lock.

Always lock the seat and remove the key before riding the motorcycle.

The seat lock is located on the left hand side of the motorcycle, on the frame below the seat.

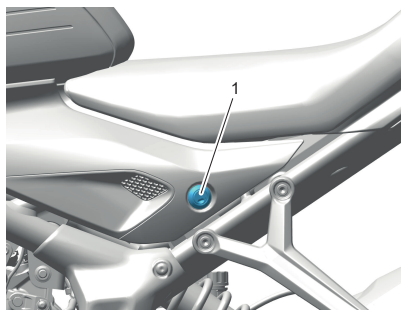

1. Seat lock (Trident 660 shown)

GENERAL INFORMATION

The seat can be removed to gain access to the battery and the fuses.

Seat - Removal

WARNING

Make sure that the motorcycle is stabilized and adequately supported.

Do not support the motorcycle on any ancillary component, the exhaust system or any other non-structural parts of the motorcycle frame.

A correctly supported motorcycle will help prevent it from falling.

Failure to follow the advice above could result in serious injury or death.

NOTICE

To prevent damage to the seats or seat covers, care must be taken not to drop the seats.

Do not lean the seats against the motorcycle or any surface that may damage the seats or seat covers. Instead, place the seats, with the seat cover facing upwards, on a clean, flat surface, which is covered with a soft cloth.

Do not place any item on the seats, which may cause damage or staining to the seat covers.

Trident 660, Trident 660 - Triple Tribute, Tiger Sport 660, Tiger Sport 800 and Tiger Sport 800 Tour

Seat

- ▼ Insert the ignition key into the seat lock and turn it counterclockwise. This will release the seat from its lock and allow it to be slid rearwards for complete removal from the motorcycle.

Daytona 660 and Trident 800

Passenger Seat

NOTICE

The passenger seat must be removed before removing the rider's seat.

- ▼ Insert the ignition key into the seat lock and turn it counterclockwise. This will release the passenger seat from its lock and allow it to be slid forwards for complete removal from the motorcycle.

Rider's Seat

- ▼ Remove the passenger seat as described above.
- ▼ Remove the two fasteners at the rear of the seat.

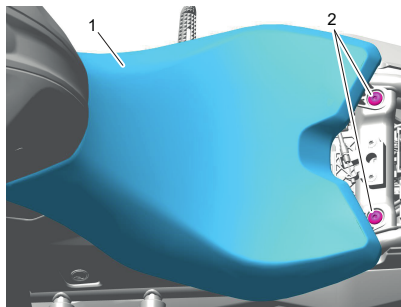

1. Rider's seat

2. Fasteners

- ▼ Lift the seat up from the back and slide rearwards for complete removal from the motorcycle.

Seat - Installation

⚠ WARNING

Make sure that the motorcycle is stabilized and adequately supported.

Do not support the motorcycle on any ancillary component, the exhaust system or any other non-structural parts of the motorcycle frame.

A correctly supported motorcycle will help prevent it from falling.

Failure to follow the advice above could result in serious injury or death.

Trident 660, Trident 660 - Triple Tribute, Tiger Sport 660, Tiger Sport 800 and Tiger Sport 800 Tour

Seat

- ▼ Align the two locating holes at the front of the seat with the locating tangs on the fuel tank brackets.
- ▼ Engage the seat tongue with the seat tongue locating position on the motorcycle.

- ▼ Align the seat lock peg to the lock and press down, engaging the seat lock. An audible click can be heard when the seat is fully engaged in its lock.

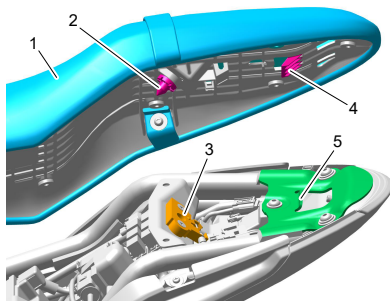

1. Seat
2. Seat lock peg
3. Seat lock
4. Seat tongue
5. Seat tongue locating position

⚠ WARNING

To prevent detachment of the seat during riding, after installation always grasp the seat and pull firmly upwards.

If the seat is not correctly secured in the lock, it will detach from the lock.

A loose or detached seat may lead to loss of motorcycle control which could result in serious injury or death.

- ▼ Grasp the seat and pull firmly upwards to ensure that it is securely retained.

GENERAL INFORMATION

Seat

- ▼ Align the two locating slots at the front of the seat with the locating tangs on the frame.
- ▼ Engage the seat tongue with the seat tongue locating position on the fuel tank rear panel.

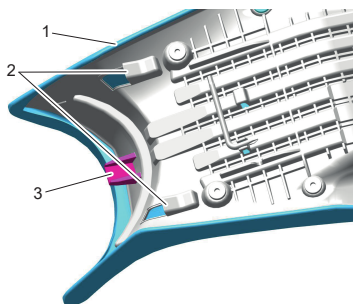

1. Seat
2. Locating slots
3. Seat tongue

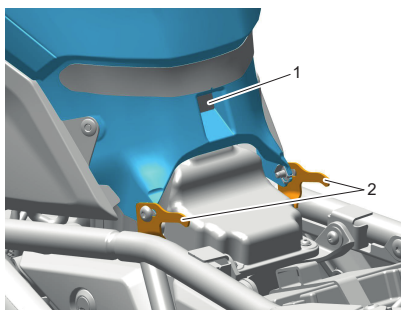

1. Seat tongue locating position (Tiger Sport 660 shown)
2. Locating tangs

- ▼ Align the seat lock peg to the lock and press down, engaging the seat lock. An audible click can be heard when the seat is fully engaged in its lock.

⚠ WARNING

To prevent detachment of the seat during riding, after installation always grasp the seat and pull firmly upwards.

If the seat is not correctly secured in the lock, it will detach from the lock.

A loose or detached seat may lead to loss of motorcycle control which could result in serious injury or death.

- ▼ Grasp the seat and pull firmly upwards to ensure that it is securely retained.

Daytona 660 and Trident 800

Rider's Seat

- ▼ Align the two locating slots at the front of the seat with the locating tangs on the frame.
- ▼ Lower the rear of the seat and align the holes for the fasteners.
- ▼ Install the two fasteners at the rear of the seat and tighten to 44 lbf in (44 lbf in (5 Nm)).

⚠ WARNING

Never ride the motorcycle with the fasteners loose or removed, as the rider's seat will not be secure and can move.

The rider's seat is only correctly retained and supported when the fasteners are correctly tightened.

A loose or detached seat may lead to loss of motorcycle control which could result in serious injury or death.

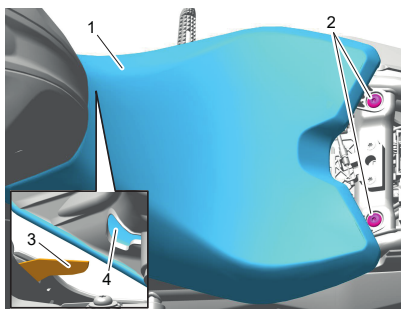

1. Rider's Seat
2. Fasteners
3. Locating tangs (right hand side shown)
4. Locating slots (right hand side shown)

- ▼ Grasp the seat and pull firmly upwards to make sure it is securely retained.
- ▼ Install the passenger seat as follows.

GENERAL INFORMATION

Passenger Seat

- ▼ Engage the seat tongue with the seat tongue locating position on the motorcycle.
- ▼ Align the seat lock peg to the lock and press down, engaging the seat lock. An audible click can be heard when the seat is fully engaged in its lock.

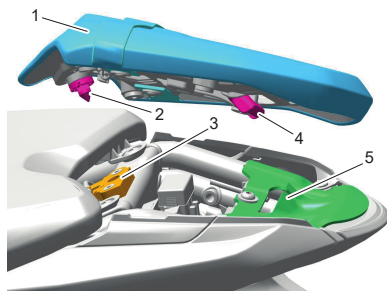

1. Passenger seat
2. Seat lock peg
3. Seat lock
4. Seat tongue
5. Seat tongue locating position

⚠ WARNING

To prevent detachment of the seat during riding, after installation always grasp the seat and pull firmly upwards.

If the seat is not correctly secured in the lock, it will detach from the lock.

A loose or detached seat may lead to loss of motorcycle control which could result in serious injury or death.

- ▼ Grasp the seat and pull firmly upwards to ensure that it is securely retained.

Fairings

NOTICE

To prevent damage to the fairings, care must be taken not to drop or lean a fairing against any surface which may damage the fairing.

Put the fairing on a clean, flat surface which is covered with a soft cloth.

Do not place any item on the fairing which may cause damage.

Fairings - Removal

Daytona 660 Only

WARNING

Make sure that the motorcycle is stabilized and adequately supported.

Do not support the motorcycle on any ancillary component, the exhaust system or any other non-structural parts of the motorcycle frame.

A correctly supported motorcycle will help prevent it from falling.

Failure to follow the advice above could result in serious injury or death.

NOTICE

Only the left hand fairing needs to be removed to change the engine oil and oil filter.

To remove the left hand fairing:

- ▼ Remove the rider and passenger seats, see page 116.
- ▼ Disconnect the battery leads, negative (black) lead first and then the positive lead, see page 222.
- ▼ Detach the top of the deflector fairing away from the motorcycle until it is free from the retaining grommet (leaving the grommet in place) and clip.
- ▼ Slide the deflector fairing downwards to detach it from its retaining tang.

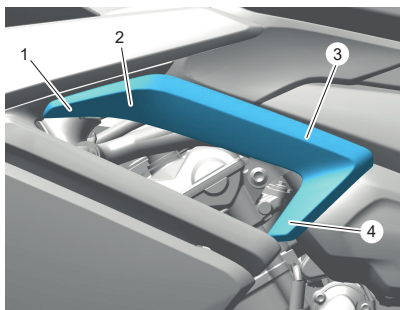

1. Deflector fairing
2. Retaining grommet location
3. Retaining clip location
4. Retaining tang location

NOTICE

Note the position of the front end of the cockpit infill panel for installation.

- ▼ Remove the push release plastic rivet securing the cockpit infill panel to the fairing.

- ▼ Lift the lower edge of the cockpit infill panel to loosen it from its two retaining clips.
- ▼ Slide the cockpit infill panel rearwards for removal.

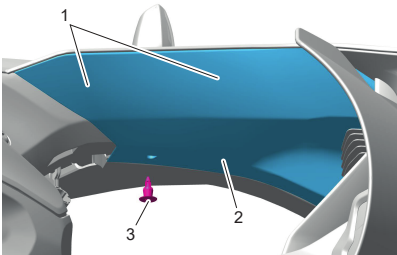

1. Retaining clips location
2. Cockpit infill panel
3. Push release plastic rivet

- ▼ Remove the fastener securing the top of the fairing to the fuse box mounting bracket.

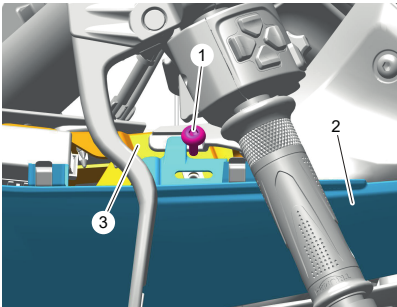

1. Fastener
2. Fairing
3. Fuse box mounting bracket

- ▼ Remove the five push release plastic rivets and remove the infill panel.

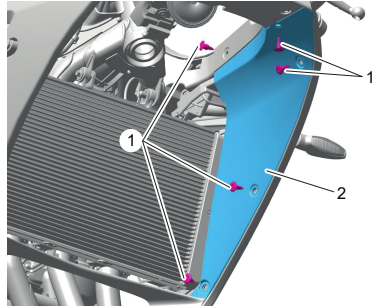

1. Push release plastic rivets
2. Infill panel

- ▼ Remove the fastener securing the fairing to the center infill panel.

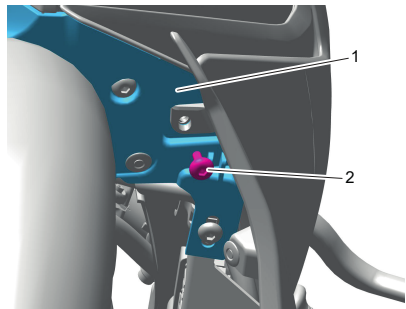

1. Center infill panel
2. Fastener

- ▼ Remove the push release plastic rivet securing the lower infill panel to the fairing.

- ▼ Remove the upper fastener.

GENERAL INFORMATION

- ▼ Remove the two lower fasteners securing the fairing lower halves to each other.

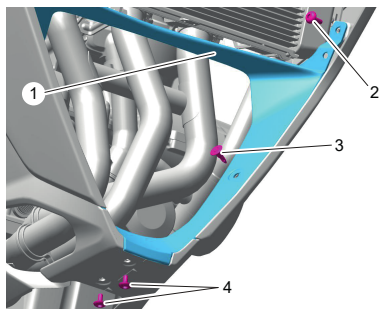

1. Lower infill panel
2. Upper fastener
3. Push release plastic rivet
4. Lower fasteners

- ▼ Remove the fastener from the rear of the fairing.
- ▼ Detach the fairing from the cockpit.
- ▼ Detach the fairing from the fuel tank infill panel.

- ▼ Slide the fairing forwards to detach it from its retaining bracket.

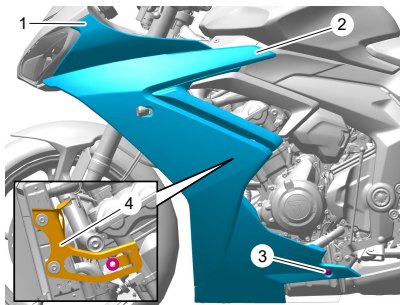

1. Retaining clips location (cockpit)
2. Retaining grommet location (fuel tank infill panel)
3. Fastener
4. Retaining bracket with grommet

NOTICE

Note the routing of the turn signal harness for installation.

- ▼ Disconnect the turn signal from the main harness.

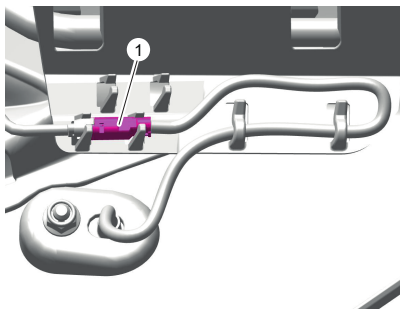

1. Turn signal connector
- ▼ Remove the fairing.

Fairings - Installation

Daytona 660 Only

WARNING

Make sure that the motorcycle is stabilized and adequately supported.

Do not support the motorcycle on any ancillary component, the exhaust system or any other non-structural parts of the motorcycle frame.

A correctly supported motorcycle will help prevent it from falling.

Failure to follow the advice above could result in serious injury or death.

To install the left hand fairing:

- ▼ Route the turn signal harness as noted for removal and connect to the main harness.

NOTICE

Before installing the fairing, make sure the grommet is mounted to the retaining bracket.

While installing the fairing, make sure the fairing top bracket is located above the fuel tank infill panel.

- ▼ Slide the fairing rearwards to attach the locating feature onto its retaining bracket.

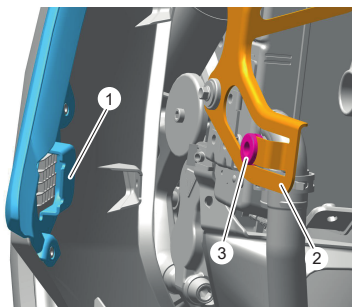

1. Fairing locating feature
2. Retaining bracket
3. Grommet

- ▼ Attach the fairing to the fuel tank infill panel.
- ▼ Attach the fairing to the cockpit.
- ▼ Install the fastener to the rear of the fairing. Do not tighten at this stage.

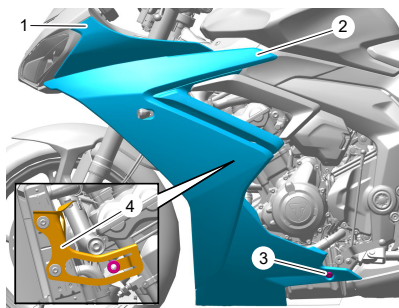

1. Retaining clips location (cockpit)
2. Retaining grommet location (fuel tank infill panel)
3. Fastener
4. Retaining bracket with grommet

- ▼ Install the two lower fasteners securing the fairing lower halves to each other and tighten to 27 lbf in (3 Nm).

GENERAL INFORMATION

- ▼ Install the upper fastener securing the lower infill panel to the fairing and tighten to 27 lbf in (3 Nm).
- ▼ Install the push release plastic rivet.

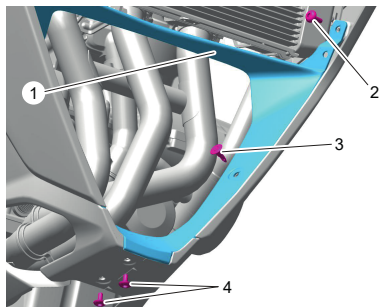

1. Lower infill panel
2. Upper fastener
3. Push release plastic rivet
4. Lower fasteners

- ▼ Install the fastener securing the fairing to the center infill panel and tighten to 27 lbf in (3 Nm).

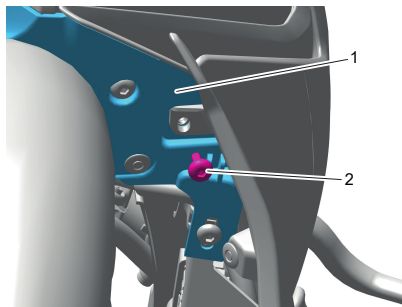

1. Center infill panel
2. Fastener

- ▼ Install the five push release plastic rivets securing the infill panel to the fairing.

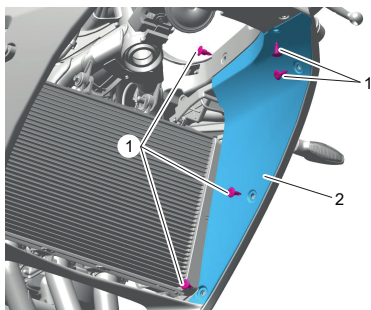

1. Push release plastic rivets
2. Infill panel

- ▼ Install the fastener securing the top of the fairing to the fuse box mounting bracket and tighten to 27 lbf in (3 Nm).

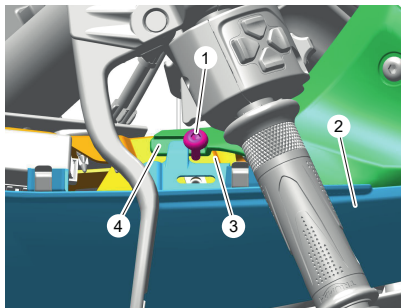

1. Fastener
2. Fairing
3. Fuse box mounting bracket
4. Fuel tank infill panel

- ▼ Install the front end of cockpit infill panel as noted for removal and slide the lugs into the two retaining clips.

GENERAL INFORMATION

- ▼ Install the push release plastic rivet securing the cockpit infill panel to the fairing.

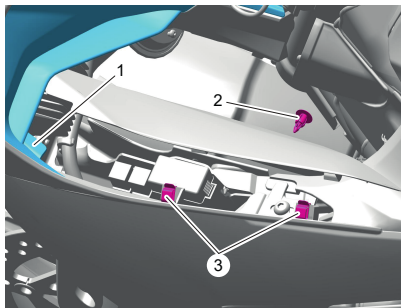

1. Cockpit infill panel locating feature
2. Push release plastic rivet
3. Retaining clips

- ▼ Position the deflector fairing locating feature onto the retaining tang and press the panel into the retaining grommet and clip.

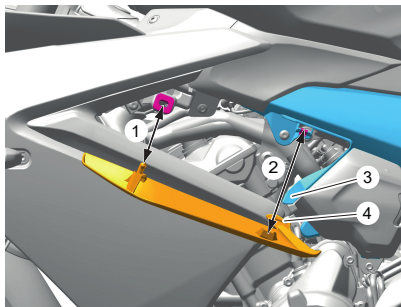

1. Retaining grommet
 2. Retaining clip
 3. Retaining tang
 4. Locating feature
- ▼ Tighten the rear fastener of the fairing to 27 lbf in (3 Nm).
 - ▼ Connect the battery leads, positive (red) lead first and then the negative lead, see page 226.
 - ▼ Install the rider and passenger seats, see page 117.

GENERAL INFORMATION

Luggage Systems

Panniers - Operation

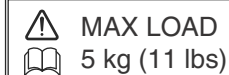

WARNING

The maximum safe load for each pannier is stated on a label inside the pannier and must not be exceeded.

Exceeding this loading limit may affect the handling, stability or other aspects of the motorcycle operation.

Failure to follow the advice above may lead to loss of motorcycle control, which could result in serious injury or death.

- ▼ To open the pannier lid, turn the key to the UNLOCK position.
- ▼ Lift the pannier lid latch lever and move it towards the lid to detach it from the pannier lid.

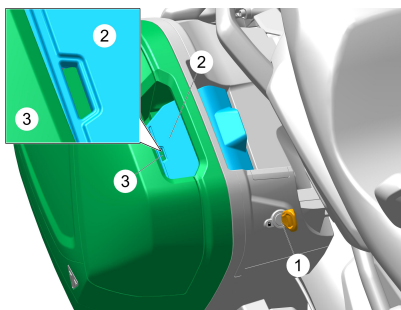

1. UNLOCK position
2. Pannier lid latch lever
3. Pannier lid (held by the release handle)

NOTICE

When the pannier lid is correctly closed and locked there should be no color section visible on the pannier lid latch lever.

If the color section is visible, the lid is not secured in the closed position.

- ▼ Close the pannier lid.
- ▼ Position the pannier lid latch lever over the lid, press down the latch lever on the pannier side to secure the lid.
- ▼ Check that the color section of the lid latch lever is not visible.

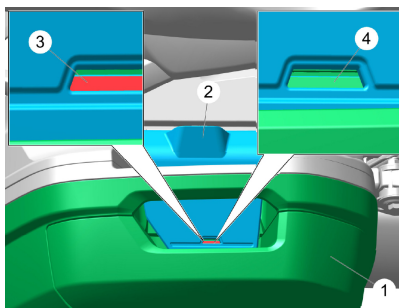

1. Pannier lid
2. Pannier lid latch lever
3. Color section (Not secured)
4. Same color as lid (secured)

- ▼ Before riding, always make sure that the panniers are mounted correctly and that the lock barrel is turned to the LOCK position and the key removed.

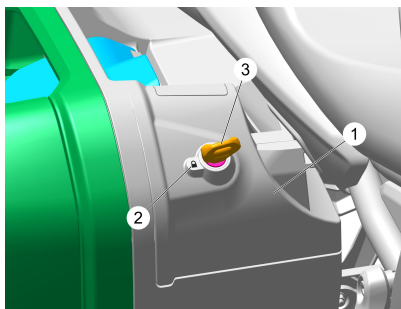

1. Pannier
2. LOCK position
3. Key

⚠ WARNING

After mounting or removing the panniers, operate the motorcycle in a safe area free from traffic to gain familiarity with the new handling characteristics.

Operation when not familiar with the new characteristics of the motorcycle may result in loss of motorcycle control and an accident.

Failure to follow the advice above could result in serious injury or death.

Cleaning the Luggage System

All parts of the luggage system mounted to your motorcycle must be cleaned regularly to avoid deterioration of their appearance.

Washing

Prepare a mixture of cold water and mild automotive cleaner. Do not use a highly alkaline soap as commonly found at commercial car washes because it leaves a residue.

Wash the luggage system with a soft cloth. Do not use an abrasive scouring pad or steel wool. They will damage the finish.

Rinse the luggage system thoroughly.

Make sure that no soap or water enters the inside compartment.

Dry the luggage system as far as possible with a soft cloth.

Protecting

When the luggage system is dry, protect with a colorless lubricating spray.

NOTICE

The use of abrasive cleaners and polishes will damage the system and must not be used.

It is recommended that regular protection is applied to the system as this will both protect and enhance the system's appearance.

It is recommended to use the Triumph inner bags to protect both the luggage contents and the inner surfaces of the luggage.

GENERAL INFORMATION

Panniers - Removal



MAX LOAD

5 kg (11 lbs)

WARNING

After mounting or removing the panniers, operate the motorcycle in a safe area free from traffic to gain familiarity with the new handling characteristics.

Operation when not familiar with the new characteristics of the motorcycle may result in loss of motorcycle control and an accident.

Failure to follow the advice above could result in serious injury or death.

NOTICE

The same procedure can be followed to remove and mount the left hand or the right hand panniers.

- ▼ Insert the key in to the lock and turn to the UNLOCK position.

- ▼ Lift the latch handle at the front of the pannier to retract the locking mechanism.

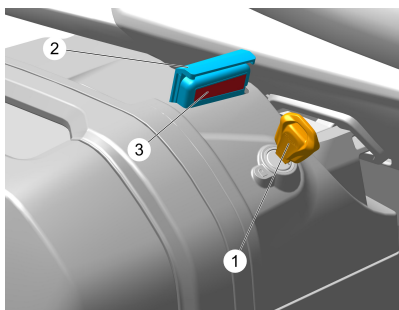

1. Key (UNLOCK position)
2. Latch handle
3. Color section

- ▼ Slide the pannier rearwards clear of the third mount.

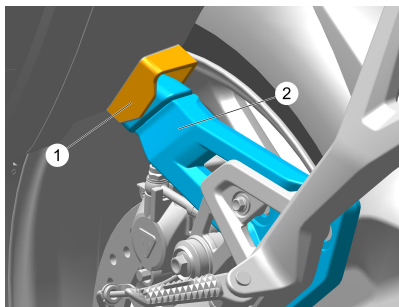

1. Pannier bottom mount
2. Third mount

- ▼ The pannier can now be removed from the motorcycle.

Panniers - Installation



MAX LOAD
5 kg (11 lbs)

WARNING

To prevent detachment of a pannier while riding, after mounting always grasp the pannier and pull firmly outwards and to the rear.

If the pannier is not correctly secured, it will detach from the pannier mounts on the motorcycle.

A loose or detached pannier may cause loss of motorcycle control which could result in serious injury or death.

NOTICE

The panniers must be in the locked condition while riding the motorcycle.

- ▼ Insert the key in to the lock and turn to the UNLOCK position.
- ▼ Lift the latch handle at the front of the pannier to retract the locking mechanism.

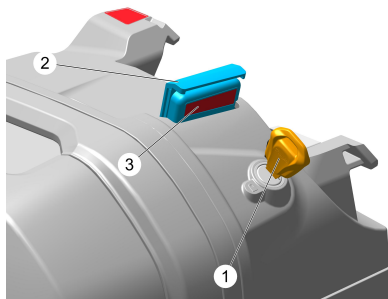

1. Key (UNLOCK position)
2. Latch handle
3. Color section

- ▼ Mount the pannier to the motorcycle making sure the upper pannier mounts are pushed fully into the pannier mounts on the motorcycle.

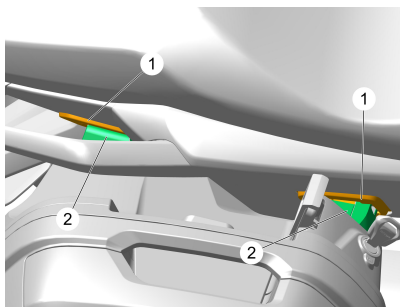

1. Pannier mounts, motorcycle
2. Upper pannier mounts, pannier

- ▼ Slide the pannier forwards making sure the pannier bottom mount locates onto the third mount.

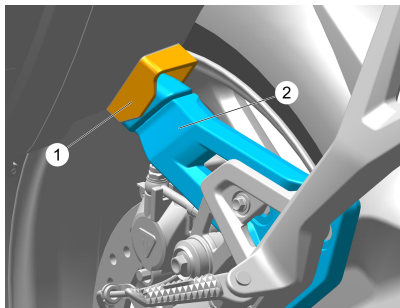

1. Pannier bottom mount
2. Third mount

NOTICE

When the pannier is correctly installed there should be no color section visible at the rear pannier mounting.

GENERAL INFORMATION

- ▼ Check to make sure the pannier rear mounting is correctly installed.

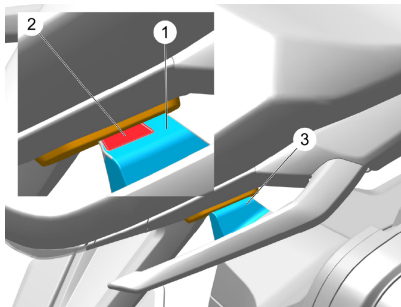

1. Pannier rear mounting
2. Color section (pannier not secure)
3. Rear mounting correctly installed

- ▼ Press the latch handle fully in to the pannier. The color section on the latch handle should not be visible when the pannier is correctly installed.
- ▼ To lock the pannier latch handle, turn the lock barrel to the LOCK position and remove the key.

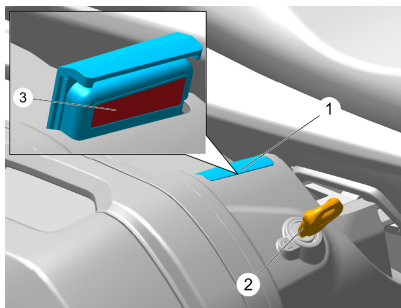

1. Latch handle
2. Key (LOCK position)
3. Color section

Twin Helmet Top Box - Operation

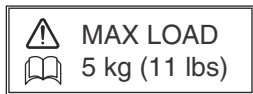

WARNING

An incorrectly mounted top box may detach while riding, resulting in a dangerous riding condition.

Before riding, always make sure that the top box is mounted correctly. Make sure that the lock barrel is turned to the LOCK position and the key removed.

Failure to follow the advice above may lead to loss of motorcycle control, which could result in serious injury or death.

WARNING

The maximum safe load for the top box is 11 lbs (5 kg).

Never exceed the maximum safe load as this may cause the motorcycle to become unstable.

Failure to follow the advice above may lead to loss of motorcycle control, which could result in serious injury or death.

The top box lock has two positions, LOCK and UNLOCK. Insert the key in the lock and turn to the UNLOCK position.

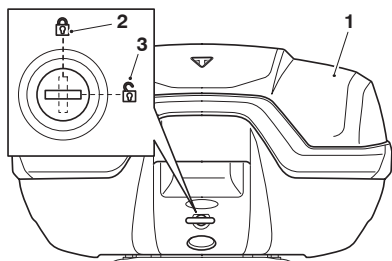

1. Top box
2. Lock, LOCK position
3. Lock, UNLOCK position

- ▼ To open the top box lid, insert the key in to the lock and turn to the UNLOCK position.
- ▼ Press the button above the lock to open the lid.

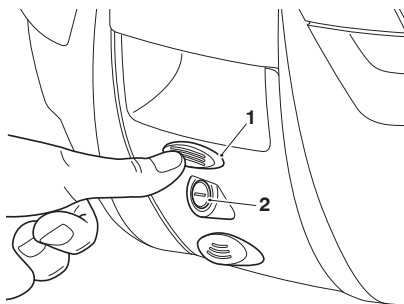

1. Top button
2. Lock

- ▼ Close the lid and turn the key to the LOCK position and remove the key.

Cleaning the Luggage System

All parts of the luggage system mounted to your motorcycle must be cleaned regularly to avoid deterioration of their appearance.

Washing

Prepare a mixture of cold water and mild automotive cleaner. Do not use a highly alkaline soap as commonly found at commercial car washes because it leaves a residue.

Wash the luggage system with a soft cloth. Do not use an abrasive scouring pad or steel wool. They will damage the finish.

Rinse the luggage system thoroughly.

Make sure that no soap or water enters the inside compartment.

Dry the luggage system as far as possible with a soft cloth.

Protecting

When the luggage system is dry, protect with a colorless lubricating spray.

NOTICE

The use of abrasive cleaners and polishes will damage the system and must not be used.

It is recommended that regular protection is applied to the system as this will both protect and enhance the system's appearance.

It is recommended to use the Triumph inner bags to protect both the luggage contents and the inner surfaces of the luggage.

GENERAL INFORMATION

Twin Helmet Top Box - Removal



MAX LOAD



5 kg (11 lbs)

WARNING

An incorrectly mounted top box may detach while riding, resulting in a dangerous riding condition.

Before riding, always make sure that the top box is mounted correctly. Make sure that the lock barrel is turned to the LOCK position and the key removed.

Failure to follow the advice above may lead to loss of motorcycle control, which could result in serious injury or death.

WARNING

The maximum safe load for the top box is 11 lbs (5 kg).

Never exceed the maximum safe load as this may cause the motorcycle to become unstable.

Failure to follow the advice above may lead to loss of motorcycle control, which could result in serious injury or death.

The top box lock has two positions, LOCK and UNLOCK. Insert the key in to the lock and turn to the UNLOCK position.

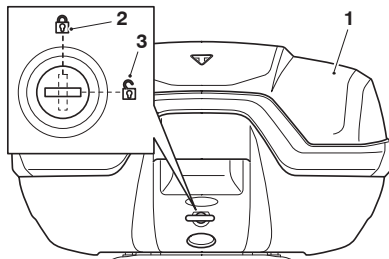

1. Top box
2. Lock, LOCK position
3. Lock, UNLOCK position

- ▼ To remove the top box from the mount platform, insert the key in to the lock and turn the key to the UNLOCK position.
- ▼ Press the button below the lock on the top box, this will release the top box from the mount platform.

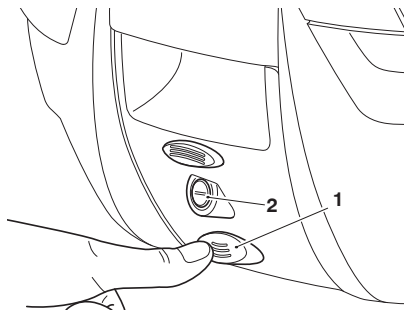

1. Bottom button
2. Lock

- ▼ Lift the rear of the top box to release the locking mechanism from the rear latch.

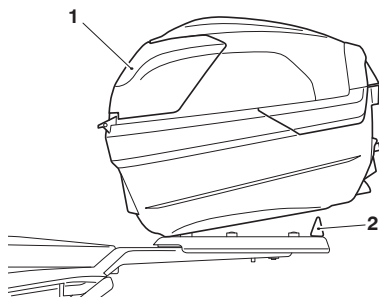

1. Top box
2. Latch

- ▼ Slide the top box rearward to disengage the front pegs and lift the top box away from the mounting plate.

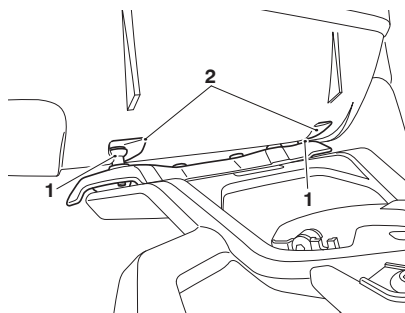

1. Mounting slots
2. Pegs

Top Box Installation

- ▼ Position the top box such that the mounting slots on the bottom of the top box locate with the pegs on the top box mounting plate.

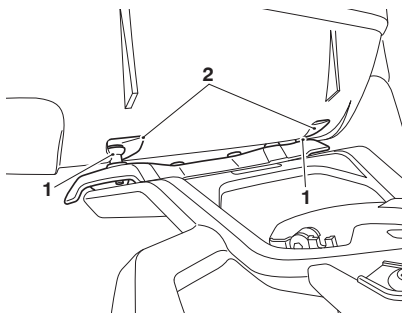

1. Mounting slots
2. pegs

NOTICE

The top box will lock to the mounting plate when the latch on the mounting plate aligns to the locking mechanism of the top box.

- ▼ Push the top box forwards against the pegs and lower the rear of the top box until the locking mechanism engages with the rear latch.

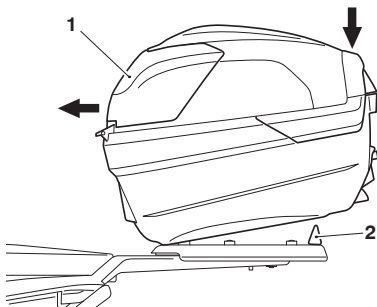

1. Top box
2. Latch

GENERAL INFORMATION

NOTICE

An audible click can be heard when the locking mechanism on the top box is correctly latched to the top box mounting plate.

If an audible click cannot be heard the top box may not be correctly latched to the top box mounting plate.

- ▼ Lock the top box to the top box mounting plate by pushing downwards to fully engage it.

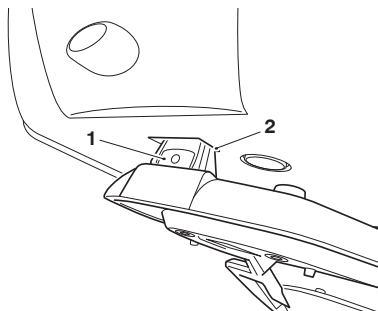

1. Latch
2. Locking mechanism

NOTICE

There must not be any movement between the top box and top box mounting plate when the top box is correctly secured.

The top box must be in the locked condition while riding the motorcycle.

- ▼ Check the top box is secure by pulling the top box firmly upwards and to the rear. If the top box is not correctly secured remove and reinstall.
- ▼ To lock the top box onto the top box mount assembly, insert the key in the lock and turn to the LOCK position, as shown below. Note, this will also lock the top box lid.

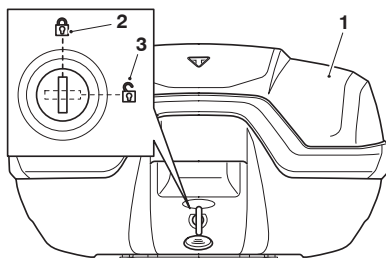

1. Top box
2. Lock, LOCK position
3. Lock, UNLOCK position

- ▼ Check that the top box is securely locked to the top box mount assembly.

Top Box Release Mechanism Lubrication

NOTICE

Periodic lubrication of the top box release mechanism is advised to maintain a reliable and trouble free operation of the release mechanism.

- ▼ Open the top box lid and locate the four fasteners retaining the latch housing to the top box. While supporting the latch housing, remove the fasteners. Retain the fasteners for reuse.

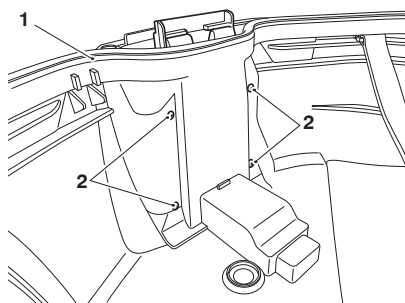

1. Top Box
2. Fasteners

- ▼ Remove the latch housing from the top box by moving the lower edge of the housing out from the top box to clear the release button, then move the latch housing down and away from the top box.

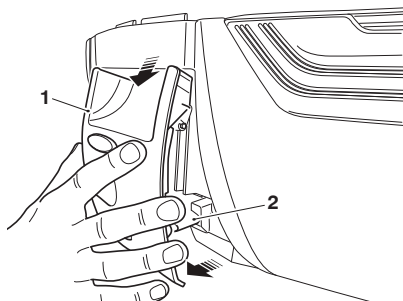

1. Latch housing
2. Release button

- ▼ Remove the release button from the top box. Retain the release button for reuse.

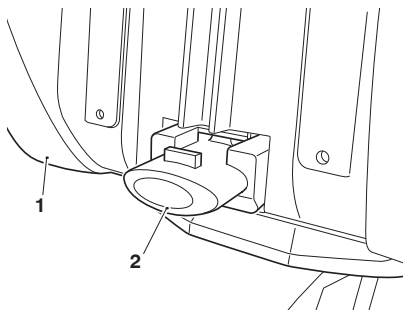

1. Top box
2. Release button

GENERAL INFORMATION

- ▼ Apply lubricant to the sides of the top box release mechanism.

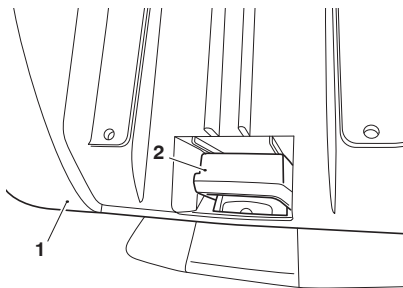

1. Top box
2. Release mechanism

- ▼ Remount the release button and latch housing to the top box using the original fasteners. Tighten the fasteners to 13 lbf in (1.5 Nm).

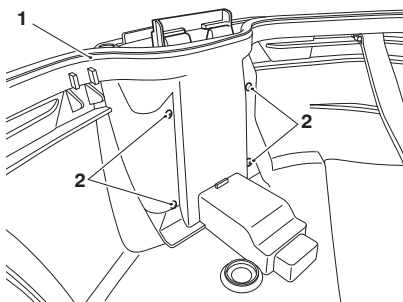

1. Top box
2. Fasteners

Cleaning the Luggage System

All parts of the luggage system mounted to your motorcycle must be cleaned regularly to avoid deterioration of their appearance.

Washing

Prepare a mixture of cold water and mild automotive cleaner. Do not use a highly alkaline soap as commonly found at commercial car washes because it leaves a residue.

Wash the luggage system with a soft cloth. Do not use an abrasive scouring pad or steel wool. They will damage the finish.

Rinse the luggage system thoroughly.

Make sure that no soap or water enters the inside compartment.

Dry the luggage system as far as possible with a soft cloth.

Protecting

When the luggage system is dry, protect with a colorless lubricating spray.

NOTICE

The use of abrasive cleaners and polishes will damage the system and must not be used.

It is recommended that regular protection is applied to the system as this will both protect and enhance the system's appearance.

It is recommended to use the Triumph inner bags to protect both the luggage contents and the inner surfaces of the luggage.

Twin Helmet Top Box - Installation



MAX LOAD

5 kg (11 lbs)

WARNING

An incorrectly mounted top box may detach while riding, resulting in a dangerous riding condition.

Before riding, always make sure that the top box is mounted correctly. Make sure that the lock barrel is turned to the LOCK position and the key removed.

Failure to follow the advice above may lead to loss of motorcycle control, which could result in serious injury or death.

- ▼ Position the top box such that the mounting slots on the bottom of the top box locate with the pegs on the top box mounting plate.

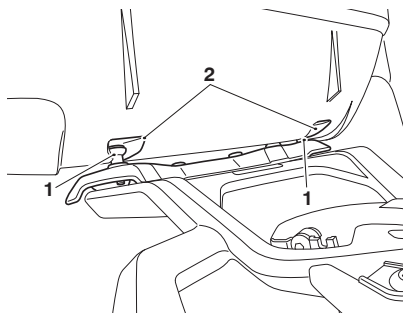

1. Mounting slots
2. Pegs

NOTICE

The top box will lock to the mounting plate when the latch on the mounting plate aligns to the locking mechanism of the top box.

- ▼ Push the top box forwards against the pegs and lower the rear of the top box until the locking mechanism engages with the rear latch.

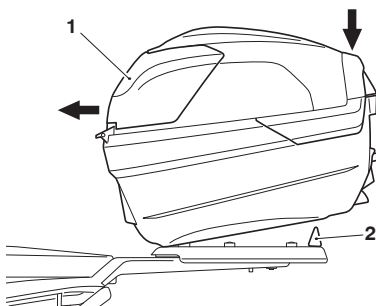

1. Top box
2. Latch

NOTICE

An audible click can be heard when the locking mechanism on the top box is correctly latched to the top box mounting plate.

If an audible click cannot be heard the top box may not be correctly latched to the top box mounting plate.

GENERAL INFORMATION

- ▼ Lock the top box to the top box mounting plate by pushing downwards to fully engage it.

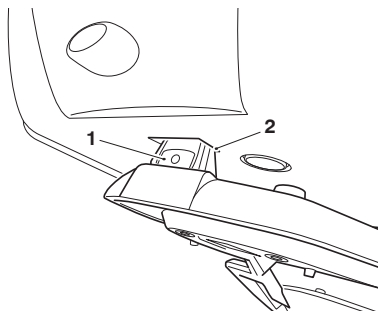

1. Latch
2. Locking mechanism

NOTICE

There must not be any movement between the top box and top box mounting plate when the top box is correctly secured.

The top box must be in the locked condition while riding the motorcycle.

- ▼ Check the top box is secure by pulling the top box firmly upwards and to the rear. If the top box is not correctly secured remove and reinstall.
- ▼ To lock the top box onto the top box mount assembly, insert the key in to the lock and turn to the LOCK position, as shown below. Note, this will also lock the top box lid.

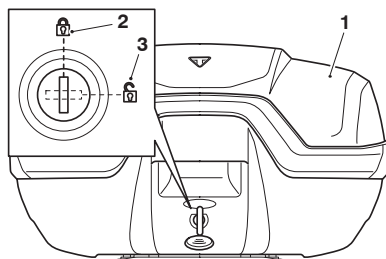

1. Top box
2. Lock, LOCK position
3. Lock, UNLOCK position

- ▼ Check that the top box is securely locked to the top box mount assembly.

Twin Helmet Top Box - Release Mechanism Lubrication



MAX LOAD



5 kg (11 lbs)

NOTICE

Periodic lubrication of the top box release mechanism is advised to maintain a reliable and trouble-free operation of the release mechanism.

- ▼ Open the top box lid and locate the four fasteners retaining the latch housing to the top box. While supporting the latch housing, remove the fasteners. Retain the fasteners for reuse.

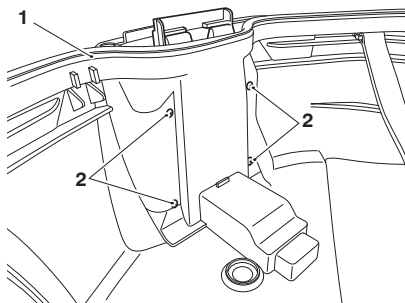

1. Top Box
2. Fasteners

GENERAL INFORMATION

- ▼ Remove the latch housing from the top box by moving the lower edge of the housing out from the top box to clear the release button, then move the latch housing down and away from the top box.

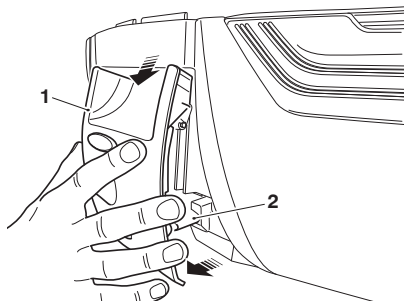

1. Latch housing
2. Release button

- ▼ Remove the release button from the top box. Retain the release button for reuse.

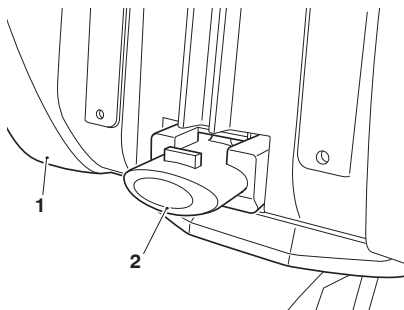

1. Top box
2. Release button

GENERAL INFORMATION

- ▼ Apply lubricant to the sides of the top box release mechanism.

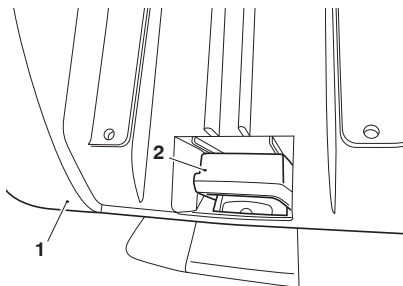

1. Top box
2. Release mechanism

- ▼ Remount the release button and latch housing to the top box using the original fasteners. Tighten the fasteners to 13 lbf in (1.5 Nm).

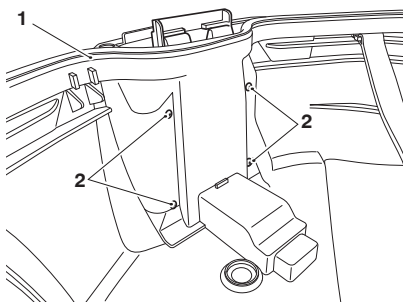

1. Top box
2. Fasteners

Windshield (if equipped)

⚠ WARNING

Never attempt to clean the windshield while riding the motorcycle.

Removal of the rider's hands from the handlebars while riding the motorcycle will diminish the ability of the rider to maintain the control of the motorcycle.

Attempting to clean the windshield while riding the motorcycle may lead to loss of motorcycle control, which could result in serious injury or death.

⚠ WARNING

Make sure that the windshield is adjusted to the same position on both sides.

Riding the motorcycle with an incorrectly adjusted windshield may affect the handling, stability or other aspect of the motorcycle operation.

Failure to follow the advice above may lead to loss of motorcycle control, which could result in serious injury or death.

GENERAL INFORMATION

The windshield installed on the Tiger Sport 660 and Tiger Sport 800 can be manually adjusted without the use of tools.

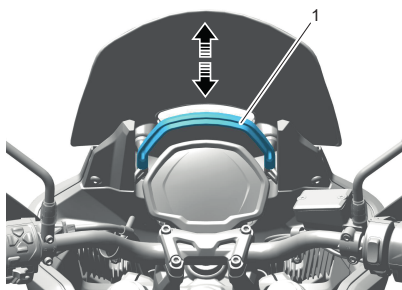

1. Height adjustment handle (Tiger Sport 660 shown)

To adjust the windshield height:

- ▼ Safely sit on the motorcycle.
- ▼ Firmly grip the height adjustment handle.
- ▼ Move the handle up or down to adjust the windshield to the required height.

For windshield cleaning information, see page 248.

Owner's Handbook and Tool Kit

Owner's Handbook/Quick Start Guide

The Owner's Handbook or Quick Start Guide is supplied with the motorcycle.

Tool Kit

Trident 660 and Trident 660 - Triple Tribute

There is an Allen key located on the underside of the seat.

A tool kit is supplied with the motorcycle which includes a C-spanner and extension handle.

Tiger Sport 660, Tiger Sport 800 and Tiger Sport 800 Tour

There is an Allen key located on the underside of the seat.

Daytona 660

There is an Allen key located on the underside of the passenger seat.

A tool kit is supplied with the motorcycle which includes a C-spanner and extension handle.

Breaking-In



Breaking-in is the name given to the process that occurs during the first hours of a new vehicle's operation.

In particular, internal friction in the engine will be higher when components are new. Later on, when continued operation of the engine has ensured that the components have 'bedded in', this internal friction will be greatly reduced.

A period of careful breaking-in will ensure lower exhaust emissions, and will optimize performance, fuel economy and longevity of the engine and other motorcycle components.

During the first 600 miles (1,000 km):

- ▼ Do not use full throttle.
- ▼ Avoid high engine speeds at all times.
- ▼ Avoid riding at one constant engine speed, whether fast or slow, for a long period of time.
- ▼ Avoid aggressive starts, stops, and rapid accelerations, except in an emergency.
- ▼ Do not ride at speeds greater than 3/4 of maximum engine speed.

From 600 to 1,000 miles (1,000 to 1,500 km):

- ▼ Engine speed can gradually be increased to the maximum engine speed for short periods.

Both during and after breaking-in has been completed:

- ▼ Do not over-rev the engine when cold.
- ▼ Do not lug the engine. Always downshift before the engine begins to 'struggle'.
- ▼ Do not ride with engine speeds unnecessarily high. Shifting up a gear helps reduce fuel consumption, reduces noise and helps to protect the environment.

Daily Safety Checks



WARNING

Always perform the daily safety checks every day before you ride the motorcycle.

Failure to perform these daily safety checks may lead to loss of motorcycle control, which could result in motorcycle damage, serious injury or death.

Check the following items each day before you ride. The time required is minimal, and these checks will help make sure you have a safe, reliable ride.

If any irregularities are found during these checks, refer to the Maintenance and Adjustment section or contact a competent person with the specialist knowledge and technical understanding of motorcycles, such as an authorized Triumph dealer, for the action required to return the motorcycle to a safe operating condition.

Check:

Fuel: Adequate supply in tank, no fuel leaks (see page 104).

Engine Oil: Correct level on dipstick. Add correct specification oil as required. No leaks from the engine or oil cooler (see page 174).

Drive Chain: Correct adjustment (see page 189).

Tires/Wheels: Correct inflation pressures (when cold). Tread depth/wear, tire/wheel damage, punctures etc. (see page 216).

Nuts, Bolts, Fasteners: Visually check that steering and suspension components, axles, and all controls are properly tightened or fastened. Inspect all areas for loose/damaged fasteners.

Steering Action: Smooth but not loose from lock to lock. No binding of any of the control cables (see page 204).

Brakes: Pull the brake lever and push the brake pedal to check for correct resistance. Investigate any lever/pedal where the travel is excessive before meeting resistance, or if either control feels spongy in operation (see page 195).

Brake Pads: Check that the correct amount of friction material is remaining on all the brake pads (see page 196).

GENERAL INFORMATION

Brake Fluid Levels: No brake fluid leakage. Brake fluid levels must be between the MAX and MIN marks on both reservoirs (see page 198).

Front Forks: Smooth action. No fork oil leakage (see page 207).

Throttle: Make sure that the throttle grip returns to the idle position without sticking (see page 95).

Clutch: Smooth operation and correct cable free play (see page 186).

Coolant: No coolant leakage. Check the coolant level in the expansion tank (when the engine is cold) (see page 182).

Electrical Equipment: All lights and the horn function correctly (see page 100).

Engine Stop: Engine start/stop switch turns the engine OFF when the switch is moved to the STOP position (see page 99).

Stands: Returns to the fully up position by spring tension. Return springs not weak or damaged (see page 113).

Table of Contents

Stopping the Engine.....	146
Starting the Engine.....	147
Moving Off.....	148
Shifting Gears.....	149
Triumph Shift Assist (TSA) (if equipped).....	150
Braking.....	151
Anti-lock Braking System (ABS).....	153
Optimized Cornering ABS (OCABS) (if equipped).....	154
Parking.....	155
Considerations for High Speed Operation.....	157

HOW TO RIDE THE MOTORCYCLE

Stopping the Engine

WARNING

Do not stop the engine using the ignition switch or engine start/stop switch while the motorcycle is moving.

Always bring the motorcycle to a stop safely and engage neutral gear prior to stopping the engine.

Stopping the engine by turning off the ignition or engine start/stop switch while the motorcycle is moving can lock the rear wheel, leading to loss of motorcycle control which could result in serious injury or death.

NOTICE

Although the STOP position on the engine start/stop switch stops the engine, it does not turn off all the electrical circuits and may cause difficulty in restarting the engine due to a discharged battery. Ordinarily, only the ignition switch should be used to stop the engine.

Do not leave the ignition switch in the ON position unless the engine is running as this may cause damage to electrical components and will discharge the battery.

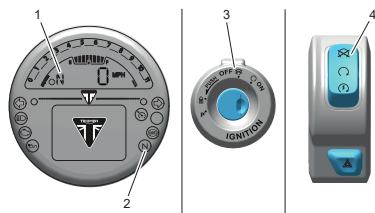

1. Neutral indicator
2. Neutral indicator light
3. OFF position on the ignition switch
4. STOP position on the engine start/stop switch

- ▼ Close the throttle completely.
- ▼ Select neutral.
- ▼ Turn the ignition switch to the OFF position.
- ▼ Select first gear.
- ▼ Support the motorcycle on a firm, level surface with the side stand.
- ▼ Lock the steering.

Starting the Engine

⚠ DANGER

Never start the engine or run the engine in a confined area.

Always operate the motorcycle in the open air or in an area with adequate ventilation.

Exhaust fumes are poisonous and will cause loss of consciousness and death within a short period of time.

NOTICE

Do not operate the starter continuously for more than five seconds as the starter motor will overheat and the battery will become discharged.

Wait 15 seconds between each operation of the starter to allow for cooling and recovery of battery power.

An engine that idles for long periods of time may lead to overheating, which will cause damage to the engine.

NOTICE

The low oil pressure warning light should go out shortly after the engine starts.

If the low oil pressure warning light remains on after starting the engine, stop the engine immediately and investigate the cause.

Running the engine with low oil pressure will cause severe engine damage.

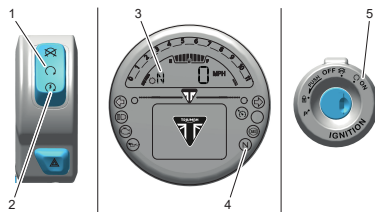

1. **RUN** position on the engine start/stop switch
 2. **START** position on the engine start/stop switch
 3. **Neutral indicator**
 4. **Neutral indicator light**
 5. **ON** position on the ignition switch
- ▼ Check that the engine start/stop switch is in the RUN position.
 - ▼ Make sure the transmission is in neutral.
 - ▼ Pull the clutch lever fully into the handlebar.
 - ▼ Turn the ignition switch to the ON position.

HOW TO RIDE THE MOTORCYCLE

NOTICE

When the ignition is switched on, the instrument warning lights will illuminate and will then go off (except those which normally remain on until the engine starts, see page 58).

A transponder is installed within the key to turn off the engine immobilizer. To make sure the immobilizer functions correctly, always have only one of the ignition keys near the ignition switch. Having two ignition keys near the switch may interrupt the signal between the transponder and the engine immobilizer. In this situation, the engine immobilizer will remain active until one of the ignition keys is removed.

- ▼ Leaving the throttle fully closed, push the starter button until the engine starts.
- ▼ Slowly release the clutch lever.

The motorcycle is equipped with starter lockout switches. The switches prevent the electric starter from operating when a gear is engaged with the side stand down.

If the side stand is extended while the engine is running, and the transmission is not in neutral, the engine will stop regardless of clutch position.

Moving Off

- ▼ Pull in the clutch lever and select first gear.
- ▼ Open the throttle a little and let out the clutch lever slowly.
- ▼ As the clutch starts to engage, open the throttle a little more, allowing enough engine speed to avoid stalling.

Shifting Gears

⚠ WARNING

Take care to avoid opening the throttle too far or too fast in any of the lower gears, as this can lead to the front wheel lifting from the ground (pulling a 'wheelie') and to the rear tire breaking traction (wheel spin).

Always open the throttle cautiously, particularly if you are unfamiliar with the motorcycle.

Pulling a 'wheelie' or loss of traction may lead to loss of motorcycle control, which could result in serious injury or death.

⚠ WARNING

Do not shift to a lower gear at speeds that will cause excessive engine rpm (r/min).

Shifting down should be done such that low engine speeds will be ensured.

Shifting to a lower gear at high speed can lock the rear wheel, leading to loss of motorcycle control, which could result in serious injury or death.

NOTICE

The gear shift mechanism is the 'positive stop' type. This means that, for each movement of the gear shift pedal, you can only select each gear, one after the other, in ascending or descending order.

For models equipped with Triumph Shift Assist (TSA), see page 150.

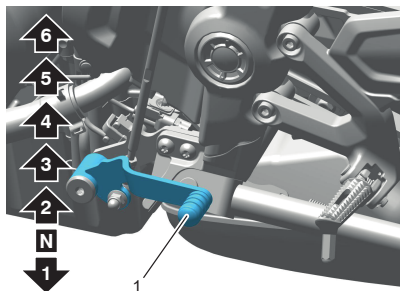

1. Gear shift pedal (Trident 660 shown)

- ▼ Close the throttle while pulling in the clutch lever.
- ▼ Shift into the next higher or lower gear.
- ▼ Open the throttle part way, while releasing the clutch lever.
- ▼ Always use the clutch when shifting gear.

HOW TO RIDE THE MOTORCYCLE

Triumph Shift Assist (TSA) (if equipped)

NOTICE

If there is a TSA system fault when riding, the TSA system will be disabled.

Use the clutch to shift gears in the normal way, otherwise damage to the engine or gear box may occur.

The fault must be checked and rectified by a competent person with the specialist knowledge and technical understanding of motorcycles, such as an authorized Triumph dealer.

NOTICE

Shifting gears must be completed with a quick and forceful pedal movement, making sure that the pedal moves through its full range of travel.

Always take care when shifting gears. After a gear shift, the pedal must be fully released before another gear shift can be made.

Incorrect gear shifts can cause damage to the engine and transmission.

Triumph Shift Assist (TSA) adjusts the engine torque to allow gears to engage, without closure of the throttle twist grip or operation of the clutch.

TSA is not an automatic system for shifting gears. Gears must be selected and shifted in the normal way using the gear pedal as described in Shifting Gears, see page 149.

TSA works for both up shifts and down shifts of gear. The clutch must be used for stopping and pulling away. The clutch must be used when selecting any gear from neutral, and also when selecting neutral from any other gear.

Triumph Shift Assist will not operate if:

- ▼ The clutch is applied.
- ▼ An up shift is attempted by mistake when in top gear.
- ▼ A down shift is attempted by mistake when in 1st gear.
- ▼ An up shift is attempted at very low engine speeds.
- ▼ A down shift is attempted at very high engine speeds.
- ▼ An up shift is attempted during overrun.
- ▼ The vehicle speed limiter (if equipped) is active.
- ▼ Cruise control (if equipped) is active.
- ▼ Traction control is operating.
- ▼ If the previous gear has not fully engaged.
- ▼ The throttle is changed during a shift.

If TSA does not operate, the clutch can be used to shift gears in the normal way.

For more information on enabling and disabling the TSA functionality, see page 83.

Braking

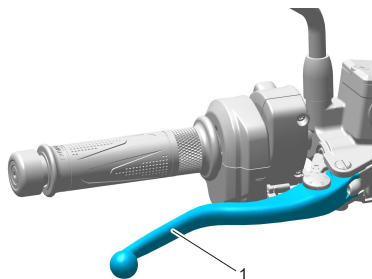

1. Front brake lever (Trident 660 shown)

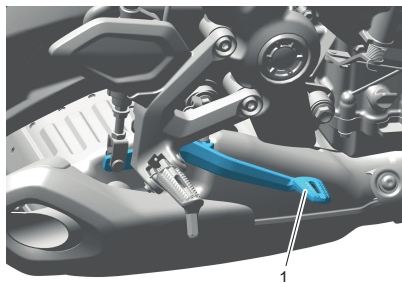

1. Rear brake pedal (Trident 660 shown)

⚠ WARNING

WHEN BRAKING, OBSERVE THE FOLLOWING:

- Close the throttle completely, leaving the clutch engaged to allow the engine to help slow down the motorcycle.
- Shift down one gear at a time such that the transmission is in first gear when the motorcycle comes to a complete stop.
- When stopping, always apply both brakes at the same time. Normally, the front brake should be applied a little more than the rear.
- Shift down or fully disengage the clutch as necessary to keep the engine from stalling.
- Never lock the brakes, as this may cause loss of control of the motorcycle.

Failure to follow the advice above could result in serious injury or death.

⚠ WARNING

For emergency braking, disregard down shifting, and concentrate on applying the front and rear brakes as hard as possible without skidding.

Riders should practice emergency braking in a traffic-free area.

Triumph strongly recommends that all riders take a course of instruction, which includes advice on safe brake operation. Incorrect brake technique may lead to loss of motorcycle control, which could result in serious injury or death.

HOW TO RIDE THE MOTORCYCLE

WARNING

For your safety, always exercise extreme caution when braking, accelerating or turning as any improper action can cause loss of motorcycle control and an accident. Independent use of the front or rear brakes reduces overall braking performance. Extreme braking may cause either wheel to lock, reducing control of the motorcycle and causing an accident (see ABS warnings).

When possible, reduce speed or brake before entering a turn, as closing the throttle or braking in mid-turn may cause wheel slip, leading to loss of control.

When riding in wet or rainy conditions, or on loose surfaces, the ability to maneuver and stop will be reduced. All of your actions should be smooth under these conditions. Sudden acceleration, braking or turning may cause loss of motorcycle control.

Failure to follow the advice above may lead to loss of motorcycle control, which could result in serious injury or death.

WARNING

When descending a long, steep gradient or mountain pass, make use of the engine's braking effect by down shifting and use both front and rear brakes intermittently.

Continuous brake application or use of the rear brake only can overheat the brakes and reduce their effectiveness.

Failure to follow the advice above may lead to loss of motorcycle control, which could result in serious injury or death.

WARNING

Riding with your foot on the brake pedal or your hands on the brake lever may actuate the brake light, giving a false indication to other road users.

It may also overheat the brake, reducing braking effectiveness.

Failure to follow the advice above may lead to loss of motorcycle control, which could result in serious injury or death.

WARNING

Do not coast with the engine switched off, and do not tow the motorcycle.

The transmission is pressure lubricated only when the engine is running.

Inadequate lubrication may cause damage or seizure of the transmission, leading to loss of motorcycle control, which could result in serious injury or death.

Anti-lock Braking System (ABS)

WARNING

The ABS function attempts to maximize the chances of keeping the motorcycle under control when braking. The potentially shorter braking distances ABS allows under certain conditions, are not a substitute for good riding practice.

Always ride within the legal speed limit.

Never ride without due care and attention and always reduce speed in consideration of weather, road and traffic conditions.

Under some circumstances it is possible that a motorcycle equipped with ABS may require a longer stopping distance.

Take care when cornering. If the brakes are applied in a corner, ABS will not be able to counteract the weight and momentum of the motorcycle.

Failure to follow the advice above may lead to loss of motorcycle control, which could result in serious injury or death.

NOTICE

The ABS operation may feel like a harder pedal pressure or a pulsation of the brake lever and pedal.

The ABS is not an integrated braking system and does not control both the front and rear brake at the same time, so this pulsation may be felt in the lever, the pedal or both.

The ABS may be activated by sudden upward or downward changes in the road surface.

ABS Warning Light



When the ignition switch is turned to the ON position, it is normal for the ABS warning light to flash on and off, see page 60. If the ABS warning light is constantly illuminated it indicates that the ABS function is not available because the ABS has a malfunction that requires investigation.

WARNING

If the ABS is not functioning, the brake system will continue to function as a non-ABS equipped brake system. Reduce speed and do not continue to ride for longer than is necessary with the ABS warning light illuminated.

The fault must be checked and rectified by a competent person with the specialist knowledge and technical understanding of motorcycles, such as an authorized Triumph dealer.

Braking too hard will cause the wheels to lock, leading to loss of motorcycle control, which could result in serious injury or death.

WARNING

ABS operates by comparing the relative speed of the front and rear wheels.

Use of non-recommended tires can affect wheel speed and cause the ABS not to operate. Always install recommended tires.

Failure to follow the advice above may lead to loss of motorcycle control, which could result in serious injury or death.

HOW TO RIDE THE MOTORCYCLE

NOTICE

The ABS warning light will illuminate when the rear wheel is driven at high speed for more than 30 seconds when the motorcycle is on a stand. This reaction is normal.

When the ignition is switched off and the motorcycle is restarted, the warning light will illuminate until the motorcycle reaches a speed exceeding 19 mph (30 km/h).

Optimized Cornering ABS (OCABS) (if equipped)

All Models Except Daytona 660

Optimized Cornering ABS (OCABS) is a system designed to help the rider in emergency braking situations. OCABS will also give the rider increased control should the ABS be activated while the motorcycle is leaning in a corner.

A sensor constantly monitors the lean angle of the motorcycle. If the motorcycle is leaning in a corner and the ABS is activated, the system will use the lean angle measurement to apply the ABS in a manner most suitable to help the rider maintain motorcycle control.

The potential increased control that the optimized cornering braking system allows under certain conditions is not a substitute for good riding practice.

WARNING

Always ride within the legal speed limit. Never ride without due care and attention and always reduce speed in consideration of weather, surface and traffic conditions. Take care when cornering.

Under some circumstances it is possible that a motorcycle equipped with OCABS may require a longer stopping distance than an equivalent motorcycle without ABS, or an equivalent motorcycle equipped with ABS but not equipped with OCABS.

If the motorcycle is leaning in a corner and the ABS is activated, the OCABS will use the lean angle measurement from a sensor to apply the ABS to assist the rider to maintain motorcycle control.

The OCABS will not be able to fully counteract the weight and momentum of the motorcycle if braking too hard while cornering. This may lead to loss of motorcycle control, which could result in serious injury or death.

WARNING

If the OCABS is not functioning, the ABS warning light will illuminate and a warning message is shown in the display.

In this situation, the ABS will continue to operate but without the optimized cornering function, provided that there are no other ABS faults.

Do not continue to ride for longer than is necessary with the warning light illuminated. In the event of a fault, contact a competent person with the specialist knowledge and technical understanding of motorcycles, such as an authorized Triumph dealer.

In this situation, braking too hard during cornering may lead to loss of motorcycle control, which could result in serious injury or death.

Parking

WARNING

Gasoline is extremely flammable and can be explosive under certain conditions.

If parking inside a garage or other structure, be sure it is well ventilated and the motorcycle is not close to any source of flame or sparks. This includes any appliance with a pilot light.

Failure to follow the above advice may cause a fire resulting in damage to property, serious injury or death.

CAUTION

The engine and exhaust system will be hot after riding.

DO NOT park where pedestrians and children are likely to touch the motorcycle.

Touching any part of the engine or exhaust system when hot could result in minor to moderate injury.

HOW TO RIDE THE MOTORCYCLE

CAUTION

Take care when parking on soft ground or on a steeply inclined surface.

Parking under these conditions may cause the motorcycle to fall over, which could result in minor to moderate injury.

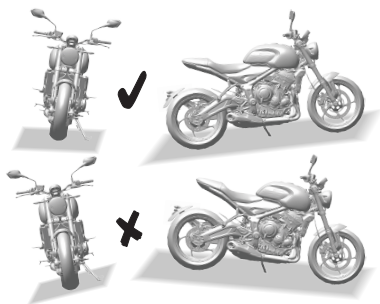

Trident 660 Shown

- ▼ Select neutral and turn the ignition switch to the OFF position.
 - ▼ Select first gear.
 - ▼ Lock the steering to help prevent theft.
- ▼ Always park on a firm, level surface to prevent the motorcycle from falling. This is particularly important when parking off-road.
 - ▼ When parking on a hill, always park facing uphill to prevent the motorcycle from rolling off the stand. Engage first gear to prevent the motorcycle from moving.
 - ▼ On a lateral (sideways) incline, always park such that the incline naturally pushes the motorcycle towards the side stand.
 - ▼ Do not park on a lateral (sideways) incline of greater than 6° and never park facing downhill.
 - ▼ Make sure that the side stand is fully retracted before riding off.
 - ▼ Do not leave the switch in the P (PARK) position for long periods of time as this will discharge the battery.

NOTICE

When parking near traffic at night, or when parking in a location where parking lights are required by law, leave the rear, license plate and position lights on by turning the ignition switch to P (PARK).

Considerations for High Speed Operation

WARNING

This motorcycle should be operated within the legal speed limits for the particular road traveled.

Riding a motorcycle at high speeds can be dangerous since the time available to react to a hazard is greatly reduced at high speeds.

Always reduce speed in potentially hazardous driving conditions, such as bad weather or heavy traffic.

Failure to follow the advice above may lead to loss of motorcycle control, which could result in serious injury or death.

WARNING

Only operate this motorcycle at high speed in closed-course, on-road competition or on closed-course racetracks.

High speed operation should only then be attempted by riders who have been instructed in the techniques necessary for high speed riding and are familiar with the motorcycle's characteristics in all conditions.

High speed operation in any other circumstances is dangerous and may lead to loss of motorcycle control, which could result in serious injury or death.

WARNING

The handling characteristics of a motorcycle at high speed may vary from those you are familiar with at legal road speeds.

Do not attempt high speed operation unless you have received sufficient training and have the required skills.

Failure to follow the advice above may lead to loss of motorcycle control, which could result in serious injury or death.

WARNING

The items listed below are extremely important and must never be neglected.

A problem, which may not be noticed at normal operating speeds, may be greatly exaggerated at high speeds.

Check the items listed below before any high speed operation.

Failure to follow the advice above may lead to loss of motorcycle control, which could result in serious injury or death.

General

Make sure that the motorcycle has been maintained according to the scheduled maintenance chart.

Brakes

Check that the front and rear brakes are functioning correctly.

HOW TO RIDE THE MOTORCYCLE

Coolant

Check that the coolant level is at the upper level line in the expansion tank. Always check the level with the engine cold.

Electrical Equipment

Make sure that all electrical equipment such as the headlight, rear/brake light, turn signals and horn all work correctly.

Engine Oil

Check that the engine oil level is correct. Make sure that the correct grade and type of oil is used when topping off.

Drive Chain

Make sure that the drive chain is correctly adjusted and lubricated. Inspect the chain for wear and damage.

Fuel

NOTICE

In many countries, the exhaust system for this model is equipped with a catalytic converter to help reduce exhaust emission levels.

Use of leaded fuel will damage the catalytic converter. In addition, the catalytic converter can be permanently damaged if the motorcycle is allowed to run out of fuel or if the fuel level is allowed to get very low.

Always make sure you have adequate fuel for your trip.

Have sufficient fuel for the increased fuel consumption that will result from high speed operation.

Luggage

Make sure that any luggage containers are closed, locked and securely installed on the motorcycle.

Miscellaneous

Visually check that all fasteners are tight.

Steering

Check that the handlebar turns smoothly without excessive free play or tight spots. Make sure that the control cables do not restrict the steering in any way.

Tires

High speed operation is hard on tires, and tires that are in good condition are crucial to riding safely. Examine their overall condition, inflate to the correct pressure (when the tires are cold), and check the wheel balance. Securely install the valve caps after checking tire pressures. Observe the information given in the maintenance and specification sections on tire checking and tire safety.

The addition of accessories and carrying of additional weight can affect the motorcycle's handling characteristics, causing changes in stability and necessitating a reduction in speed. The following information has been prepared as a guide to the potential hazards of adding accessories to a motorcycle and carrying passengers and additional loads.

Accessories

WARNING

Do not install accessories or carry luggage that impairs the control of the motorcycle.

Make sure that you have not adversely affected any lighting component, road clearance, banking capability (i.e. lean angle), control operation, wheel travel, front fork movement, visibility in any direction, or any other aspect of the motorcycle's operation.

Failure to follow the advice above may lead to loss of motorcycle control, which could result in serious injury or death.

WARNING

Install only genuine Triumph accessories to the correct Triumph motorcycle model.

Always check the Triumph Installation Instruction associated with the genuine Triumph accessory. Make sure the Triumph motorcycle model that the Triumph accessory is to be installed on, is listed as approved for the genuine Triumph accessory. For all Triumph Installation Instructions, see www.triumphinstructions.com.

Never install genuine Triumph accessories to a Triumph motorcycle model that is not listed in the associated Triumph Installation Instruction, as this may affect handling, stability or other aspects of the motorcycle's operation that may lead to loss of motorcycle control, which could result in serious injury or death.

ACCESSORIES, LOADING AND PASSENGERS

WARNING

Owners should be aware that the only approved parts, accessories and conversions for any Triumph motorcycle are those that carry official Triumph approval.

We recommend accessories and conversions be completed by a competent person with the specialist knowledge and technical understanding of motorcycles, such as an authorized Triumph dealer.

In particular, it is extremely hazardous to install or replace parts or accessories whose installation requires the dismantling of, or addition to, either the electrical or fuel systems. Any such modification could cause a safety hazard.

The installation of any non-approved parts, accessories or conversions may affect the handling, stability or other aspects of the motorcycle's operation, leading to loss of motorcycle control, which could result in serious injury or death.

Triumph does not accept any liability whatsoever for defects caused by the installation of non-approved parts, accessories or conversions.

Triumph does not accept any liability whatsoever for defects caused by the incorrect installation of approved parts, accessories or conversions.

WARNING

Never ride an accessory equipped motorcycle, or a motorcycle carrying a payload of any kind, at speeds above 80 mph (130 km/h). In either/both of these conditions, speeds in excess of 80 mph (130 km/h) should not be attempted, even where the legal speed limit permits this.

The presence of accessories and/or payload will cause changes in the stability and handling of the motorcycle.

Failure to allow for changes in motorcycle stability may lead to loss of motorcycle control. When riding at high speed, always be aware that various motorcycle configuration and environmental factors can adversely affect the stability of your motorcycle. For example:

- Incorrectly balanced loads on both sides of the motorcycle
- Incorrectly adjusted front and rear suspension settings
- Incorrectly adjusted tire pressures
- Excessively or unevenly worn tires
- Side winds and turbulence from other vehicles
- Loose clothing.

Remember that the 80 mph (130 km/h) absolute limit will be reduced by the installation of non-approved accessories, incorrect loading, worn tires, overall motorcycle condition and poor road or weather conditions.

Failure to follow the advice above may lead to loss of motorcycle control, which could result in serious injury or death.

Loading

WARNING

Never attempt to store any items between the frame and the fuel tank. This may restrict the steering aspect of the motorcycle.

Weight attached to the handlebar or front fork will increase the mass of the steering assembly. This may affect the handling, stability or other aspects of the motorcycle operation.

Failure to follow the advice above may lead to loss of motorcycle control, which could result in serious injury or death.

WARNING

The maximum safe load for each pannier is stated on a label inside the pannier and must not be exceeded.

Exceeding this loading limit may affect the handling, stability or other aspects of the motorcycle operation.

Failure to follow the advice above may lead to loss of motorcycle control, which could result in serious injury or death.

WARNING

Do not use the passenger seat to carry any objects.

Carrying objects on the passenger seat may adversely affect the motorcycle stability.

Failure to follow the advice above may lead to loss of motorcycle control, which could result in serious injury or death.

WARNING

Do not carry liquids in containers on your motorcycle.

Liquids are not stable and will adversely affect the motorcycle stability.

Failure to follow the advice above may lead to loss of motorcycle control, which could result in serious injury or death.

ACCESSORIES, LOADING AND PASSENGERS

WARNING

Always make sure that any loads carried are evenly distributed on both sides of the motorcycle. Make sure that the load is correctly secured so that it will not move around while the motorcycle is in motion.

Where two panniers are equipped, evenly distribute the load within each pannier.

Pack heavy items at the bottom and on the inboard side of the pannier.

Always check the load security regularly (though not while the motorcycle is in motion) and make sure that the load does not extend beyond the rear of the motorcycle.

Never exceed the maximum vehicle loading weight as specified in the Specifications section.

This maximum loading weight is made up from the combined weight of the rider, passenger, any accessories installed and any load carried.

For models that have adjustable suspension settings, make sure that front and rear spring preload and damping settings are suitable for the loading condition of the motorcycle. Note the maximum permissible payload for the panniers is stated on a label inside the pannier.

Failure to follow the advice above may lead to loss of motorcycle control, which could result in serious injury or death.

Passengers

WARNING

This motorcycle is designed for use as a two-wheeled vehicle capable of carrying a rider and up to one passenger (subject to a passenger seat and footrests being installed).

The total weight of the rider, and any passenger, accessories and luggage must not exceed the maximum load limit as specified in the Specifications section.

Failure to follow the advice above may lead to loss of motorcycle control, which could result in serious injury or death.

WARNING

When carrying a passenger, the rider must make allowances for the handling and braking characteristics of the motorcycle.

The rider should not attempt to carry a passenger unless familiar and comfortable with the changes in these characteristics.

Failure to follow the advice above may lead to loss of motorcycle control, which could result in serious injury or death.

WARNING

Do not carry a passenger unless they are tall enough to reach the footrests provided.

A passenger who is not tall enough to reach the footrests, will be unable to sit securely on the motorcycle and may cause instability.

Failure to follow the advice above may lead to loss of motorcycle control, which could result in serious injury or death.

WARNING

Do not carry animals on your motorcycle.

An animal could make sudden and unpredictable movements, which may affect the handling, stability or other aspects of the motorcycle operation.

Failure to follow the advice above may lead to loss of motorcycle control, which could result in serious injury or death.

WARNING

Your passenger should be instructed that they can cause loss of motorcycle control by making sudden movements or by adopting an incorrect seated position.

The rider should instruct the passenger as follows:

- It is important that the passenger sits still while the motorcycle is in motion and does not interfere with the operation of the motorcycle.
- To keep their feet on the passenger footrests and to firmly hold onto either the seat strap or grab rails (if equipped) or the rider's waist or hips.
- Advise the passenger to lean with the rider when traveling around corners and not to lean unless the rider does so.

Failure to follow the advice above may lead to loss of motorcycle control, which could result in serious injury or death.

This page intentionally left blank

Table of Contents

Scheduled Maintenance	167
Disposal of Used Fluids	169
Scheduled Maintenance Table - Trident 660, Trident 660 - Triple Tribute, Trident 800, Tiger Sport 660, Tiger Sport 800 and Tiger Sport 800 Tour	170
Scheduled Maintenance Table - Daytona 660	172
Engine Oil	174
Belly Pan - Removal	174
Belly Pan - Installation	175
Engine Oil Level Inspection	176
Engine Oil and Oil Filter Change	178
Engine Oil Specification and Grade (10W/40 and 10W/50)	180
Cooling System	181
Coolant Level Inspection	182
Coolant Level Adjustment	183
Coolant Change	184
Radiator and Hoses	185
Throttle Control	185
Throttle Inspection	185
Clutch	186
Clutch Inspection	186
Clutch Adjustment	187
Drive Chain	188
Drive Chain Lubrication	188
Drive Chain Free Movement Inspection	189
Drive Chain Free Movement Adjustment	190
Drive Chain and Sprocket Wear Inspection	191
Final Drive Chain Guard - Removal	193
Final Drive Chain Guard - Installation	194
Brakes	195
Breaking-in New Brake Discs and Pads	195
Brake Pad Wear Compensation	195
Front Brake Wear Inspection	196
Rear Brake Wear Inspection	197
Disc Brake Fluid	198
Front Brake Fluid Level Inspection and Adjustment	199
Rear Brake Fluid Level Inspection and Adjustment	200
Brake Light Switches	201

MAINTENANCE AND ADJUSTMENT

- Mirrors..... 201
 - Mirror Adjustment..... 203
- Steering/Wheel Bearings..... 204
 - Steering Bearings Inspection 204
 - Wheel Bearings Inspection 205
- Suspension..... 206
 - Front Fork Inspection 207
 - Suspension Settings..... 208
 - Front Suspension Rebound Damping Adjustment 211
 - Front Suspension Compression Damping Adjustment 212
 - Rear Suspension Spring Preload Adjustment 213
 - Rear Suspension Rebound Damping Adjustment 214
- Bank Angle Indicators 215
- Tires..... 216
 - Tire Inflation Pressures 217
 - Tire Pressure Monitoring System (TPMS) (if equipped) 217
 - Tire Wear 218
 - Minimum Recommended Tread Depth 218
 - Tire Replacement..... 218
- Battery..... 221
 - Battery - Removal..... 222
 - Battery Disposal..... 224
 - Battery Maintenance..... 224
 - Battery Discharge..... 224
 - Battery Discharge During Storage and Infrequent Use of the Motorcycle 225
 - Battery Charging 225
 - Battery - Installation 226
- Fuses..... 229
 - Fuse Identification..... 232
- Lights..... 237
 - Headlight(s)..... 237
 - Brake/Tail Light..... 240
 - Turn Signal Lights..... 240
 - License Plate Light 240

Scheduled Maintenance

WARNING

Triumph Motorcycles cannot accept any responsibility for damage or injury resulting from incorrect maintenance or improper adjustment.

Scheduled maintenance must be carried out by a competent person with the specialist knowledge and technical understanding of motorcycles, such as an authorized Triumph dealer.

Incorrect or neglected maintenance may lead to a dangerous riding condition, leading to loss of motorcycle control, which could result in serious injury or death.

WARNING

All maintenance is vitally important and must not be neglected. Incorrect maintenance or adjustment may cause one or more parts of the motorcycle to malfunction.

Weather, terrain and geographical location affect maintenance. The maintenance schedule should be adjusted to match the particular environment in which the motorcycle is used and the demands of the individual owner.

Special tools, knowledge and training are required in order to correctly carry out the maintenance items listed in the scheduled maintenance chart. An authorized Triumph dealer will have the necessary knowledge, equipment, and skills to maintain your Triumph motorcycle correctly.

Scheduled maintenance must be carried out by a competent person with the specialist knowledge and technical understanding of motorcycles, such as an authorized Triumph dealer.

Incorrect or neglected maintenance may lead to a dangerous riding condition, leading to loss of motorcycle control, which could result in serious injury or death.

MAINTENANCE AND ADJUSTMENT

To maintain the motorcycle in a safe and reliable condition, the maintenance and adjustments outlined in this section must be carried out as specified in the schedule of daily checks, and also in line with the scheduled maintenance chart. The information that follows describes the procedures to follow when carrying out the daily checks and some simple maintenance and adjustment items.

Scheduled maintenance may be carried out in three ways; annual maintenance, mileage based maintenance or a combination of both, depending on the mileage the motorcycle travels each year.

- ▼ Motorcycles traveling less than 10,000 miles (16,000 km) per year must be maintained annually. In addition to this, mileage based items require maintenance at their specified intervals, as the motorcycle reaches this mileage.
- ▼ Motorcycles traveling approximately 10,000 miles (16,000 km) per year must have the annual maintenance and the specified mileage based items carried out together.
- ▼ Motorcycles traveling more than 10,000 miles (16,000 km) per year must have the mileage based items maintained as the motorcycle reaches the specified mileage. In addition to this, annual based items will require maintenance at their specified annual intervals.

In all cases, maintenance must be carried out at or before the specified maintenance intervals shown. For advice on which maintenance schedule is most suitable for your motorcycle, contact a competent person with the specialist knowledge and technical understanding of motorcycles, such as an authorized Triumph dealer.

Triumph Motorcycles cannot accept any responsibility for damage or injury resulting from incorrect maintenance or improper adjustment.

Service Symbol/General Warning Symbol



The service symbol will illuminate for five seconds after the motorcycle start up sequence as a reminder that a service is due in approximately 60 miles (100 km). The service symbol will illuminate permanently when the mileage is reached, it will remain permanently illuminated until the service interval is reset. We recommend the service interval is reset by a competent person with the specialist knowledge and technical understanding of motorcycles, such as an authorized Triumph dealer.



The general warning symbol will flash if an ABS or engine management fault has occurred and the ABS and/or MIL warning lights are illuminated. The fault must be checked and rectified by a competent person with the specialist knowledge and technical understanding of motorcycles, such as an authorized Triumph dealer.

Disposal of Used Fluids

To protect the environment, do not pour the following on the ground, down sewers, drains or into groundwater sources:

- ▼ Engine oil
- ▼ Coolant
- ▼ Fuel
- ▼ Clutch and brake fluid
- ▼ Front fork oil.

Do not place used oil filters in with the general waste.

If in doubt for the disposal of the above, contact your local authority.

NOTICE

Items marked * in the Scheduled Maintenance Table are subject to additional labor charge, above the cost and time allowance for the basic service, which includes time to check only.

MAINTENANCE AND ADJUSTMENT

Scheduled Maintenance Table - Trident 660, Trident 660 - Triple Tribute, Trident 800, Tiger Sport 660, Tiger Sport 800 and Tiger Sport 800 Tour

Operation description	Odometer Reading in Miles (km) or Time Period, whichever comes first					
		First Service	Annual Service	Mileage Based Service		
	Daily	600 Mile (1,000 Km) or 6 Month Service	Year	10,000 and 30,000 Mile (16,000 and 48,000 Km) Service	20,000 Mile (32,000 Km) Service	40,000 Mile (64,000 Km) Service
Lubrication						
Engine and oil cooler - check for leaks	•	•	•	•	•	•
Engine oil level - check and adjust	•					
Engine oil - replace		•	•	•	•	•
Engine oil filter - replace		•	•	•	•	•
Fuel System and Engine Management						
Fuel system - check for leaks	•	•	•	•	•	•
Air filter - replace (replace more often if consistently riding in wet or dusty conditions)				•	•	•
Airbox drain tube(s) - drain/clean (if equipped)				•	•	•
MAP sensor drain hose - draining				•	•	•
Spark plugs - replace					•	•
Cooling System						
Cooling system - check for leaks	•	•	•	•	•	•
Coolant level - check/adjust	•	•	•	•	•	•
Cooling system - check coolant hoses for chafing, cracks, pinching or damage. Replace if necessary*		•	•	•	•	•
Coolant - replace - every 4 years, regardless of mileage*		Every four years, regardless of mileage				
Engine						
Clutch - check operation	•	•	•	•	•	•
Clutch cable - check function and adjust/replace as necessary (models equipped with a cable clutch only)*		•	•	•	•	•
Clutch lever pivot - clean/grease			•	•	•	•
Valve clearances - check/adjust*					•	•
Camshaft timing - check/adjust*					•	•
Wheels and Tires						
Wheels - inspect for damage	•	•	•	•	•	•
Tire wear/tire damage - check	•	•	•	•	•	•
Tire pressures - check/adjust	•	•	•	•	•	•
Wheel bearings - check for wear/smooth operation					•	•

Operation description	Odometer Reading in Miles (km) or Time Period, whichever comes first					
		First Service	Annual Service	Mileage Based Service		
	Daily	600 Mile (1,000 Km) or 6 Month Service	Year	10,000 and 30,000 Mile (16,000 and 48,000 Km) Service	20,000 Mile (32,000 Km) Service	40,000 Mile (64,000 Km) Service
Steering and Suspension						
Steering - check for free operation	*	*	*	*	*	*
Front and rear suspension - check for damage/leaks/smooth operation	*	*	*	*	*	*
Headstock bearings - check/adjust - except first service					*	*
Rear suspension unit and linkage - lubricate (single rear suspension unit models only)					*	*
Fork oil - replace						*
Swinging arm spindle - lubricate						*
Brakes						
Brake system - check operation	*	*	*	*	*	*
Brake pads - check wear levels*	*	*	*	*	*	*
Brake fluid levels - check	*	*	*	*	*	*
Brake fluid - replace - every 2 years, regardless of mileage*	Every two years, regardless of mileage					
Final Drive						
Drive chain slack - check/adjust	*	*	*	*	*	*
Drive chain - wear check*		*	*	*	*	*
Drive chain - lubricate	Every 200 miles (300 km)					
Drive chain rubbing strip - check for wear, cracks or damage*		*	*	*	*	*
Electrical						
Lights, instruments and electrical systems - check/adjust	*	*	*	*	*	*
General						
Bank angle indicators - check for wear*	*	*	*	*	*	*
Center and/or side stand - check for wear/smooth operation	*	*	*	*	*	*
Instruments and engine ECM - check for latest calibration download using the Triumph diagnostic tool		*	*	*	*	*
Autoscan - carry out a full Autoscan using the Triumph diagnostic tool (print a customer copy)		*	*	*	*	*
Carry out all outstanding Service Bulletin and warranty work		*	*	*	*	*
Carry out road test		*	*	*	*	*
Complete the service record book and reset the service indicator (if equipped)		*	*	*	*	*
Center stand pivots - clean/grease				*	*	*

MAINTENANCE AND ADJUSTMENT

Scheduled Maintenance Table - Daytona 660

Operation description	Odometer Reading in Miles (km) or Time Period, whichever comes first					
		First Service	Annual Service	Mileage Based Service		
	Daily	600 Mile (1,000 Km) or 6 Month Service	Year	10,000 and 30,000 Mile (16,000 and 48,000 Km) Service	20,000 Mile (32,000 Km) Service	40,000 Mile (64,000 Km) Service
Lubrication						
Engine and oil cooler - check for leaks	•	•	•	•	•	•
Engine oil level - check and adjust	•					
Engine oil - replace		•	•	•	•	•
Engine oil filter - replace		•	•	•	•	•
Fuel System and Engine Management						
Fuel system - check for leaks	•	•	•	•	•	•
Air filter - replace (replace more often if consistently riding in wet or dusty conditions)				•	•	•
Spark plugs - replace					•	•
Cooling System						
Cooling system - check for leaks	•	•	•	•	•	•
Coolant level - check/adjust	•	•	•	•	•	•
Cooling system - check coolant hoses for chafing, cracks, pinching or damage. Replace if necessary*		•	•		•	•
Coolant - replace - every 4 years, regardless of mileage*		Every four years, regardless of mileage				
Engine						
Clutch - check operation	•	•	•	•	•	•
Clutch cable - check function and adjust/replace as necessary (models equipped with a cable clutch only)*		•	•	•	•	•
Clutch lever pivot - clean/grease			•	•	•	•
Valve clearances - check/adjust*					•	•
Camshaft drive chain - replace					•	•
Camshaft timing - check/adjust*					•	•
Wheels and Tires						
Wheels - inspect for damage	•	•	•		•	•
Tire wear/tire damage - check	•	•	•	•	•	•
Tire pressures - check/adjust	•	•	•	•	•	•
Wheel bearings - check for wear/smooth operation					•	•

Operation description	Odometer Reading in Miles (km) or Time Period, whichever comes first					
		First Service	Annual Service	Mileage Based Service		
	Daily	600 Mile (1,000 Km) or 6 Month Service	Year	10,000 and 30,000 Mile (16,000 and 48,000 Km) Service	20,000 Mile (32,000 Km) Service	40,000 Mile (64,000 Km) Service
Steering and Suspension						
Steering - check for free operation	•	•	•	•	•	•
Front and rear suspension - check for damage/leaks/smooth operation	•	•	•	•	•	•
Headstock bearings - check/adjust - except first service					•	•
Rear suspension unit and linkage - lubricate (single rear suspension unit models only)					•	•
Fork oil - replace						•
Swinging arm spindle - lubricate						•
Brakes						
Brake system - check operation	•	•	•	•	•	•
Brake pads - check wear levels*	•	•	•	•	•	•
Brake fluid levels - check	•	•	•	•	•	•
Brake fluid - replace - every 2 years, regardless of mileage*	Every two years, regardless of mileage					
Final Drive						
Drive chain slack - check/adjust	•	•	•	•	•	•
Drive chain - wear check*		•	•	•	•	•
Drive chain - lubricate	Every 200 miles (300 km)					
Drive chain rubbing strip - check for wear, cracks or damage*		•	•	•	•	•
Electrical						
Lights, instruments and electrical systems - check/adjust	•	•	•	•	•	•
General						
Bank angle indicators - check for wear*	•	•	•	•	•	•
Center and/or side stand - check for wear/smooth operation	•	•	•	•	•	•
Instruments and engine ECM - check for latest calibration download using the Triumph diagnostic tool		•	•	•	•	•
Autoscan - carry out a full Autoscan using the Triumph diagnostic tool (print a customer copy)		•	•	•	•	•
Carry out all outstanding Service Bulletin and warranty work		•	•	•	•	•
Carry out road test		•	•	•	•	•
Complete the service record book and reset the service indicator (if equipped)		•	•	•	•	•

MAINTENANCE AND ADJUSTMENT

Engine Oil



⚠ WARNING

Make sure that the engine oil level is correct and the oil is changed in accordance with the scheduled maintenance requirements.

Motorcycle operation with insufficient, deteriorated, or contaminated engine oil will cause accelerated engine wear and may result in engine or transmission seizure.

Seizure of the engine or transmission may lead to sudden loss of motorcycle control, which could result in serious injury or death.

In order for the engine, transmission, and clutch to function correctly, maintain the engine oil at the correct level, and change the engine oil and oil filter in accordance with scheduled maintenance requirements.

Belly Pan - Removal

⚠ WARNING

Make sure that the motorcycle is stabilized and adequately supported.

Do not support the motorcycle on any ancillary component, the exhaust system or any other non-structural parts of the motorcycle frame.

A correctly supported motorcycle will help prevent it from falling.

Failure to follow the advice above could result in serious injury or death.

Trident 660 and Trident 660 - Triple Tribute Only

NOTICE

Only the left hand belly pan needs to be removed to change the engine oil and oil filter.

- ▼ Remove the two fasteners from the bracket securing the belly pan to the sump and remove the belly pan.

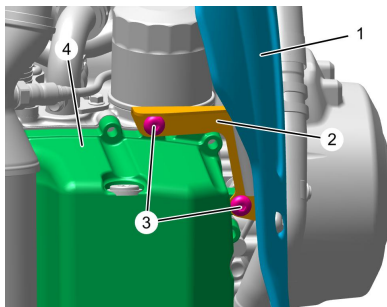

1. Belly pan (viewed from below)
2. Bracket
3. Fasteners
4. Sump

Tiger Sport 800, Tiger Sport 800 Tour and Trident 800 Only

- ▼ Remove the two fasteners that attach the belly pan assembly to the engine brackets. Discard the fasteners.
- ▼ Lower the rear of the belly pan sufficiently to clear the brackets.
- ▼ Move the belly pan forwards to loosen it from the left and right mounting grommets.

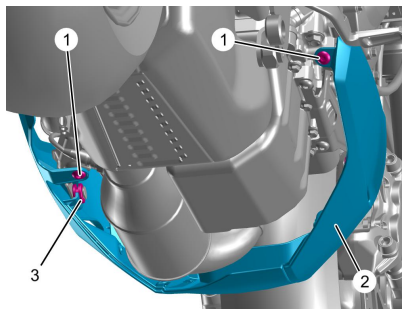

1. Fasteners
2. Belly pan panel
3. Mounting grommet (left side shown)

Belly Pan - Installation

⚠ WARNING

Make sure that the motorcycle is stabilized and adequately supported.

Do not support the motorcycle on any ancillary component, the exhaust system or any other non-structural parts of the motorcycle frame.

A correctly supported motorcycle will help prevent it from falling.

Failure to follow the advice above could result in serious injury or death.

Trident 660 and Trident 660 - Triple Tribute Only

- ▼ Mount the two fasteners to the bracket and tighten to 53 lbf in (6 Nm).

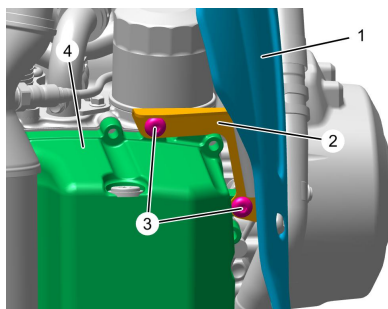

1. Belly pan (viewed from below)
2. Bracket
3. Fasteners
4. Sump

MAINTENANCE AND ADJUSTMENT

Tiger Sport 800, Tiger Sport 800 Tour and Trident 800 Only

- ▼ Engage the belly pan assembly onto the left and right mounting grommets.
- ▼ Align the belly pan assembly with the fastener brackets.

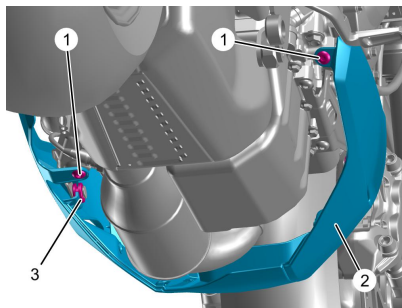

1. Fasteners
2. Belly pan panel
3. Mounting grommet (left side shown)

NOTICE

When you install the fasteners, make sure that the shoulder is fully located into the belly pan molding.

- ▼ Install two new fasteners and tighten to 27 lbf in (3 Nm).

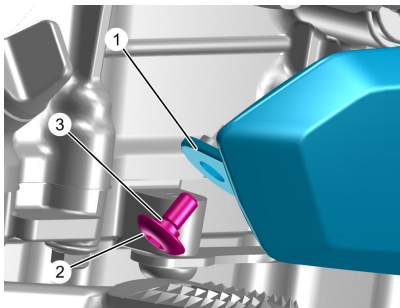

1. Belly Pan molding
2. Fastener
3. Fastener shoulder

Engine Oil Level Inspection

⚠ DANGER

Never start the engine or run the engine in a confined area.

Always operate the motorcycle in the open air or in an area with adequate ventilation.

Exhaust fumes are poisonous and will cause loss of consciousness and death within a short period of time.

⚠ CAUTION

If the engine has recently been running, the exhaust components may be hot to the touch.

To avoid skin damage, always allow the hot parts to cool before touching the exhaust system.

Contact with the hot components may cause minor to moderate injury to exposed skin.

NOTICE

Make sure no contamination enters the engine during an engine oil change or top off.

Contamination entering the engine may lead to engine damage.

NOTICE

If the engine oil pressure is too low, the low oil pressure warning light will illuminate.

If the low oil pressure indicator remains on, stop the engine immediately and investigate the situation.

Running the engine with low oil pressure will cause severe engine damage.

NOTICE

An accurate indication of the level of oil in the engine is only shown when the engine is at normal operating temperature, the motorcycle is upright (not on the side stand) and when the dipstick has been fully tightened.

Do not add oil through the dipstick hole in the crankcase.

- ▼ Position the motorcycle on level ground and in an upright position.

- ▼ Start the engine and run at idle for approximately five minutes.
- ▼ Stop the engine and wait for at least three minutes for the oil to settle.
- ▼ Remove the dipstick.
- ▼ The oil level is indicated by lines on the dipstick. When full, the indicated oil level must be level with the upper marking on the dipstick.
- ▼ If the oil level is below the lower marking, remove the filler plug and add oil a little at a time through the filler plug hole in the clutch cover until the correct level is reached.
- ▼ Once the correct level is reached, install and tighten the filler plug.

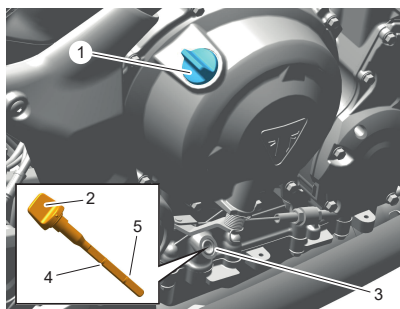

1. Engine oil filler (Trident 660 shown)
2. Dipstick
3. Dipstick location in crankcase
4. Upper marking
5. Lower marking

MAINTENANCE AND ADJUSTMENT

Engine Oil and Oil Filter Change

⚠ WARNING

Always wear suitable protective clothing and avoid skin contact with used engine oil.

Prolonged or repeated contact with engine oil can lead to skin dryness, irritation and dermatitis.

Used engine oil contains harmful contamination that can lead to skin cancer.

Failure to follow the advice above could result in serious injury or death.

⚠ CAUTION

The engine oil may be hot.

Avoid contact with the hot engine oil by wearing suitable protective clothing, gloves and eye protection.

Contact with the hot engine oil may cause minor to moderate injury to exposed skin.

⚠ CAUTION

If the engine has recently been running, the exhaust components may be hot to the touch.

To avoid skin damage, always allow the hot parts to cool before touching the exhaust system.

Contact with the hot components may cause minor to moderate injury to exposed skin.

The engine oil and engine oil filter must be replaced in accordance with scheduled maintenance requirements.

- ▼ For Trident 660, Trident 660 - Triple Tribute, Tiger Sport 800, Tiger Sport 800 Tour and Trident 800 remove the belly pan, see page 174.
- ▼ For Daytona 660 remove the left hand fairing, see page 120.
- ▼ Warm up the engine thoroughly and stop the engine.
- ▼ Position the motorcycle on level ground and in an upright position.
- ▼ Place an oil drain pan beneath the engine.
- ▼ Remove the oil drain plug.
- ▼ Discard the sealing washer.
- ▼ Unscrew and remove the oil filter using Triumph service tool T3880313. Dispose of the old oil filter in an environmentally friendly way.
- ▼ Apply a thin smear of clean engine oil to the sealing ring of the new oil filter.
- ▼ Install the oil filter and tighten to 89 lbf in (10 Nm).
- ▼ After the oil has completely drained out, install a new sealing washer to the drain plug.
- ▼ Install and tighten the drain plug to 18 lbf ft (25 Nm).

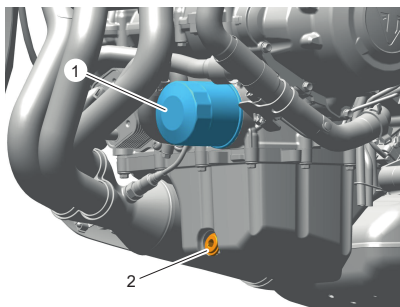

1. Engine oil filter (Trident 660 shown)
2. Engine oil drain plug

- ▼ Using a suitable funnel, fill the engine with a fully or semi-synthetic 10W/40 or 10W/50 motorcycle engine oil that meets specification API SN (or higher) and JASO MA2. Triumph Performance fully synthetic engine oil is recommended.

NOTICE

The engine oil grade specified must be used.

Using the incorrect engine oil grade may result in engine damage.

- ▼ Start the engine and allow it to idle for a minimum of 30 seconds.

NOTICE

Raising the engine speed above idle before the oil reaches all parts of the engine can cause engine damage or seizure.

Only raise engine speed after running the engine for 30 seconds to allow the oil to circulate fully.

- ▼ Make sure that the low oil pressure warning light remains off and the oil pressure message is not shown in the instrument display screen.

NOTICE

If the engine oil pressure is too low, the low oil pressure warning light will illuminate.

If the low oil pressure indicator remains on, stop the engine immediately and investigate the situation.

Running the engine with low oil pressure will cause severe engine damage.

- ▼ Stop the engine and recheck the oil level. Adjust if necessary.
- ▼ For Trident 660, Trident 660 - Triple Tribute, Tiger Sport 800, Tiger Sport 800 Tour and Trident 800 reinstall the belly pan, see page 175.
- ▼ For Daytona 660 reinstall the left hand fairing, see page 123.

MAINTENANCE AND ADJUSTMENT

Engine Oil Specification and Grade (10W/40 and 10W/50)

NOTICE

The engine oil grade specified must be used.

Using the incorrect engine oil grade may result in engine damage.

This Triumph high-performance fuel injected engine is designed to use fully or semi-synthetic 10W/40 or 10W/50 motorcycle engine oil that meets specification API SN (or higher) and JASO MA2. Triumph Performance fully synthetic engine oil is recommended.

Refer to the chart below for the correct oil viscosity (10W/40 or 10W/50) to be used in your riding area.

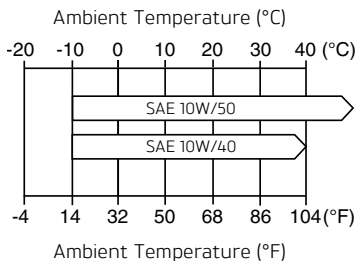

Oil Viscosity Temperature Range

Do not add any chemical additives to the engine oil. The engine oil also lubricates the clutch and any additives could cause the clutch to slip.

Do not use mineral, vegetable, non-detergent oil, castor based oils or any oil not conforming to the required specification. The use of these oils may cause instant, severe engine damage.

Make sure that no foreign matter enters the crankcase during an engine oil change or top off.

Cooling System



NOTICE

The motorcycle is equipped with D2053 coolant, a year-round, Organic Additive Technology (known as OAT) coolant when it leaves the factory. It is colored orange, and contains a 50% solution of monoethylene glycol based antifreeze.

D2053 coolant, as supplied by Triumph, provides freeze protection to -40°F (-40°C).

To ensure efficient engine cooling, check the coolant level each day before riding the motorcycle, and top off the coolant if the level is low.

Corrosion Inhibitors

⚠ WARNING

D2053 OAT coolant contains corrosion inhibitors and antifreeze suitable for aluminum engines and radiators. Always use the coolant in accordance with the instructions of the manufacturer.

Coolant contains toxic chemicals that are harmful to the human body.

Contact with skin or eyes may cause severe irritation. Wear protective gloves, clothing and eye protection when handling coolant.

If coolant is inhaled, remove the person to fresh air and keep comfortable for breathing. In case of doubt or persistent symptoms, seek medical attention.

If coolant gets on your skin, flush with water immediately. Remove contaminated clothing.

If coolant gets in your eyes, flush with water for at least 15 minutes and SEEK MEDICAL ATTENTION IMMEDIATELY.

If coolant is swallowed, rinse the mouth with water and SEEK MEDICAL ATTENTION IMMEDIATELY.

KEEP COOLANT OUT OF THE REACH OF CHILDREN.

Failure to follow the advice above could result in serious injury or death.

NOTICE

D2053 OAT coolant, as supplied by Triumph, is premixed and does not need to be diluted prior to filling or topping off the cooling system.

MAINTENANCE AND ADJUSTMENT

To protect the cooling system from corrosion, the use of corrosion inhibiting chemicals in the coolant is essential.

If coolant containing a corrosion inhibitor is not used, the cooling system will accumulate rust and scale in the water jacket and radiator. This will block the coolant passages, and considerably reduce the efficiency of the cooling system.

Coolants of different types must not be mixed. Mixing coolants of different types will reduce the performance of the coolant and reduce its life. When replacing coolant, it is recommended to thoroughly flush the cooling system with clean water.

Coolant Level Inspection

NOTICE

The coolant level should be checked when the engine is cold (at room or ambient temperature).

- ▼ Position the motorcycle on level ground and in an upright position. The expansion tank can be viewed from the left hand side of the motorcycle, below and towards the front of the fuel tank.

- ▼ Check the coolant level in the expansion tank. The coolant level must be between the MAX and MIN marks.

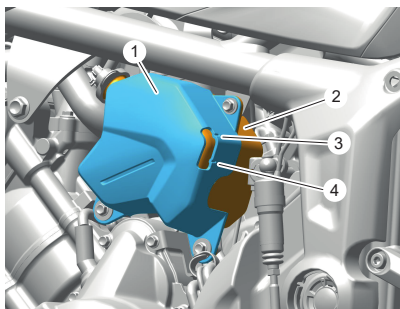

1. Expansion tank cover (Trident 660 shown)
2. Expansion tank
3. MAX mark
4. MIN mark

- ▼ If the coolant is below the minimum level, the coolant level must be adjusted, see page 183.

Coolant Level Adjustment

CAUTION

Do not remove the radiator pressure cap when the engine is hot.

When the engine is hot, the coolant inside the radiator will be hot and also under pressure.

Contact with this hot, pressurized coolant may cause minor to moderate injury to exposed skin.

NOTICE

If hard water is used in the cooling system, it will cause scale accumulation in the engine and radiator and considerably reduce the efficiency of the cooling system.

Reduced cooling system efficiency may cause the engine to overheat and suffer severe damage.

- ▼ Allow the engine to cool.

Daytona 660 Only

- ▼ Remove the deflector fairing as follows.
- ▼ Detach the top of the deflector fairing away from the motorcycle until it is free from the retaining grommet (leaving the grommet in place) and clip.
- ▼ Slide the deflector fairing downwards to detach it from its retaining tang.

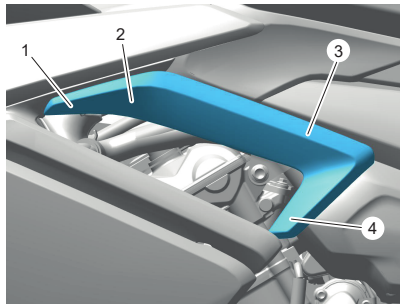

1. Deflector fairing
2. Retaining grommet location
3. Retaining clip location
4. Retaining tang location

MAINTENANCE AND ADJUSTMENT

All Models

- ▼ Remove the expansion tank cap.
- ▼ Add coolant mixture through the filler opening until the level reaches the MAX mark.
- ▼ Install the expansion tank cap.

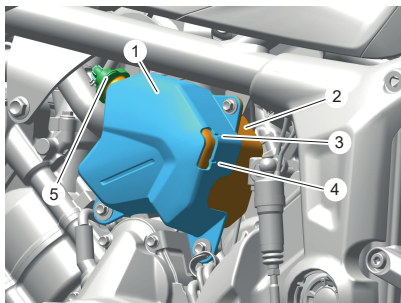

1. Expansion tank cover (Trident 660 shown)
2. Expansion tank
3. MAX mark
4. MIN mark
5. Expansion tank cap

Daytona 660 Only

- ▼ Install the deflector fairing as follows.
- ▼ Position the deflector fairing locating feature onto the retaining tang and press the panel into the retaining grommet and clip.

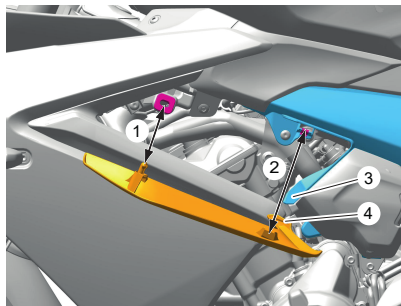

1. Retaining grommet
2. Retaining clip
3. Retaining tang
4. Locating feature

NOTICE

If the coolant level is being checked because the coolant has overheated, also check the level in the radiator and top off if necessary.

In an emergency, distilled water can be added to the cooling system. However, the coolant must then be drained and replenished with D2053 OAT coolant as soon as possible.

Coolant Change

We recommend that the coolant is changed in accordance with scheduled maintenance requirements.

Radiator and Hoses

CAUTION

The fan operates automatically when the engine is running.

Always keep hands and clothing away from the fan.

Contact with the rotating fan could result in minor to moderate injury.

NOTICE

Using high pressure water sprays, such as from a car wash facility or household pressure washer, can damage the radiator fins, cause leaks and impair the radiator's efficiency.

Do not obstruct or deflect airflow through the radiator by installing unauthorized accessories, either in front of the radiator or behind the cooling fan.

Interference with the radiator airflow can cause overheating, potentially resulting in engine damage.

Check the radiator hoses for cracks or deterioration, and tension clips for tightness in accordance with scheduled maintenance requirements. Any defective items must be replaced by a competent person with the specialist knowledge and technical understanding of motorcycles, such as an authorized Triumph dealer.

Check the radiator grille and fins for obstructions by insects, leaves or mud. Clean off any obstructions with a stream of low pressure water.

Throttle Control

WARNING

Always be alert for changes in the 'feel' of the throttle control. Changes can be due to wear in the mechanism, which could lead to a sticking or stuck throttle control.

If any changes are detected, the throttle system must be inspected by a competent person with the specialist knowledge and technical understanding of motorcycles, such as an authorized Triumph dealer.

A sticking or stuck throttle control may lead to loss of motorcycle control, which could result in serious injury or death.

Throttle Inspection

WARNING

Use of the motorcycle with a sticking or damaged throttle control will interfere with the throttle function. The throttle may be difficult to control and performance will be affected.

To avoid continued use of a sticking or damaged throttle control, the throttle system must be inspected by a competent person with the specialist knowledge and technical understanding of motorcycles, such as an authorized Triumph dealer.

Failure to follow the advice above may lead to loss of motorcycle control, which could result in serious injury or death.

MAINTENANCE AND ADJUSTMENT

- ▼ Check that the throttle opens smoothly, without undue force and that it closes quickly under its own return spring force without sticking and without manual intervention.
- ▼ Check that there is 0.04 - 0.08 in (1 - 2 mm) of throttle grip free play when lightly turning the throttle grip back and forth.
- ▼ If a problem is detected or any doubt exists, or if there is an incorrect amount of free play, the throttle system must be inspected by a competent person with the specialist knowledge and technical understanding of motorcycles, such as an authorized Triumph dealer.

Clutch

The motorcycle is equipped with a cable operated clutch.

If the clutch lever has excessive free play, the clutch may not disengage fully. This will cause difficulty in shifting gear and selecting neutral. This may cause the engine to stall and make the motorcycle difficult to control.

Conversely, if the clutch lever has insufficient free play the clutch may not engage fully, causing the clutch to slip, which will reduce performance and cause premature clutch wear.

Clutch lever free play must be checked in accordance with scheduled maintenance requirements.

Clutch Inspection

- ▼ Check that there is 0.08 - 0.12 in (2 - 3 mm) clutch lever free play at the lever.
- ▼ If there is an incorrect amount of free play, adjustments must be made.

Clutch Adjustment

Clutch Lever Adjustment

- ▼ Loosen the lock nut.
- ▼ Turn the adjuster sleeve to give the correct amount of free play.
- ▼ Tighten the lock nut.

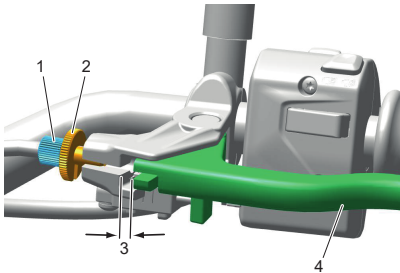

1. Adjuster sleeve (Trident 660 shown)
2. Lock nut (fully loosened position shown)
3. Correct clearance (0.08 - 0.12 in (2 - 3 mm))
4. Clutch lever

NOTICE

If correct adjustment cannot be made using the lever adjuster, use the cable adjuster at the clutch end of the cable.

Clutch Cable Adjustment at the Clutch End

- ▼ Loosen the lock nut at the clutch lever.
- ▼ Turn the adjuster sleeve fully into the clutch lever housing, then turn back two complete turns.
- ▼ Tighten the lock nut at the clutch lever.
- ▼ If the clutch cable is tight, loosen the front lock nut (2) and tighten the rear lock nut (1) to give the correct amount of free play at the clutch lever.
- ▼ If the clutch cable is loose, loosen the rear lock nut (1) and tighten the front lock nut (2) to give the correct amount of free play at the clutch lever.
- ▼ Tighten the adjuster lock nuts to 27 lbf in (3 Nm).

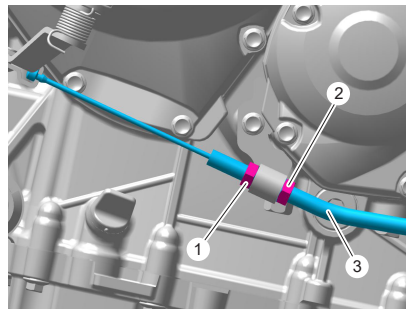

1. Rear adjuster lock nut (Trident 660 shown)
 2. Front adjuster lock nut
 3. Clutch outer cable
- ▼ Check that there is 0.08 - 0.12 in (2 - 3 mm) clutch lever free play at the lever. Adjust at the clutch lever end if required.

Drive Chain



! DANGER

A loose or worn chain, or a chain that breaks or jumps off the sprockets could catch on the engine sprocket or lock the rear wheel.

A chain that snags on the engine sprocket or locks the rear wheel will injure the rider.

Failure to follow the advice above will lead to loss of motorcycle control, which will result in serious injury or death.

For safety and to prevent excessive wear, the drive chain must be checked, adjusted and lubricated in accordance with scheduled maintenance requirements. Checks, adjustments and lubrication must be carried out more frequently for extreme conditions, such as high speed riding, salty or heavily gritted roads.

If the chain is badly worn or incorrectly adjusted (either too loose or too tight), the chain could jump off the sprockets or break. Therefore, we recommend to always replace worn or damaged chains using genuine Triumph parts.

Drive Chain Lubrication

Lubrication is necessary every 200 miles (300 km) and also after riding in wet weather, on wet roads, or any time that the chain appears dry.

- ▼ Use the special drive chain lubricant as recommended in the Specifications section.
- ▼ Apply lubricant to the sides of the rollers then allow the motorcycle to stand unused for at least eight hours (overnight is ideal). This will allow the lubricant to penetrate to the drive chain O-rings etc.
- ▼ Before riding, wipe off any excess lubricant.

NOTICE

Do not use a pressure washer to clean the drive chain as this may cause damage to the drive chain components.

- ▼ If the drive chain is especially dirty, clean first and then apply lubricant as mentioned above.

Drive Chain Free Movement Inspection

⚠ WARNING

Make sure that the motorcycle is stabilized and adequately supported.

Do not support the motorcycle on any ancillary component, the exhaust system or any other non-structural parts of the motorcycle frame.

A correctly supported motorcycle will help prevent it from falling.

Failure to follow the advice above could result in serious injury or death.

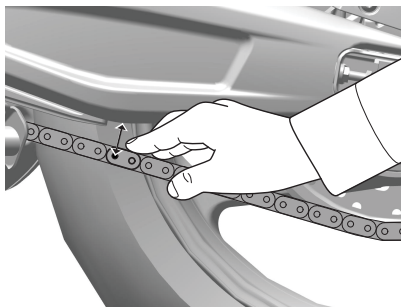

Trident 660 Shown

- ▼ Place the motorcycle on a level surface and hold it in an upright position with no weight on it.
- ▼ Rotate the rear wheel by pushing the motorcycle to find the position where the chain is tightest.
- ▼ Stretch the chain taut by applying pressure on the chain.
- ▼ Measure from the bottom of the swingarm to the center of the chain pin, as shown in the illustration.

NOTICE

The drive chain free play measurement value is different to the drive chain adjustment measurement. Please refer to the correct measurement corresponding to the process being performed.

- ▼ The measurement must be in the range of 1.69 - 1.97 in (43 - 50 mm).

If the measurement is below or exceeds the range, the chain needs to be adjusted.

MAINTENANCE AND ADJUSTMENT

Drive Chain Free Movement Adjustment

⚠ WARNING

When the drive chain adjustment is complete, make sure the wheel spindle and the adjuster lock nuts are tightened to the correct torque.

Operation of the motorcycle with a loose wheel spindle and/or loose adjuster lock nuts may affect the handling and stability.

Failure to follow the advice above may lead to loss of motorcycle control, which could result in serious injury or death.

NOTICE

The drive chain free play measurement value is different to the drive chain adjustment measurement. Please refer to the correct measurement corresponding to the process being performed.

The vertical movement of the drive chain must be in the range of 1.69 - 1.81 in (43 - 46 mm).

If the drive chain free movement measurement is incorrect, adjustments must be made as follows:

- ▼ Loosen the rear wheel spindle nut.
- ▼ Loosen the adjuster bolt lock nut on both the left and right hand drive chain adjuster bolts.

- ▼ Equally turn both the left and right hand adjuster bolts clockwise (A) to increase drive chain free movement and counterclockwise (B) to decrease drive chain free movement.
- ▼ When the correct amount of drive chain free movement has been set, push the wheel into firm contact with the adjusters.
- ▼ Make sure the same adjuster marking is aligned with the spindle adjuster on both sides of the swinging arm.

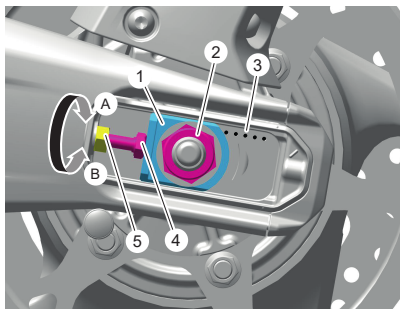

1. Spindle adjuster
2. Rear wheel spindle nut
3. Adjuster markings
4. Adjuster bolt
5. Adjuster bolt lock nut

A. Clockwise direction

B. Counterclockwise direction

- ▼ Tighten both adjuster bolt lock nuts to 12 lbf ft (16 Nm) and the rear wheel spindle nut to 81 lbf ft (110 Nm).
- ▼ Repeat the drive chain adjustment check. Readjust if necessary.
- ▼ Check the rear brake effectiveness. Rectify if necessary.

WARNING

It is dangerous to operate the motorcycle with defective brakes.

If a problem is detected or any doubt exists, the brakes must be inspected by a competent person with the specialist knowledge and technical understanding of motorcycles, such as an authorized Triumph dealer.

Operation of the motorcycle with defective brakes may lead to loss of motorcycle control which could result in serious injury or death.

NOTICE

If the sprockets are found to be worn, always replace the sprockets and drive chain together.

Replacing worn sprockets without also replacing the drive chain will lead to premature wear of the new sprockets.

- ▼ Remove the final drive chain guard, see page 193.

Drive Chain Damage Inspection

WARNING

If the drive chain is found to have damaged rollers, loose pins or stiff links, the drive chain must be replaced.

Do not attempt to loosen any stiff links. The stiff link may have damaged or worn components.

Riding with drive chain stiff links, or loosened stiff links, may result in a broken drive chain or may cause the drive chain to jump off the sprockets, leading to loss of motorcycle control which could result in serious injury or death.

Drive Chain and Sprocket Wear Inspection

WARNING

Replacement drive chains must be installed by a competent person with the specialist knowledge and technical understanding of motorcycles, such as an authorized Triumph dealer.

We recommend to always replace worn or damaged chains using genuine Triumph parts.

Incorrectly installed drive chains may result in a broken drive chain or may cause the drive chain to jump off the sprockets, leading to loss of motorcycle control which could result in serious injury or death.

MAINTENANCE AND ADJUSTMENT

- ▼ Rotate the rear wheel and inspect the drive chain for damaged rollers, loose pins and stiff links.

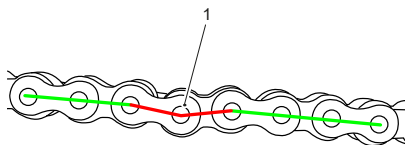

1. Stiff link

- ▼ If the drive chain has any damaged rollers, loose pins or stiff links, the drive chain must be replaced by a competent person with the specialist knowledge and technical understanding of motorcycles, such as an authorized Triumph dealer.

Drive Chain Wear Inspection

- ▼ Stretch the drive chain taut by hanging a 20 - 40 lb (10 - 20 kg) weight on the drive chain.
- ▼ Measure the length of 20 links on the straight part of the drive chain from pin center of the 1st pin to the pin center of the 21st pin. Since the drive chain may wear unevenly, take measurements in several places.

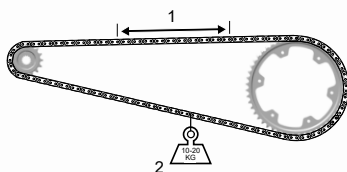

1. Measure across 20 links

2. Weight

- ▼ If the length exceeds the maximum service limit, the drive chain must be replaced. Refer to the Specifications section for the maximum service limit.

Sprockets Wear Inspection

NOTICE

The illustration shows wear on sprockets mounted on the left hand side of the motorcycle.

For sprockets mounted on the right hand side of the motorcycle, the wear is on the opposite side of the tooth.

- ▼ Rotate the rear wheel and inspect the sprockets for unevenly or excessively worn or damaged teeth.

Worn Tooth (Engine Sprocket) Worn Tooth (Rear Sprocket)



(Sprocket wear exaggerated for illustrative purposes)

cool

- ▼ If there is any wear or damage, the drive chain and the sprockets must be replaced by a competent person with the specialist knowledge and technical understanding of motorcycles, such as an authorized Triumph dealer.
- ▼ Reinstall the final drive chain guard, see page 194.

Final Drive Chain Guard - Removal

WARNING

Make sure that the motorcycle is stabilized and adequately supported.

Do not support the motorcycle on any ancillary component, the exhaust system or any other non-structural parts of the motorcycle frame.

A correctly supported motorcycle will help prevent it from falling.

Failure to follow the advice above could result in serious injury or death.

- ▼ Remove the two fasteners securing the rear hugger and chain guard to the swingarm.
- ▼ Maneuver the rear hugger and chain guard rearwards to detach the two locating slots from the retaining grommets.
- ▼ Detach the rear hugger and chain guard from the rear suspension linkage guard and remove the rear hugger and chain guard.

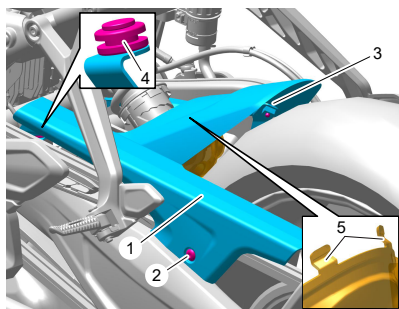

1. Rear hugger and chain guard (Trident 660 shown)
2. Fastener (left hand side)
3. Fastener (right hand side)
4. Retaining grommets (left hand side shown)
5. Retaining tangs (on the linkage guard)

MAINTENANCE AND ADJUSTMENT

Final Drive Chain Guard - Installation

⚠ WARNING

Make sure that the motorcycle is stabilized and adequately supported.

Do not support the motorcycle on any ancillary component, the exhaust system or any other non-structural parts of the motorcycle frame.

A correctly supported motorcycle will help prevent it from falling.

Failure to follow the advice above could result in serious injury or death.

- ▼ Attach the hugger and chain guard to the rear suspension linkage guard.
- ▼ Make sure the two retaining tangs on the rear suspension linkage guard are in the locating holes on the rear hugger and chain guard, as shown in the illustration below (items removed for clarity).

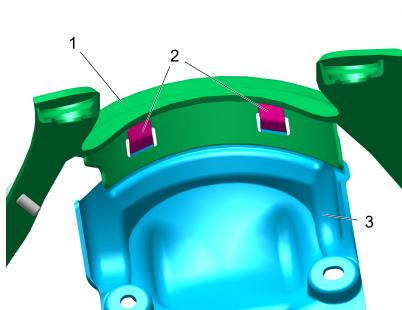

1. Rear hugger and chain guard
2. Retaining tangs
3. Linkage guard

- ▼ Position the two locating slots at the front end of the rear hugger and chain guard onto the retaining grommets.
- ▼ Install the two fasteners and tighten to 35 lbf in (4 Nm).

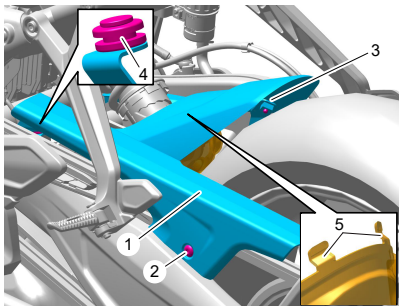

1. Rear hugger and chain guard (Trident 660 shown)
2. Fastener (left hand side)
3. Fastener (right hand side)
4. Retaining grommets (left hand side shown)
5. Retaining tangs (on the linkage guard)

Brakes

Breaking-in New Brake Discs and Pads

WARNING

Brake pads must always be replaced as a wheel set. At the front, where two calipers are installed on the same wheel, replace all the brake pads in both calipers.

After replacement brake pads have been installed, ride with extreme caution until the new pads have 'broken in'.

Replacing individual pads will reduce braking efficiency and may lead to loss of motorcycle control, which could result in serious injury or death.

New brake discs and pads require a period of careful breaking-in that will optimize the performance and longevity of the discs and pads.

The recommended distance for breaking-in new pads and discs is 200 miles (300 km).

During the breaking-in period, avoid extreme braking, ride with caution and allow for greater braking distances.

Brake Pad Wear Compensation

WARNING

If the brake lever or pedal feels soft when it is applied, or if the lever/pedal travel becomes excessive, there may be air in the brake lines and hoses or the brakes may be defective.

The fault must be checked and rectified by a competent person with the specialist knowledge and technical understanding of motorcycles, such as an authorized Triumph dealer.

Riding with defective brakes may lead to a dangerous riding condition, leading to loss of motorcycle control, which could result in serious injury or death.

Disc and brake pad wear is automatically compensated for and has no effect on the brake lever or pedal action. There are no parts that require adjustment on the front and rear brakes.

MAINTENANCE AND ADJUSTMENT

Front Brake Wear Inspection

⚠ WARNING

The use of proprietary brands of brake pads is not recommended as these may have a reduced carrier plate thickness when compared with the Triumph genuine parts.

Brake pads with an incorrect carrier plate thickness can potentially become dislodged from the caliper body as they wear, leading to brake failure, loss of motorcycle control and an accident.

Failure to follow the advice above could result in serious injury or death.

Brake pads must be inspected in accordance with scheduled requirements and replaced if worn to, or beyond the minimum service thickness.

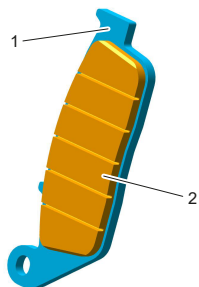

1. Carrier plate (Trident 660 shown)
2. Brake pad lining

Brake pads for this model supplied by Triumph will have the carrier plate at the recommended thickness. We recommend that the brake pads are changed by a competent person with the specialist knowledge and technical understanding of motorcycles, such as an authorized Triumph dealer.

If the lining thickness of any brake pad is less than that specified in the table, replace all the brake pads on the wheel.

Model	Minimum Brake Pad Lining Thickness
Trident 660	0.06 in (1.5 mm)
Trident 660 - Triple Tribute	0.06 in (1.5 mm)
Trident 800	0.043 in (1.1 mm)
Tiger Sport 660	0.06 in (1.5 mm)
Tiger Sport 800	0.043 in (1.1 mm)
Tiger Sport 800 Tour	0.043 in (1.1 mm)
Daytona 660	0.043 in (1.1 mm)

Rear Brake Wear Inspection

⚠ WARNING

The use of proprietary brands of brake pads is not recommended as these may have a reduced carrier plate thickness when compared with the Triumph genuine parts.

Brake pads with an incorrect carrier plate thickness can potentially become dislodged from the caliper body as they wear, leading to brake failure, loss of motorcycle control and an accident.

Failure to follow the advice above could result in serious injury or death.

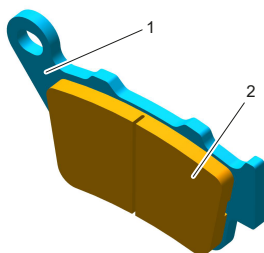

1. Carrier plate (Trident 660 shown)
2. Brake pad lining

Brake pads for this model supplied by Triumph will have the carrier plate at the recommended thickness. We recommend that the brake pads are changed by a competent person with the specialist knowledge and technical understanding of motorcycles, such as an authorized Triumph dealer.

If the lining thickness of any brake pad is less than that specified in the table, replace all the brake pads on the wheel.

Model	Minimum Brake Pad Lining Thickness
Trident 660	0.031 in (0.8 mm)
Trident 800	0.031 in (0.8 mm)
Trident 660 - Triple Tribute	0.031 in (0.8 mm)
Tiger Sport 660	0.031 in (0.8 mm)
Tiger Sport 800 Tour	0.031 in (0.8 mm)
Tiger Sport 800	0.031 in (0.8 mm)
Daytona 660	0.031 in (0.8 mm)

Disc Brake Fluid**⚠ WARNING**

Brake fluid is hygroscopic, which means it will absorb moisture from the air.

Any absorbed moisture will greatly reduce the boiling point of the brake fluid, causing a reduction in braking efficiency.

Because of this, always replace brake fluid in accordance with scheduled maintenance requirements.

Always use new brake fluid from a sealed container, and never use fluid from an unsealed container or from one that has been previously opened.

Do not mix different brands or grades of brake fluid.

Check for fluid leakage around brake installed, seals and joints and also check the brake hoses for splits, deterioration and damage.

Always rectify any faults before riding.

Failure to follow the advice above may lead to loss of motorcycle control, which could result in serious injury or death.

⚠ WARNING

If the ABS is not functioning, the brake system will continue to function as a non-ABS equipped brake system. Reduce speed and do not continue to ride for longer than is necessary with the ABS warning light illuminated.

The fault must be checked and rectified by a competent person with the specialist knowledge and technical understanding of motorcycles, such as an authorized Triumph dealer.

Braking too hard will cause the wheels to lock, leading to loss of motorcycle control, which could result in serious injury or death.

Inspect the level of brake fluid in both reservoirs and change the brake fluid in accordance with scheduled maintenance requirements. Use Triumph Performance DOT 4 brake fluid as recommended in the Specification section. The brake fluid must also be changed if it becomes, or is suspected of having become contaminated with moisture or any other contaminants.

NOTICE

A special tool is required to bleed the braking system. When the brake fluid needs replacing or the hydraulic system requires maintenance, contact a competent person with the specialist knowledge and technical understanding of motorcycles, such as an authorized Triumph dealer.

Front Brake Fluid Level Inspection and Adjustment

⚠ WARNING

If there has been an appreciable drop in the level of the fluid in either fluid reservoir, the brake system must be inspected.

If the brake lever or pedal feels soft when it is applied, or if the lever/pedal travel becomes excessive, there may be air in the brake lines or the brake may be defective.

Riding with depleted brake fluid levels, or with a brake fluid leak is dangerous and will cause reduced brake performance.

Contact a competent person with the specialist knowledge and technical understanding of motorcycles, such as an authorized Triumph dealer to inspect and, if necessary, repair the brake system.

Failure to follow the advice above may lead to loss of motorcycle control, which could result in serious injury or death.

NOTICE

To prevent paint damage, do not spill brake fluid onto any area of the bodywork.

Spilled brake fluid will damage paintwork.

The front brake fluid reservoir is located on the right hand side handlebar.

Front Brake Fluid Level Inspection

- ▼ Check the level of brake fluid visible in the window at the front of the reservoir.
- ▼ The brake fluid level must be kept between the upper and lower level lines (reservoir held horizontal).

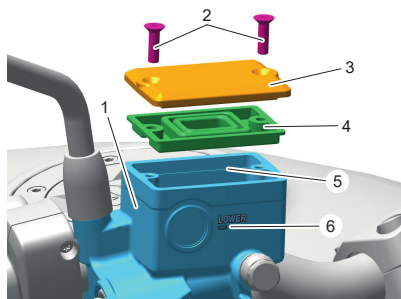

1. Front brake fluid reservoir (Trident 660 shown)
2. Reservoir cap retaining screws
3. Reservoir cap
4. Diaphragm seal
5. Upper level line
6. Lower level line

Front Brake Fluid Level Adjustment

- ▼ Loosen the reservoir cap retaining screws and remove the reservoir cap and the diaphragm seal.
- ▼ Fill the reservoir to the upper level line using new DOT 4 brake fluid from a sealed container. Triumph Performance DOT 4 brake fluid is recommended.
- ▼ Check the condition of the diaphragm seal. Replace if necessary.
- ▼ Install the reservoir cap making sure that the diaphragm seal is correctly positioned between the reservoir cap and the reservoir.

MAINTENANCE AND ADJUSTMENT

⚠ WARNING

Do not over tighten reservoir cap fasteners .

Over tightened reservoir cap fasteners may damage the brake fluid reservoir causing a brake fluid leak, leading to reduced braking efficiency.

Failure to follow the advice above may lead to loss of motorcycle control, which could result in serious injury or death.

- ▼ Tighten the reservoir cap retaining screws to 13.3 lbf in (1.5 Nm).

Rear Brake Fluid Level Inspection and Adjustment

⚠ WARNING

If there has been an appreciable drop in the level of the fluid in either fluid reservoir, the brake system must be inspected.

If the brake lever or pedal feels soft when it is applied, or if the lever/pedal travel becomes excessive, there may be air in the brake lines or the brake may be defective.

Riding with depleted brake fluid levels, or with a brake fluid leak is dangerous and will cause reduced brake performance.

Contact a competent person with the specialist knowledge and technical understanding of motorcycles, such as an authorized Triumph dealer to inspect and, if necessary, repair the brake system.

Failure to follow the advice above may lead to loss of motorcycle control, which could result in serious injury or death.

NOTICE

To prevent paint damage, do not spill brake fluid onto any area of the bodywork.

Spilled brake fluid will damage paintwork.

The rear brake fluid reservoir is visible from the right hand side of the motorcycle, forward of the muffler and below the rider's seat.

Rear Brake Fluid Level Inspection

- ▼ Check the level of brake fluid visible in the reservoir.
- ▼ The brake fluid level must be kept between the upper and lower level lines (reservoir held horizontal).

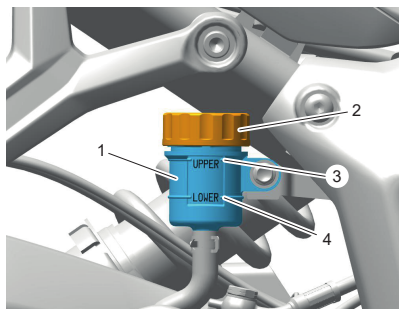

1. Rear brake fluid reservoir (Trident 660 shown)
2. Reservoir cap
3. Upper level line
4. Lower level line

Rear Brake Fluid Level Adjustment

- ▼ Loosen the reservoir cap and remove the diaphragm seal.
- ▼ Fill the reservoir to the upper level line using new DOT 4 brake fluid from a sealed container. Triumph Performance DOT 4 brake fluid is recommended.
- ▼ Install the reservoir cap making sure that the diaphragm seal is correctly installed.

Brake Light Switches

WARNING

Riding the motorcycle with defective brake lights is illegal and dangerous.

Before riding the motorcycle, make sure all lights are working.

Failure to follow the advice above could result in serious injury or death.

The brake light is activated independently by either the front or rear brake. If, with the ignition in the ON position, the brake light does not work when the front brake lever is pulled or the rear brake pedal is pressed, the fault must be checked and rectified by a competent person with the specialist knowledge and technical understanding of motorcycles, such as an authorized Triumph dealer.

Mirrors

WARNING

Always adjust the mirrors to provide sufficient rearward vision before riding the motorcycle.

Operation of the motorcycle with incorrectly adjusted mirrors is dangerous.

Operation of the motorcycle with incorrectly adjusted mirrors will result in loss of vision to the rear of the motorcycle. It is dangerous to ride a motorcycle without sufficient rearward vision.

Failure to follow the advice above could result in serious injury or death.

WARNING

Never attempt to clean or adjust mirrors while riding the motorcycle. Removal of the rider's hands from the handlebars while riding the motorcycle will diminish the ability of the rider to maintain control of the motorcycle.

Only attempt to clean or adjust the mirrors while stationary.

Attempting to clean or adjust mirrors while riding the motorcycle may lead to loss of motorcycle control, which could result in serious injury or death.

Models with Bar End Mirrors

⚠ WARNING

Incorrect adjustment of the bar end mirrors may cause the mirror arm to come into contact with the fuel tank, brake or clutch levers, or other parts of the motorcycle.

This will restrict brake or clutch lever operation or restrict steering movement which may affect the handling, stability or other aspects of the motorcycle's operation.

Adjust the mirrors as required to make sure they do not come into contact with any part of the motorcycle. After adjustment, move the handlebar to the left and right full lock, while checking that the mirrors do not contact the fuel tank, brake or clutch levers, or other parts of the motorcycle.

Failure to follow the advice above may lead to loss of motorcycle control, which could result in serious injury or death.

NOTICE

Incorrect adjustment of the bar end mirrors may cause the mirror arm to come into contact with the fuel tank, brake or clutch levers, or other parts of the motorcycle.

This will result in damage to the fuel tank, brake or clutch levers, or other parts of the motorcycle.

Adjust the mirrors as required to make sure they do not come into contact with any part of the motorcycle. After adjustment, move the handlebar to the left and right full lock, while checking that the mirrors do not contact the fuel tank, brake or clutch levers, or other parts of the motorcycle.

The bar end mirrors will be set by your authorized Triumph dealer and will not normally require any adjustment. Should adjustment be necessary, do not rotate the mirror beyond 75°, measured from the vertical section of the mirror arm.

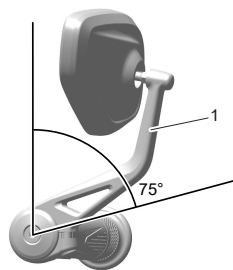

1. Mirror arm vertical section

Mirror Adjustment

⚠ WARNING

Make sure that the motorcycle is stabilized and adequately supported.

Do not support the motorcycle on any ancillary component, the exhaust system or any other non-structural parts of the motorcycle frame.

A correctly supported motorcycle will help prevent it from falling.

Failure to follow the advice above could result in serious injury or death.

Trident 660, Trident 660 - Triple Tribute, Trident 800, Tiger Sport 660, Tiger Sport 800 and Tiger Sport 800 Tour

NOTICE

The right mirror arm and lock nut has a left hand thread.

The left mirror arm and lock nut has a right hand thread.

- ▼ Lift the rubber cover to access the lock nut and mirror boss.
- ▼ Counter-hold the mirror boss and loosen the mirror lock nut.
- ▼ Position the mirror arm to give rear visibility in the riding position and tighten the lock nut by hand.

NOTICE

Use an open ended spanner to counter-hold the mirror boss as the mirror lock nut is loosened/tightened. Failure to counter-hold the boss will cause damage to the thread and the mirror to become loose.

- ▼ Counter-hold the mirror boss and tighten the mirror lock nut to 13 lb ft (13 lbf ft (17 Nm)).
- ▼ Slide the rubber cover over the lock nut.

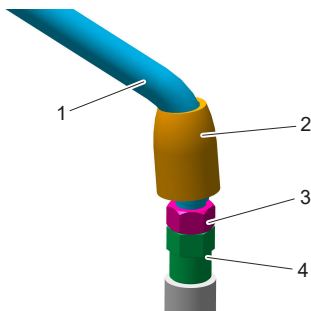

1. Mirror arm
2. Rubber cover
3. Lock nut
4. Mirror boss

Daytona 660

- ▼ Move the mirror arm forwards or rearwards to give rear visibility in the riding position.

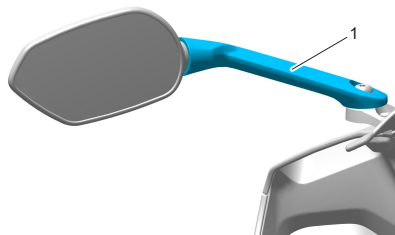

1. Mirror arm

MAINTENANCE AND ADJUSTMENT

Steering/Wheel Bearings

⚠ WARNING

To prevent risk of injury from the motorcycle falling during the inspection, make sure that the motorcycle is stabilized and secured on a suitable support.

When inspecting steering and wheel bearings, do not exert extreme force against each wheel or rock each wheel vigorously, as this may cause the motorcycle to become unstable and fall from its support.

Failure to follow the advice above could result in motorcycle damage, serious injury or death.

Steering Bearings Inspection

⚠ WARNING

Make sure that the motorcycle is stabilized and adequately supported.

Do not support the motorcycle on any ancillary component, the exhaust system or any other non-structural parts of the motorcycle frame.

A correctly supported motorcycle will help prevent it from falling.

Failure to follow the advice above could result in serious injury or death.

⚠ WARNING

Never neglect steering (steering head) bearings maintenance. Check the steering bearings in accordance with scheduled maintenance requirements and make adjustments or replace as necessary.

Scheduled maintenance must be carried out by a competent person with the specialist knowledge and technical understanding of motorcycles, such as an authorized Triumph dealer.

Riding the motorcycle with incorrectly adjusted or defective steering bearings is dangerous and may lead to loss of motorcycle control, which could result in serious injury or death.

The steering head bearings must be lubricated and inspected in accordance with scheduled maintenance requirements.

NOTICE

Always inspect the wheel bearings at the same time as the steering bearings.

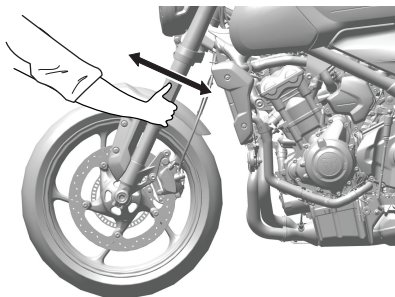

Inspecting the Steering for Free Play
(Trident 660 shown)

- ▼ Position the motorcycle on level ground, in an upright position.
- ▼ Raise the front wheel above the ground and support the motorcycle.
- ▼ Standing at the front of the motorcycle, hold the lower end of the front forks and try to move them forward and backward.
- ▼ If any free play can be detected in the steering (steering head) bearings, the steering bearings must be inspected and adjusted by a competent person with the specialist knowledge and technical understanding of motorcycles, such as an authorized Triumph dealer.
- ▼ Remove the support and place the motorcycle on the side stand.

Wheel Bearings Inspection

! WARNING

Make sure that the motorcycle is stabilized and adequately supported.

Do not support the motorcycle on any ancillary component, the exhaust system or any other non-structural parts of the motorcycle frame.

A correctly supported motorcycle will help prevent it from falling.

Failure to follow the advice above could result in serious injury or death.

! WARNING

Never neglect wheel bearings maintenance. Check the wheel bearings in accordance with scheduled maintenance requirements and make adjustments or replace as necessary.

Scheduled maintenance must be carried out by a competent person with the specialist knowledge and technical understanding of motorcycles, such as an authorized Triumph dealer.

Riding the motorcycle with worn or damaged wheel bearings is dangerous and may lead to loss of motorcycle control, which could result in serious injury or death.

The wheel bearings must be inspected at the intervals specified in the scheduled maintenance chart.

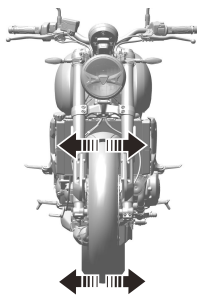

**Inspecting the Wheel Bearings
(Trident 660 shown)**

NOTICE

If the wheel bearings in the front or rear wheel allow play in the wheel hub, are noisy, or if the wheel does not turn smoothly, the wheel bearings must be inspected by a competent person with the specialist knowledge and technical understanding of motorcycles, such as an authorized Triumph dealer.

- ▼ Position the motorcycle on level ground, in an upright position.
- ▼ Raise the front wheel off the ground and support the motorcycle.
- ▼ Standing at the side of the motorcycle, gently rock the top of the front wheel from side to side.
- ▼ If any free play can be detected in the wheel bearings, the wheel bearings must be inspected and replaced by a competent person with the specialist knowledge and technical understanding of motorcycles, such as an authorized Triumph dealer.
- ▼ Reposition the suitable stand and repeat the procedure for the rear wheel.
- ▼ Remove the support and place the motorcycle on the side stand.

Suspension**⚠ WARNING**

Imbalance between the front and rear suspension will affect the handling and stability.

Always adjust the suspension settings as shown in the settings tables.

Failure to follow the advice above may lead to loss of motorcycle control, which could result in serious injury or death.

The Daytona 660, Tiger Sport 800, Trident 800 and Tiger Sport 800 Tour are equipped with adjustable front and rear suspension. All other models have non-adjustable front suspension and adjustable rear suspension.

The Standard suspension settings provide a comfortable ride and good handling characteristics for general, solo riding. The following tables show suggested settings for the front and rear suspension.

Front Fork Inspection

! WARNING

Never neglect front fork maintenance. Check the front forks in accordance with scheduled maintenance requirements and make adjustments or replace as necessary.

Scheduled maintenance must be carried out by a competent person with the specialist knowledge and technical understanding of motorcycles, such as an authorized Triumph dealer.

Riding with defective or damaged suspension components is dangerous and may lead to loss of motorcycle control, which could result in serious injury or death.

! CAUTION

All suspension units contain pressurized oil.

Do not attempt to dismantle any part of the suspension units. Inspections and repairs must be completed by a competent person with the specialist knowledge and technical understanding of motorcycles, such as an authorized Triumph dealer.

! CAUTION Continued

Accidental release of pressurized oil or springs could result in minor to moderate injury.



Inspecting the Front Forks (Trident 660 shown)

- ▼ Position the motorcycle on level ground.
- ▼ While holding the handlebars and applying the front brake, pump the forks up and down several times.
- ▼ Check for roughness or excessive stiffness.
- ▼ Examine each fork for any sign of damage, scratching of the slider surface, or for oil leaks.

If a problem is detected or any doubt exists, the forks must be inspected by a competent person with the specialist knowledge and technical understanding of motorcycles, such as an authorized Triumph dealer.

MAINTENANCE AND ADJUSTMENT

Suspension Settings

The motorcycle is delivered from the factory with all the suspension settings set at the Standard setting, as shown in the relevant suspension settings tables.

The details shown in the suspension settings tables are only a guide. Setting requirements may vary for rider and passenger weight and personal preferences.

NOTICE

Always set the front and rear suspension to the same loading condition, as shown in the tables below.

Tiger Sport 800 and Tiger Sport 800 Tour Only

Front Suspension Settings		
Loading Condition	Rebound Damping ¹	Compression Damping ¹
Solo Riding - Standard	1.75	1.75
Solo Riding - Comfort (Softer)	2.5	2.5
Solo Riding - Sport (Firmer)	1	1
Rider and Passenger with Luggage (not exceeding limits)	As per Solo Riding	As per Solo Riding

¹ Number of adjuster turns counterclockwise from the fully clockwise position.

Trident 800 Only

Front Suspension Settings		
Loading Condition	Rebound Damping ¹	Compression Damping ¹
Solo Riding - Standard	2.75	3.5
Solo Riding - Comfort (Softer)	5	7
Solo Riding - Sport (Firmer)	1	1
Rider and Passenger with Luggage (not exceeding limits)	As per Solo Riding	As per Solo Riding

¹ Number of adjuster turns counterclockwise from the fully clockwise position.

Daytona 660 Only

Front Suspension Settings		
Loading Condition	Rebound Damping ¹	Compression Damping ¹
Solo Riding - Standard	3	4.5
Solo Riding - Comfort (Softer)	5	7
Solo Riding - Sport (Firmer)	1	1.5
Rider and Passenger with Luggage (not exceeding limits)	As per Solo Riding	As per Solo Riding

¹ Number of adjuster turns counterclockwise from the fully clockwise position.

For front suspension adjustment, see page 211 and/or page 212.

Trident 660, Trident 660 - Triple Tribute and Daytona 660

Rear Suspension Settings	
Loading Condition	Spring Preload ¹
Solo Riding	MIN
Solo Riding with Luggage (not exceeding limits)	MIN
Rider and Passenger	MAX
Rider and Passenger with Luggage (not exceeding limits)	MAX

¹ Position 1 is minimum (fully clockwise) and position 7 is maximum (fully counterclockwise).

Trident 800

Rear Suspension Settings		
Loading Condition	Spring Preload ¹	Rebound Damping ²
Solo Riding - Standard	MIN	1
Solo Riding - Comfort (Softer)	MIN	MIN
Solo Riding - Sport (Firmer)	MIN	0.5
Rider and Passenger	MAX	0.5

¹ Position 1 is minimum (fully clockwise) and position 7 is maximum (fully counterclockwise).
² Number of adjuster turns counterclockwise from the fully clockwise position.

MAINTENANCE AND ADJUSTMENT

Tiger Sport 660

Rear Suspension Settings	
Loading Condition	Spring Preload ¹
Solo Riding	MIN
Solo Riding with Luggage (not exceeding limits)	30
Rider and Passenger	MAX
Rider and Passenger with Luggage (not exceeding limits)	MAX

¹ Number of clicks clockwise from the fully counterclockwise position, noting that the first stop (click) is counted as one.

Tiger Sport 800 and Tiger Sport 800 Tour Only

Rear Suspension Settings		
Loading Condition	Spring Preload ¹	Rebound Damping ²
Solo Riding - Standard	MIN	1.25
Solo Riding - Comfort (Softer)	MIN	2
Solo Riding - Sport (Firmer)	MIN	0.5
Solo Riding with Luggage (not exceeding limits)	30	0.25
Rider and Passenger with Luggage (not exceeding limits)	MAX	0.25

¹ Number of clicks clockwise from the fully counterclockwise position, noting that the first stop (click) is counted as one.

² Number of adjuster turns counterclockwise from the fully clockwise position.

For rear suspension adjustment, see page 213 and/or page 214.

Front Suspension Rebound Damping Adjustment

Tiger Sport 800 and Tiger Sport 800 Tour

The rebound damping adjuster is located at the top of the right hand fork.

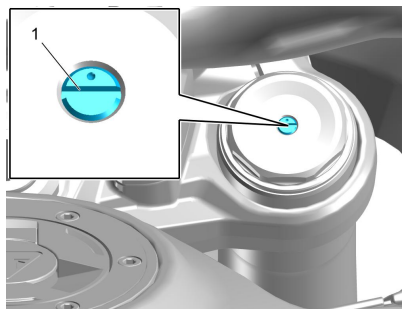

1. Front suspension rebound damping adjuster

- ▼ Turn the slotted adjuster clockwise to increase, or counterclockwise to decrease rebound damping.
- ▼ Always count the number of adjuster turns counterclockwise from the fully clockwise position.

Daytona 660 and Trident 800

The rebound damping adjuster is located at the top of the left hand fork.

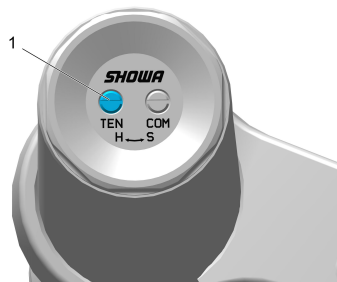

1. Front suspension rebound damping adjuster

- ▼ Turn the slotted adjuster clockwise to increase, or counterclockwise to decrease rebound damping.
- ▼ Always count the number of adjuster turns counterclockwise from the fully clockwise position.

MAINTENANCE AND ADJUSTMENT

Front Suspension Compression Damping Adjustment

Tiger Sport 800 and Tiger Sport 800 Tour

The compression damping adjuster is located at the top of the left hand fork.

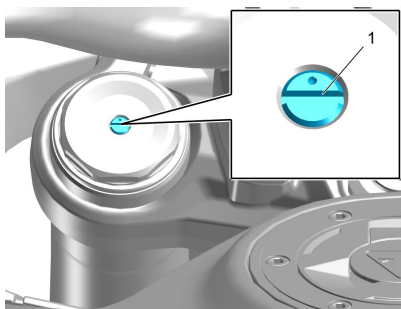

1. Front suspension compression damping adjuster

- ▼ Turn the slotted adjuster clockwise to increase, or counterclockwise to decrease compression damping.
- ▼ Always count the number of adjuster turns counterclockwise from the fully clockwise position.

Daytona 660 and Trident 800

The compression damping adjuster is located at the top of the left hand fork.

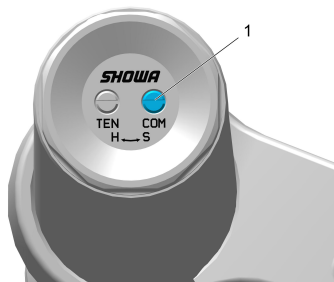

1. Front suspension compression damping adjuster

- ▼ Turn the slotted adjuster clockwise to increase, or counterclockwise to decrease compression damping.
- ▼ Always count the number of adjuster turns counterclockwise from the fully clockwise position.

Rear Suspension Spring Preload Adjustment

Trident 660, Trident 660 - Triple Tribute, Daytona 660 and Trident 800

The spring preload adjuster is located at the bottom of the rear suspension unit.

Rear adjuster settings are counted from one, with position one being with the adjuster turned fully clockwise. Position one gives the minimum amount of spring preload. There are seven adjuster positions in total. Position seven gives the maximum amount of spring preload.

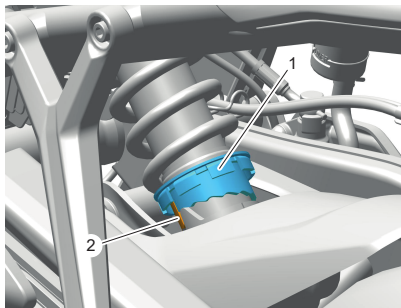

1. Spring preload adjuster ring (minimum position shown) (Trident 660 shown)
2. Adjuster ring stopper

- ▼ Locate the C-spanner supplied in the tool kit.
- ▼ Insert the C-spanner into the slots of the spring preload adjuster ring.
- ▼ Turn the adjuster ring counterclockwise towards the left hand side of the motorcycle to increase spring preload.
- ▼ Turn the adjuster ring clockwise towards the right hand side of the motorcycle to decrease spring preload.

Tiger Sport 660, Tiger Sport 800 and Tiger Sport 800 Tour

The spring preload adjuster is located near to the rear suspension unit and is accessible from the left hand side of the motorcycle.

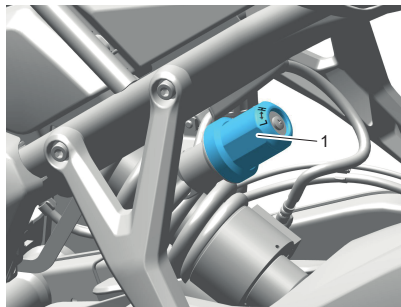

1. Spring preload adjuster (Tiger Sport 660 shown)

- ▼ Turn the adjuster clockwise towards the right hand side of the motorcycle to increase spring preload.
- ▼ Turn the adjuster counterclockwise towards the left hand side of the motorcycle to decrease spring preload.
- ▼ Always count the number of clicks clockwise from the fully counterclockwise position, noting that the first stop (click) is counted as one.

MAINTENANCE AND ADJUSTMENT

Rear Suspension Rebound Damping Adjustment

The rebound damping adjuster is located at the top of the rear suspension unit and is accessible from the left hand side of the motorcycle.

Tiger Sport 800 and Tiger Sport 800 Tour

- ▼ Turn the slotted adjuster clockwise to increase, or counterclockwise to decrease rebound damping.
- ▼ Always count the number of adjuster turns counterclockwise from the fully clockwise position.

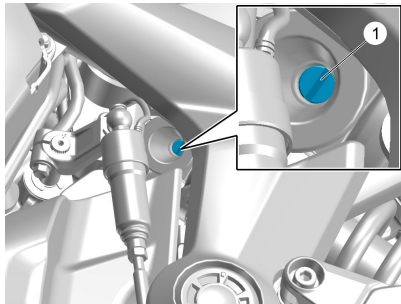

1. Rear suspension rebound damping adjuster

Trident 800

NOTICE

For visual clarity, the Triumph shift assist is detached from the gear shift clamp in the illustration.

- ▼ Turn the slotted adjuster clockwise to increase, or counterclockwise to decrease rebound damping.
- ▼ Always count the number of adjuster turns counterclockwise from the fully clockwise position.

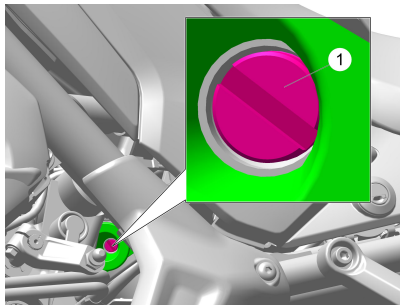

1. Rear suspension rebound damping adjuster

Bank Angle Indicators

⚠ WARNING

Always replace the bank angle indicators before they are worn to their maximum limit.

Use of a motorcycle with bank angle indicators worn beyond the maximum limit will allow the motorcycle to be banked to an unsafe angle.

Banking to an unsafe angle may lead to loss of motorcycle control, which could result in serious injury or death.

⚠ WARNING

The bank angle indicators must not be used as a guide to how far the motorcycle may be safely banked.

This depends on many various conditions including, but not limited to:

- Road surface
- Tire condition
- Weather.

Banking to an unsafe angle may lead to loss of motorcycle control, which could result in serious injury or death.

Bank angle indicators are located on the rider's footrests.

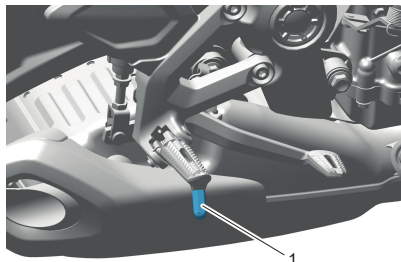

1. Bank angle indicator (Trident 660 shown)

Regularly check the bank angle indicators for wear.

The bank angle indicators must be replaced when they have reached the minimum length remaining as specified in the table.

Model	Minimum Bank Angle Indicator Length
Trident 660	0.59 in (15 mm)
Trident 660 - Triple Tribute	0.59 in (15 mm)
Trident 800	0.59 in (15 mm)
Tiger Sport 660	0.2 in (5 mm)
Tiger Sport 800	0.59 in (15 mm)
Daytona 660	0.2 in (5 mm)

MAINTENANCE AND ADJUSTMENT

Tires



The motorcycle is equipped with cast wheels.

Models with cast wheels are equipped with tubeless tires, valves and wheel rims. Use only tires marked 'TUBELESS' and tubeless valves on rims marked 'SUITABLE FOR TUBELESS TIRES'.

⚠ WARNING

Do not install tube type tires on tubeless rims. The bead will not seat and the tires could slip on the rims, causing rapid tire deflation.

Never install an inner tube inside a tubeless tire without the appropriate marking. This will cause friction inside the tire and the resulting heat build-up may cause the tube to burst resulting in rapid tire deflation.

Failure to follow the advice above may lead to loss of motorcycle control, which could result in serious injury or death.



Typical Tire Marking - Tubeless Tire

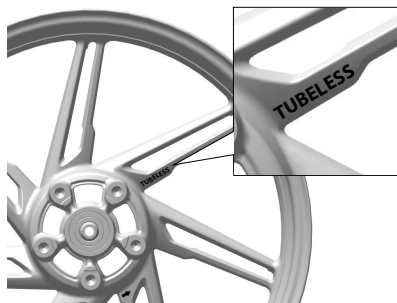

Typical Wheel Marking - Tubeless Tire

Tire Inflation Pressures

WARNING

Incorrect tire inflation will cause abnormal tread wear and instability.

Underinflation may result in the tire slipping on, or coming off the rim. Overinflation will cause accelerated tread wear and instability.

Both conditions are dangerous and may lead to loss of motorcycle control, which could result in serious injury or death.

Correct inflation pressure will provide maximum stability, rider comfort and tire life. Always check tire pressures before riding when the tires are cold. Check tire pressures daily and adjust if necessary. See the Specification section for details of the correct inflation pressures.

Tire Pressure Monitoring System (TPMS) (if equipped)

NOTICE

An adhesive label is installed to the wheel rim to indicate the position of the tire pressure sensor.

Care must be taken when replacing the tires to prevent any damage to the tire pressure sensors.

Always have the tires mounted by a competent person with the specialist knowledge and technical understanding of motorcycles, such as an authorized Triumph dealer. It is important to inform them that tire pressure sensors are installed on the wheels before they remove the tires.

NOTICE

Do not use anti puncture fluid or any other item likely to obstruct air flow to the TPMS sensors' orifices. Any blockage to the air pressure orifice of the TPMS sensor during operation will cause the sensor to become blocked, causing irreparable damage to the TPMS sensor assembly.

Damage caused by the use of anti-puncture fluid or incorrect maintenance is not considered a manufacturing defect and will not be covered under warranty.

Always have the tires mounted by a competent person with the specialist knowledge and technical understanding of motorcycles, such as an authorized Triumph dealer. It is important to inform them that tire pressure sensors are installed on the wheels before they remove the tires.

The tire pressures shown on your instruments indicate the actual tire pressure at the time of selecting the display. This may differ from the inflation pressure set when the tires are cold because tires become warmer during riding, causing the air in the tire to expand and increase the inflation pressure. The cold inflation pressures specified by Triumph take account of this.

Only adjust tire pressures when the tires are cold using an accurate pressure gage. Do not use the tire pressure display on the instruments.

MAINTENANCE AND ADJUSTMENT

Tire Wear

As the tire tread wears down, the tire becomes more susceptible to punctures and failure. It is estimated that 90% of all tire problems occur during the last 10% of tread life (90% worn). It is recommended that tires are changed before they are worn to their minimum tread depth.

Minimum Recommended Tread Depth

WARNING

Riding with damaged or defective wheels and/or excessively worn, punctured or damaged tires will affect traction, handling and stability.

When tubeless tires become punctured, leakage is often very slow. Always inspect tires very closely for punctures. Check the tires for cuts, embedded nails or other sharp objects. Check the wheel rims for dents or deformation.

For tire replacement or for a safety inspection of the tires, contact a competent person with the specialist knowledge and technical understanding of motorcycles, such as an authorized Triumph dealer.

Riding with damaged wheels and tires is dangerous and may lead to loss of motorcycle control, which could result in serious injury or death.

In accordance with the periodic maintenance chart, measure the depth of the tread with a depth gage, and replace any tire that has worn to, or beyond, the minimum allowable tread depth specified in the table below:

Under 80 mph (130 km/h)	0.08 in (2 mm)
Over 80 mph (130 km/h)	Front 0.08 in (2 mm) Rear 0.12 in (3 mm)

Tire Replacement

All Triumph motorcycles are carefully and extensively tested in a range of riding conditions to make sure that the most effective tire combinations are approved for use on each model.

It is essential that approved tires mounted in approved combinations, are used when purchasing replacement items.

The use of non-approved tires or approved tires in non-approved combinations, may lead to motorcycle instability, loss of control and an accident.

A list of approved tires specific to your motorcycle are available from your authorized Triumph dealer, or on the Internet at www.triumphtechnicalinformation.com/tyres.

Or;

Scan the QR code using your smart device:



Tires must be selected in the correct combination, from the approved Tire Selector. Tires must be mounted and balanced according to the tire manufacturer's instructions.

When replacement tires are required, contact a competent person with the specialist knowledge and technical understanding of motorcycles, such as an authorized Triumph dealer.

Initially, the new tires will not produce the same handling characteristics as the worn tires and the rider must allow adequate riding distance (approximately 100 miles (160 km)) to become accustomed to the new handling characteristics.

The tire pressures must be checked and adjusted, and the tires examined for correct seating 24 hours after mounting. Rectification must be carried out as necessary. The same checks and adjustments must also be carried out when 100 miles (160 km) have been traveled after mounting.

WARNING

Use the recommended tires **ONLY** in the combinations listed in the approved Tire Selector at www.triumphtechnicalinformation.com/tyres.

Do not mix tires from different manufacturers or mix different specification tires from the same manufacturers.

Using/mixing tires may affect the handling, stability, braking and traction control (if equipped) functions of the motorcycle.

Failure to follow the advice above may lead to loss of motorcycle control, which could result in serious injury or death.

WARNING

Do not install tube type tires on tubeless rims. The bead will not seat and the tires could slip on the rims, causing rapid tire deflation.

Never install an inner tube inside a tubeless tire without the appropriate marking. This will cause friction inside the tire and the resulting heat build-up may cause the tube to burst resulting in rapid tire deflation.

Failure to follow the advice above may lead to loss of motorcycle control, which could result in serious injury or death.

MAINTENANCE AND ADJUSTMENT

WARNING

If a tire sustains a puncture, the tire must be replaced.

Operation of the motorcycle with a punctured or repaired tire may adversely affect the motorcycle stability.

Failure to follow the advice above may lead to loss of motorcycle control, which could result in serious injury or death.

WARNING

If tire damage is suspected, such as after striking an object, the tire must be inspected both internally and externally by a competent person with the specialist knowledge and technical understanding of motorcycles, such as an authorized Triumph dealer.

Tire damage may not always be visible from the outside.

Operation of the motorcycle with damaged tires may lead to loss of motorcycle control, which could result in serious injury or death.

WARNING

Do not use the motorcycle with incorrectly seated tires or incorrectly adjusted tire pressures.

Incorrectly seated tires or incorrectly adjusted tire pressures may affect the handling, stability or other aspects of the motorcycle operation.

Failure to follow the advice above may lead to loss of motorcycle control, which could result in serious injury or death.

WARNING

ABS operates by comparing the relative speed of the front and rear wheels.

Use of non-recommended tires can affect wheel speed and cause the ABS function not to operate in conditions where the ABS would normally function.

A list of approved tires specific to these models is available from your authorized Triumph dealer, or on the Internet at www.triumphtechnicalinformation.com/tyres.

Failure to follow the advice above may lead to loss of motorcycle control, which could result in serious injury or death.

WARNING

Accurate wheel balance is necessary for safe, stable handling of the motorcycle. Do not remove or change any wheel balance weights. Incorrect wheel balance may cause instability.

Only use self-adhesive weights. Clip on weights may damage the wheel or tire resulting in tire deflation.

When wheel balancing is required, such as after tire replacement, contact a competent person with the specialist knowledge and technical understanding of motorcycles, such as an authorized Triumph dealer.

Failure to follow the advice above may lead to loss of motorcycle control, which could result in serious injury or death.

WARNING

Tires that have been used on a rolling road dynamometer may become damaged. In some cases, the damage may not be visible on the external surface of the tire.

Tires must be replaced after such use as continued use of a damaged tire may cause instability.

Failure to follow the advice above may lead to loss of motorcycle control, which could result in serious injury or death.

Battery

WARNING

The battery contains sulfuric acid (battery acid). Contact with skin or eyes may cause severe burns. Wear protective clothing and a face shield.

If battery acid gets on your skin, flush with water immediately.

If battery acid gets in your eyes, flush with water for at least 15 minutes and **SEEK MEDICAL ATTENTION IMMEDIATELY.**

If battery acid is swallowed, drink large quantities of water and **SEEK MEDICAL ATTENTION IMMEDIATELY.**

KEEP BATTERY ACID OUT OF THE REACH OF CHILDREN.

Failure to follow the advice above could result in serious injury or death.

WARNING

Make sure that there is adequate ventilation when charging or using the battery in an enclosed space.

Under certain circumstances, the battery may release explosive gases. Make sure to keep all sparks, flames and cigarettes away from the battery.

Do not attach jump leads to the battery, touch the battery cables together or reverse the polarity of the cables, as any of these actions may cause a spark which would ignite battery gases causing a risk of serious injury or death.

MAINTENANCE AND ADJUSTMENT

WARNING

The battery contains harmful materials.

Always keep children and pets away from the battery at all times.

Failure to follow the advice above could result in serious injury or death.

WARNING

Before disconnecting the battery or removing a fuse for any reason, note and record the riding modes settings.

Once the fuse has been remounted or the battery reconnected, the riding modes should be reset as noted.

Failure to reset the motorcycle riding modes settings and subsequently being ridden, may cause loss of motorcycle control, which could result in serious injury or death.

Battery - Removal

WARNING

Make sure that the motorcycle is stabilized and adequately supported.

Do not support the motorcycle on any ancillary component, the exhaust system or any other non-structural parts of the motorcycle frame.

A correctly supported motorcycle will help prevent it from falling.

Failure to follow the advice above could result in serious injury or death.

- ▼ Remove the seat, see page 116.

Trident 660, Trident 660 - Triple Tribute, Tiger Sport 660, Tiger Sport 800 and Tiger Sport 800 Tour

- ▼ Disconnect the diagnostics connector for ease of battery removal.
- ▼ Disconnect the battery negative (black) lead.
- ▼ Slide the positive (+) terminal protective cap to gain access to the fastener.
- ▼ Disconnect the battery positive (red) lead.
- ▼ Unhook the battery strap from its clip near the battery spacer.
- ▼ Remove the battery spacer.

WARNING

Make sure that the battery terminals do not touch the motorcycle frame.

This may cause a short circuit or spark which would ignite battery gases.

Failure to follow the advice above could result in serious injury or death.

- ▼ Remove the battery from its housing.

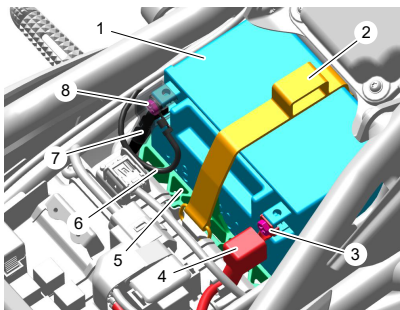

1. Battery (Trident 660 shown)
2. Battery strap
3. Positive (+) terminal
4. Positive (+) terminal protective cap
5. Battery spacer
6. ABS ground lead
7. Negative (-) lead
8. Negative (-) terminal

Trident 800

- ▼ Disconnect the ABS ground and battery negative (black) leads.
- ▼ Slide the positive (+) terminal protective cap to gain access to the fastener.
- ▼ Disconnect the battery positive (red) lead.
- ▼ Unhook the battery strap from its clip near the battery spacer.
- ▼ Remove the battery spacer.
- ▼ Remove the battery from its housing.

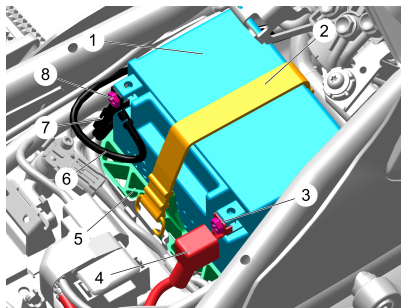

1. Battery
2. Battery strap
3. Positive (+) terminal
4. Positive (+) terminal protective cap
5. Battery spacer
6. ABS ground lead
7. Negative (-) lead
8. Negative (-) terminal

MAINTENANCE AND ADJUSTMENT

Daytona 660

- ▼ Disconnect the battery negative (black) lead.
- ▼ Slide the positive (+) terminal protective cap to gain access to the fastener.
- ▼ Disconnect the battery positive (red) lead.
- ▼ Unhook the battery strap from its clip near the battery spacer.
- ▼ Remove the battery spacer.
- ▼ Remove the battery from its housing.

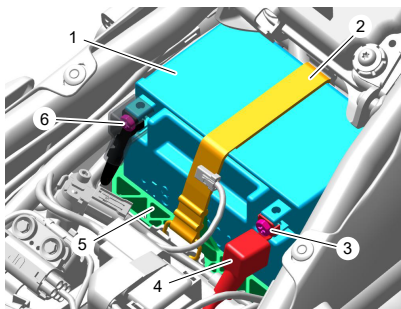

1. Battery
2. Battery strap
3. Positive (+) terminal
4. Positive (+) terminal protective cap
5. Battery spacer
6. Negative (-) terminal

Battery Disposal

Should the battery ever require replacement, the original battery must be handed to a recycling agent who will make sure that the dangerous substances from which the battery is manufactured do not pollute the environment.

Battery Maintenance

⚠ WARNING

Battery acid is corrosive and poisonous and will cause damage to unprotected skin.

Never swallow battery acid or allow it to come into contact with the skin.

To prevent injury, always wear eye and skin protection when handling the battery.

Failure to follow the advice above could result in serious injury or death.

The battery is a sealed type and does not require any maintenance other than checking the voltage and routine recharging when required, such as during storage.

Clean the battery using a clean, dry cloth. Make sure that the cable connections are clean.

It is not possible to adjust the battery acid level in the battery; the sealing strip must not be removed.

Battery Discharge

NOTICE

The charge level in the battery must be maintained to maximize battery life.

Failure to maintain the battery charge level could cause serious internal damage to the battery.

Under normal conditions, the motorcycle charging system will keep the battery fully charged. However, if the motorcycle is unused, the battery will gradually discharge due to a normal process called self-discharge; the clock, engine ECM memory, high ambient temperatures, or the addition of electrical security systems or other electrical accessories will all increase this rate of battery discharge. Disconnecting the battery from the motorcycle during storage will reduce the rate of discharge.

Battery Discharge During Storage and Infrequent Use of the Motorcycle

During storage or infrequent use of the motorcycle, inspect the battery voltage weekly using a multimeter. Follow the manufacturer's instructions supplied with the meter.

Should the battery voltage fall below 12.7 Volts, the battery should be charged.

Allowing a battery to discharge or leaving it discharged for even a short period of time causes sulphation of the lead plates. Sulphation is a normal part of the chemical reaction inside the battery, however over time the sulphate can crystallize on the plates making recovery difficult or impossible. This permanent damage is not covered by the motorcycle warranty, as it is not due to a manufacturing defect.

Keeping the battery fully charged reduces the likelihood of it freezing in cold conditions. Allowing a battery to freeze will cause serious internal damage to the battery.

Battery Charging

WARNING

The battery contains sulfuric acid (battery acid). Contact with skin or eyes may cause severe burns. Wear protective clothing and a face shield.

If battery acid gets on your skin, flush with water immediately.

If battery acid gets in your eyes, flush with water for at least 15 minutes and **SEEK MEDICAL ATTENTION IMMEDIATELY.**

If battery acid is swallowed, drink large quantities of water and **SEEK MEDICAL ATTENTION IMMEDIATELY.**

KEEP BATTERY ACID OUT OF THE REACH OF CHILDREN.

Failure to follow the advice above could result in serious injury or death.

NOTICE

Do not use an automotive quick charger as it may overcharge and damage the battery.

For help with selecting a battery charger, checking the battery voltage or battery charging, contact a competent person with the specialist knowledge and technical understanding of motorcycles, such as an authorized Triumph dealer.

For extended periods of storage (beyond two weeks) the battery should be removed from the motorcycle and kept charged using a Triumph approved maintenance charger.

Similarly, should the battery charge fall to a level where it will not start the motorcycle, remove the battery from the motorcycle before charging.

MAINTENANCE AND ADJUSTMENT

Should the battery voltage fall below 12.7 Volts, the battery should be charged using a Triumph approved battery charger. Always remove the battery from the motorcycle.

The Triumph recommended battery charger will come with a set of battery connector leads:

- ▼ A connector lead with ring terminals.
- ▼ A connector lead with crocodile clips.

To charge the battery, do the following:

- ▼ We recommend removing the battery from the motorcycle before charging.
 - If the battery needs to be charged when installed on the motorcycle, use the electrical accessory socket (if equipped) and a suitable connector lead with DIN plug or the connector lead with ring terminals (supplied with the Triumph recommended battery charger).
 - Do not use the USB socket (if equipped) to charge the motorcycle battery.
 - The connector lead with ring terminals (supplied with the Triumph recommended battery charger) can be installed on this model.
 - The connector lead with crocodile clips (supplied with the Triumph recommended battery charger) must not be used to charge the battery when it is mounted on the motorcycle.

- ▼ Follow the instructions supplied with the approved battery charger.
- ▼ Charge the battery with a lower current than the MAX Charging Current found on the charging label.
- ▼ If the battery becomes hot to the touch, stop charging and allow the battery to cool before resuming.
- ▼ After charging, leave the battery for 1 to 2 hours before checking the voltage. If the voltage is less than 12.9 Volts, additional charging is necessary.

Battery - Installation

WARNING

Make sure that the motorcycle is stabilized and adequately supported.

Do not support the motorcycle on any ancillary component, the exhaust system or any other non-structural parts of the motorcycle frame.

A correctly supported motorcycle will help prevent it from falling.

Failure to follow the advice above could result in serious injury or death.

WARNING

Make sure that the battery terminals do not touch the motorcycle frame.

This may cause a short circuit or spark which would ignite battery gases.

Failure to follow the advice above could result in serious injury or death.

NOTICE

A connector lead with a DIN plug is also available as an accessory from your Triumph dealer.

⚠ WARNING

Before disconnecting the battery or removing a fuse for any reason, note and record the riding modes settings.

Once the fuse has been remounted or the battery reconnected, the riding modes should be reset as noted.

Failure to reset the motorcycle riding modes settings and subsequently being ridden, may cause loss of motorcycle control, which could result in serious injury or death.

Trident 660, Trident 660 - Triple Tribute, Tiger Sport 660, Tiger Sport 800 and Tiger Sport 800 Tour

- ▼ Position the battery into its housing.
- ▼ Insert the battery spacer.
- ▼ Install the battery strap.

NOTICE

The battery positive and negative leads are to be connected to the vertical face of the battery terminals.

The battery positive lead routes underneath the diagnostic connector cable and clips to the Engine ECM molding.

- ▼ Reconnect the battery, positive (red) lead first and then the negative and ABS ground (black) leads, routing the positive lead underneath the diagnostic connector cable.

- ▼ Tighten the battery terminals to 40 lbf in (4.5 Nm).

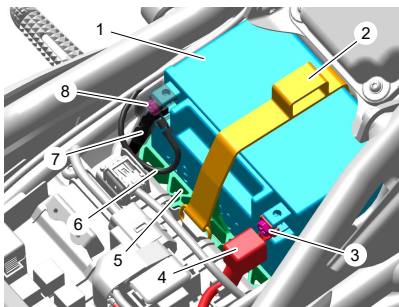

1. Battery (Trident 660 shown)
2. Battery strap
3. Positive (+) terminal
4. Positive (+) terminal protective cap
5. Battery spacer
6. ABS ground lead
7. Negative (-) lead
8. Negative (-) terminal

- ▼ Make sure the battery positive (red) lead is clipped to the engine ECM tray.

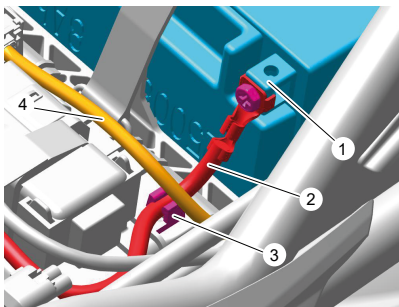

1. Battery positive terminal
2. Battery positive lead
3. Retaining feature on engine ECM molding
4. Diagnostic connector cable

- ▼ Apply a light coat of grease to the terminals to prevent corrosion.
- ▼ Cover the positive terminal with the protective cap.

MAINTENANCE AND ADJUSTMENT

- ▼ Reconnect the diagnostics connector.

Trident 800

- ▼ Position the battery into its housing.
- ▼ Insert the battery spacer.
- ▼ Install the battery strap.

NOTICE

The battery positive and negative leads are to be connected to the vertical face of the battery terminals.

The battery positive lead routes underneath the diagnostic connector cable and clips to the Engine ECM molding.

- ▼ Reconnect the battery, positive (red) lead first and then the negative and ABS ground (black) leads, routing the positive lead underneath the diagnostic connector cable.
- ▼ Tighten the battery terminals to 40 lbf in (4.5 Nm).

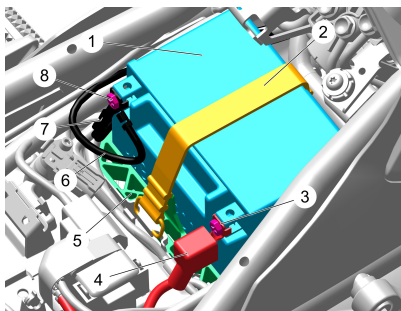

1. Battery
2. Battery strap
3. Positive (+) terminal
4. Positive (+) terminal protective cap
5. Battery spacer
6. ABS ground lead
7. Negative (-) lead
8. Negative (-) terminal

- ▼ Apply a light coat of grease to the terminals to prevent corrosion.
- ▼ Cover the positive terminal with the protective cap.

Daytona 660

- ▼ Position the battery into its housing.
- ▼ Insert the battery spacer.
- ▼ Install the battery strap.

NOTICE

The battery positive and negative leads are to be connected to the vertical face of the battery terminals.

- ▼ Reconnect the battery, positive (red) lead first and then the negative (black) lead.
- ▼ Tighten the battery terminals to 40 lbf in (4.5 Nm).

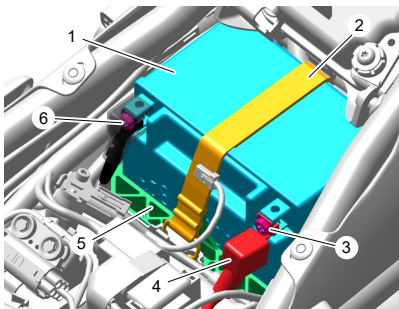

1. Battery
2. Battery strap
3. Positive (+) terminal
4. Positive (+) terminal protective cap
5. Battery spacer
6. Negative (-) terminal

- ▼ Apply a light coat of grease to the terminals to prevent corrosion.
- ▼ Cover the positive terminal with the protective cap.
- ▼ Install the seat, see page 117.

Fuses

⚠ WARNING

Always replace blown fuses with new ones of the correct rating (as specified on the fuse box cover).

Never replace a blown fuse with a fuse of a different rating.

Use of an incorrect fuse could lead to an electrical problem, resulting in motorcycle damage and leading to loss of motorcycle control, which could result in serious injury or death.

NOTICE

A blown fuse is indicated when all of the systems protected by that fuse become inoperative. When checking for a blown fuse, use the tables to establish which fuse has blown.

Fuse Box Locations

Trident 660 and Trident 660 - Triple Tribute

Fuse box 1 and the main fuse are located underneath the seat. To allow access to the fuse boxes, the seat must be removed (see page 116).

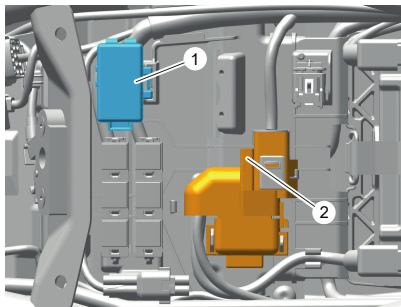

1. Fuse box 1
2. Main fuse (30 Amp)

Fuse box 2 is located under the plastic fuel tank cover.

Trident 800

Fuse box 1 and the main fuse are located underneath the seat. To allow access to the fuse boxes, the seat must be removed (see page 116).

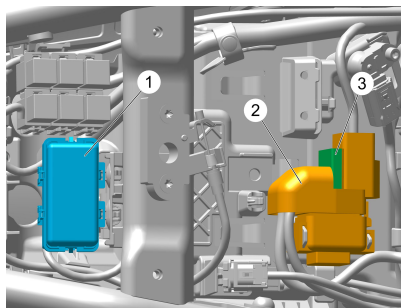

1. Fuse box 1
2. Starter motor relay
3. Main fuse (30 Amp)

NOTICE

The fuse box cover will only fit one way.

Do not force fit the fuse box cover.

To access the fuses, release the two retaining clips and remove the fuse box cover.

MAINTENANCE AND ADJUSTMENT

To access the spare fuses, release the retaining clip and open the lid on the fuse box cover.

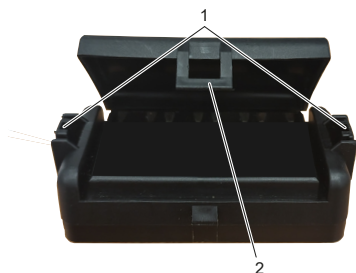

1. Fuse box cover retaining clips
2. Fuse box cover lid retaining clip

Tiger Sport 660, Tiger Sport 800 and Tiger Sport 800 Tour

The fuse boxes and the main fuse are located underneath the seat. To allow access to the fuse boxes, the seat must be removed (see page 116).

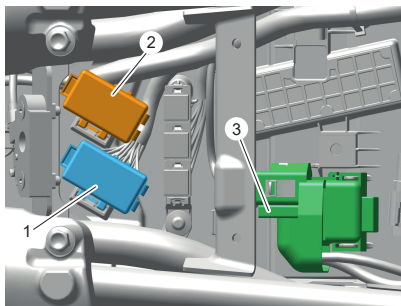

1. Fuse box 1
2. Fuse box 2
3. Main fuse (30 Amp)

Daytona 660

Fuse box 1 and the main fuse are located underneath the seat. To allow access to the fuse boxes, the seat must be removed (see page 116).

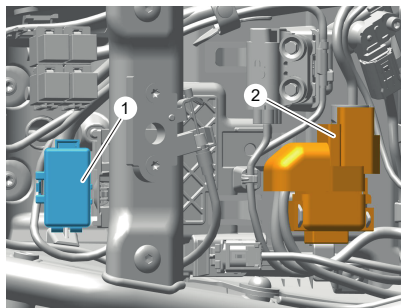

1. Fuse box 1
2. Main fuse (30 Amp)

Fuse box 2 is located under the left hand cockpit infill panel.

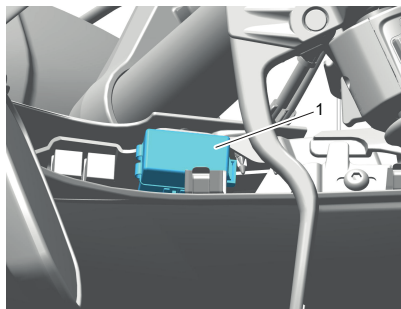

1. Fuse box 2

To remove the left hand cockpit infill panel:

- ▼ Slide the deflector fairing downwards to detach it from its retaining tang.

NOTICE

Note the position of the front end of the cockpit infill panel for installation.

- ▼ Remove the push release plastic rivet securing the cockpit infill panel to the fairing.
- ▼ Lift the lower edge of the cockpit infill panel to loosen it from its two retaining clips.
- ▼ Slide the cockpit infill panel rearwards for removal.

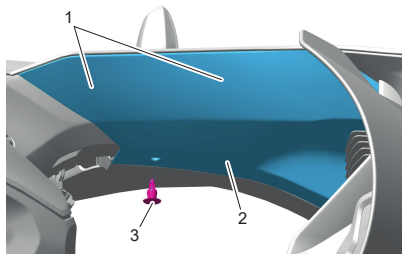

1. Retaining clips location
2. Cockpit infill panel
3. Push release plastic rivet

To install the left hand cockpit infill panel:

- ▼ Install the front end of cockpit infill panel as noted for removal and slide the lugs into the two retaining clips.
- ▼ Install the push release plastic rivet securing the cockpit infill panel to the fairing.

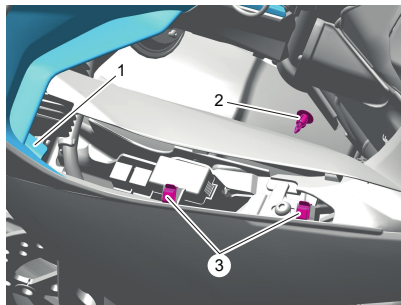

1. Cockpit infill panel locating feature
2. Push release plastic rivet
3. Retaining clips

MAINTENANCE AND ADJUSTMENT

Fuse Identification

The fuse identification numbers listed in the tables correspond with those printed on the fuse box covers, as shown below.

Spare fuses are located on the inside of the fuse box covers and should be replaced if used.

All Models

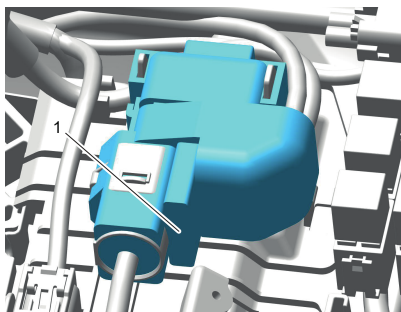

Main Fuse Box (Trident 660 shown)

Fuse Number and Circuit Protected	Rating (Amps)
Fuse 1 - Main fuse	30

Trident 660 and Trident 660 - Triple Tribute

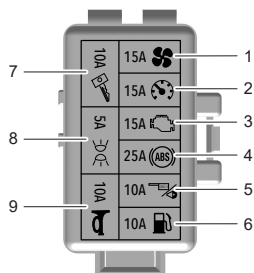

Fuse Box 1

Fuse Number and Circuit Protected	Rating (Amps)
Fuse 1 - Cooling fan	15
Fuse 2 - Instruments	15
Fuse 3 - Engine Management System (EMS)	15
Fuse 4 - ABS modulator	25
Fuse 5 - Diagnostics	10
Fuse 6 - Fuel pump	10
Fuse 7 - Ignition	10
Fuse 8 - Position light	5
Fuse 9 - Horn and main beam	10

Trident 800

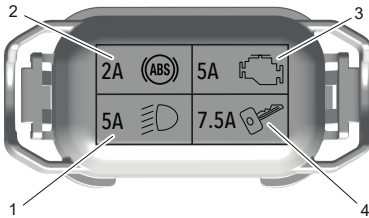

Fuse Box 2

Fuse Number and Circuit Protected	Rating (Amps)
Fuse 1 - Dipped beam	5
Fuse 2 - ABS	2
Fuse 3 - Engine Control Unit (ECU)	5
Fuse 4 - Ignition	7.5

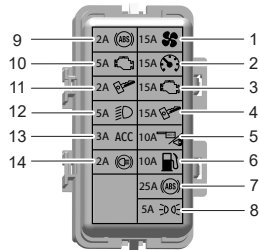

Fuse Number and Circuit Protected	Rating (Amps)
Fuse 1 - Cooling fan	15
Fuse 2 - Instruments	15
Fuse 3 - Engine Management System (EMS)	15
Fuse 4 - Ignition	15
Fuse 5 - Diagnostics	10
Fuse 6 - Fuel pump	10
Fuse 7 - ABS modulator	25
Fuse 8 - Position light	5
Fuse 9 - ABS Sensor	2
Fuse 10 - Engine Electronic Control Unit (ECM)	5
Fuse 11 - Ignition	2
Fuse 12 - Dipped beam	5
Fuse 13 - Accessory	3
Fuse 14 - Brake light	2

MAINTENANCE AND ADJUSTMENT

Tiger Sport 660

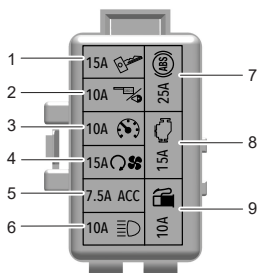

Fuse Box 1

Fuse Number and Circuit Protected	Rating (Amps)
Fuse 1 - Ignition	15
Fuse 2 - Diagnostics	10
Fuse 3 - Instruments	10
Fuse 4 - Starter motor and cooling fan	15
Fuse 5 - Accessories	7.5
Fuse 6 - Main beam	10
Fuse 7 - ABS	25
Fuse 8 - Engine Management System (EMS)	15
Fuse 9 - Fuel pump	10

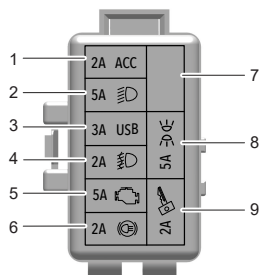

Fuse Box 2

Fuse Number and Circuit Protected	Rating (Amps)
Fuse 1 - Bluetooth	2
Fuse 2 - Dipped beam	5
Fuse 3 - USB	3
Fuse 4 - Fog lights	2
Fuse 5 - Engine Control Unit (ECU)	5
Fuse 6 - Brake light	2
Fuse 7 - Empty	-
Fuse 8 - Position light	5
Fuse 9 - Ignition	2

Tiger Sport 800 and Tiger Sport 800 Tour

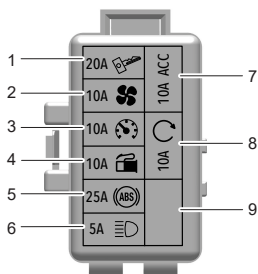

Fuse Box 1

Fuse Number and Circuit Protected	Rating (Amps)
Fuse 1 - Ignition	20
Fuse 2 - Cooling fan	10
Fuse 3 - Instruments	10
Fuse 4 - Fuel pump	10
Fuse 5 - ABS	25
Fuse 6 - Main beam	5
Fuse 7 - Accessories	10
Fuse 8 - Starter motor	10
Fuse 9 - Empty	-

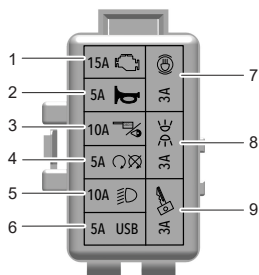

Fuse Box 2

Fuse Number and Circuit Protected	Rating (Amps)
Fuse 1 - Engine Management System (EMS)	15
Fuse 2 - Horn	5
Fuse 3 - Diagnostics	10
Fuse 4 - Start/stop switch	5
Fuse 5 - Dipped beam	10
Fuse 6 - USB	5
Fuse 7 - Brake light	3
Fuse 8 - Position light	3
Fuse 9 - Ignition	3

Daytona 660

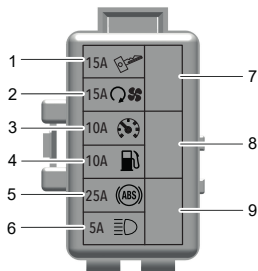

Fuse Box 1

Fuse Number and Circuit Protected	Rating (Amps)
Fuse 1 - Ignition	15
Fuse 2 - Starter motor and cooling fan	15
Fuse 3 - Instruments	10
Fuse 4 - Fuel pump	10
Fuse 5 - ABS	25
Fuse 6 - Main beam	5
Fuse 7 - Empty	-
Fuse 8 - Empty	-
Fuse 9 - Empty	-

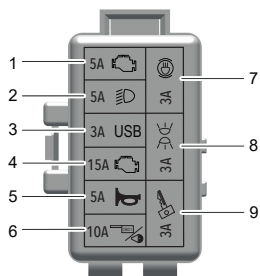

Fuse Box 2

Fuse Number and Circuit Protected	Rating (Amps)
Fuse 1 - Engine Control Unit (ECU)	5
Fuse 2 - Dipped beam	5
Fuse 3 - USB	3
Fuse 4 - Engine Management System (EMS)	15
Fuse 5 - Horn	5
Fuse 6 - Diagnostics	10
Fuse 7 - Brake light	3
Fuse 8 - Position light	3
Fuse 9 - Ignition	3

Lights

NOTICE

The use of non-approved LED light units may result in damage to the LED light unit and/or motorcycle.

Use genuine Triumph supplied LED light units, as specified in the Triumph Parts Catalog.

Always have replacement LED light units installed by a competent person with the specialist knowledge and technical understanding of motorcycles, such as an authorized Triumph dealer.

Headlight(s)



WARNING

Adjust road speed to suit the visibility and weather conditions in which the motorcycle is being operated.

Make sure that the headlight beam is adjusted to illuminate the road surface sufficiently far ahead, without blinding oncoming traffic.

An incorrectly adjusted headlight may impair visibility for oncoming traffic, leading to an accident, which could result in serious injury or death.

WARNING

Never attempt to adjust a headlight beam when the motorcycle is in motion.

Any attempt to adjust a headlight beam when the motorcycle is in motion may lead to loss of motorcycle control.

Failure to follow the advice above could result in serious injury or death.

NOTICE

Do not cover the headlight or lens with any item likely to obstruct air flow to, or prevent heat escaping from, the headlight lens. For example:

- Items of clothing or luggage
- Adhesive tape
- Devices intended to alter or adjust the headlight beam
- Non-genuine headlight lens covers.

Covering the headlight lens during operation will cause the headlight lens to overheat and distort, causing irreparable damage to the headlight assembly.

Damage caused by overheating is not considered a manufacturing defect and will not be covered under warranty.

If the headlight must be covered during use - such as taping of the headlight lens required during closed-course conditions - the headlight must be disconnected.

NOTICE

The use of non-approved headlight units may result in damage to the headlight unit and/or motorcycle.

Use a genuine Triumph supplied headlight unit, as specified in the Triumph Parts Catalog.

Always have replacement headlight units installed by a competent person with the specialist knowledge and technical understanding of motorcycles, such as an authorized Triumph dealer.

Condensation

NOTICE

If condensation inside the headlight does not clear, we recommend that the headlight is inspected by a competent person with the specialist knowledge and technical understanding of motorcycles, such as an authorized Triumph dealer.

In certain conditions, condensation may occur inside the headlight.

Condensation may happen while it is raining or after washing the motorcycle.

Condensation inside the headlight will gradually disappear with the headlight on while riding the motorcycle.

Time for evaporation will vary depending on the humidity of the ambient air.

Headlight(s) Adjustment

NOTICE

Check and, if necessary, correct the tire pressures before adjusting the headlight beam.

NOTICE

Always make sure the handlebars are in the straight ahead position when checking and adjusting the headlight beam.

Trident 660, and Trident 660 - Triple Tribute and Trident 800

The headlight can only be adjusted vertically.

- ▼ Switch the ignition on. The engine does not need to be running.
- ▼ Switch the headlight dipped beam on.
- ▼ Loosen the pivot bolt lock nut sufficiently to allow restricted movement of the headlight.
- ▼ Adjust the position of the headlight to give the required beam setting.
- ▼ Tighten the pivot bolt lock nut to 22 lbf ft (30 Nm).

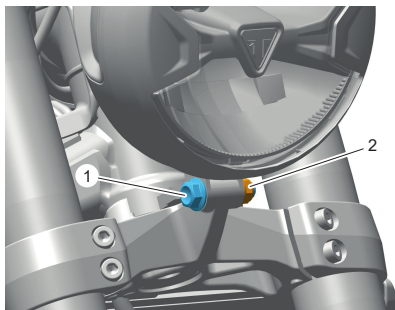

1. Headlight pivot bolt
2. Pivot bolt lock nut

- ▼ Recheck the headlight beam settings.

- ▼ Switch the headlights off when the beam settings are satisfactorily set.

Tiger Sport 660, Tiger Sport 800, Tiger Sport 800 Tour and Daytona 660

The left and right headlights can only be adjusted vertically and only adjusted together. Independent adjustment is not possible.

- ▼ Switch the ignition on. The engine does not need to be running.
- ▼ Switch the headlight dipped beam on.
- ▼ Using the Allen key provided under the seat, turn the headlight adjuster screw located underneath the cockpit to give the required beam setting.
- ▼ Standing in front of the motorcycle, turn the headlight adjuster screw clockwise to lower the headlight beam. Turn the headlight adjuster screw counterclockwise to raise the headlight beam.

- ▼ Use the small adjustment marker on each headlight unit as a guide to give the required headlight beam setting.

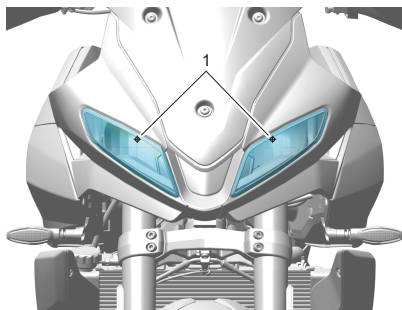

1. Headlight height adjustment markings (Tiger Sport 660 shown)

- ▼ Recheck the headlight beam settings.
- ▼ Switch the headlights off when the beam settings are satisfactorily set.

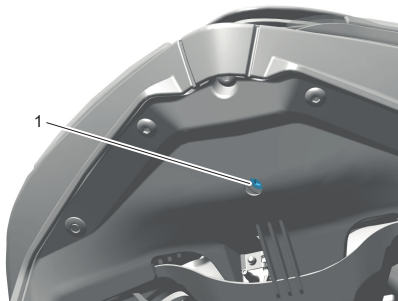

1. Headlight adjuster screw (Tiger Sport 660 shown)

MAINTENANCE AND ADJUSTMENT

Headlight(s) Replacement

The headlight unit is a sealed, maintenance-free LED unit. The headlight unit must be replaced in the event of the failure of the headlight.

Brake/Tail Light

The brake/tail light unit is a sealed, maintenance-free LED unit. The tail light unit must be replaced in the event of the failure of the tail light.

Turn Signal Lights

The turn signal light units are sealed, maintenance-free LED units. A turn signal light unit must be replaced in the event of the failure of the turn signal light.

License Plate Light

The license plate light unit is a sealed, maintenance-free LED unit. The license plate light unit must be replaced in the event of the failure of the license plate light.

Table of Contents

Cleaning.....	242
Preparation for Washing.....	242
Where to be Careful.....	243
Washing.....	244
After Washing.....	244
Gloss Paintwork Care.....	245
Matt Paintwork Care.....	245
Aluminum Items - not Lacquered or Painted.....	245
Chrome and Stainless Steel Care.....	246
Black Chrome Care.....	246
Exhaust System Care.....	247
Seat Care.....	248
Windshield Care (if equipped).....	248
Leather Products Care.....	249
Monsoon/Rainy Season Care.....	250
Storage.....	251

CLEANING AND STORAGE

Cleaning

Regular cleaning is an essential part of the maintenance of your motorcycle. If regularly cleaned, the appearance will be preserved for many years.

Cleaning with cold water containing an automotive cleaner is essential at all times, but particularly so after exposure to sea breezes, sea water, dusty or muddy roads and in winter, when roads are treated for ice and snow.

Do not use household detergent, as the use of such products will lead to premature corrosion.

Although, under the terms of your motorcycle warranty, cover is provided against the corrosion of certain items, the owner is expected to observe this reasonable advice, which will safeguard against corrosion and enhance the appearance of the motorcycle.

Preparation for Washing

Before washing, precautions must be taken to keep water off the following places.

Rear opening of the exhausts: Cover with a plastic bag secured with rubber bands.

Clutch and brake levers, switch housings on the handlebar: Cover with plastic bags.

Ignition switch and steering lock: Cover the keyhole (if applicable) with tape.

Remove any items of jewelry such as rings, watches, zips or belt buckles, which may scratch or otherwise damage painted or polished surfaces.

Use separate cleaning sponges or cleaning cloths for washing painted/polished surfaces and chassis areas. Chassis areas (such as wheels and under fenders) will be exposed to more abrasive road grime and dust, which may scratch painted or polished surfaces, if the same sponge or cleaning cloths are used.

Where to be Careful

NOTICE

Do not use high pressure spray washers or steam cleaners.

Use of high pressure spray washers and steam cleaners may damage seals, and cause water and steam to be forced into bearings and other components causing premature wear from corrosion and loss of lubrication.

NOTICE

Do not use compressed air to dry the motorcycle.

Use of compressed air may damage seals and cause water to be forced into bearings and other components causing premature wear from corrosion and loss of lubrication.

NOTICE

Do not spray any water at all near the air intake duct.

The air intake duct is located under the rider's seat, under the fuel tank or near the steering head.

Any water sprayed in this area could enter the airbox and engine, causing damage to both items.

Do not get water near the following places:

- ▼ Air and any intake duct
- ▼ Any visible electrical components
- ▼ Brake cylinders and brake calipers
- ▼ Handlebar switch housings
- ▼ Steering head bearings
- ▼ Instruments (if equipped)
- ▼ Oil filler cap
- ▼ Rear bevel box breather (if equipped)
- ▼ Rear of headlights (if equipped)
- ▼ Seats
- ▼ Suspension seals and bearings
- ▼ Steering damper (if equipped)
- ▼ Under the fuel tank
- ▼ Wheel bearings.

CLEANING AND STORAGE

Washing

To wash the motorcycle, do the following:

- ▼ Make sure that the motorcycle engine is cold.
- ▼ Prepare a mixture of clean, cold water and mild automotive cleaner or low alkaline soap.
- ▼ Do not use a highly alkaline soap as commonly found at commercial car washes because it will leave a residue on painted surfaces and may also cause water spotting.
- ▼ Wash the motorcycle with a sponge or soft cloth.
- ▼ Do not use abrasive scouring pads or steel wool. They will damage the finish.
- ▼ Rinse the motorcycle thoroughly with clean, cold water.

Do not use the following:

- ▼ Do not use high pressure spray washers or steam cleaners.
- ▼ Do not use compressed air to dry the motorcycle.

After Washing

WARNING

Never wax or lubricate the brake discs. Always clean the brake disc with a proprietary brand of oil-free brake disc cleaner.

Waxed or lubricated brake discs may lead to loss of motorcycle control which could result in serious injury or death.

After washing the motorcycle, do the following:

- ▼ Remove the plastic bags and tape, and clear the air intakes.
- ▼ Lubricate the pivots, bolts and nuts.
- ▼ Test the brakes before motorcycle operation.
- ▼ Use a dry cloth or chamois leather to absorb water residue. Do not allow water to stand on the motorcycle as this will lead to corrosion.
- ▼ Start the engine and run it for 5 minutes. Make sure that there is adequate ventilation for the exhaust fumes.

Gloss Paintwork Care

Gloss paintwork should be washed and dried as described previously, then protected using a high quality automotive wax polish. Always follow the manufacturer's instructions and repeat regularly to maintain your motorcycle's appearance.

Matt Paintwork Care

Matt paintwork requires no greater care than that already recommended for gloss paintwork. Note the following:

- ▼ Do not use any polish or wax on matt paintwork.
- ▼ Do not try and polish out scratches.

Aluminum Items - not Lacquered or Painted

Items such as brake and clutch levers, wheels, engine covers, engine cooling fins, upper and lower yokes and throttle bodies on some models must be correctly cleaned to preserve their appearance. Please contact your dealer if you are not sure which components on your motorcycle are aluminum parts not protected by paint or lacquer, and for guidance on how to clean those items.

Use a proprietary brand of aluminum cleaner that does not contain abrasive or caustic elements.

Clean aluminum items regularly, in particular after use in inclement weather, where the components must be hand washed and dried each time the machine is used.

Warranty claims due to inadequate maintenance will not be allowed.

CLEANING AND STORAGE

Chrome and Stainless Steel Care

All chrome and stainless steel parts of your motorcycle must be cleaned regularly to avoid a deterioration of its appearance.

Washing

Wash as previously described.

Drying

Dry the chrome and stainless steel parts as far as possible with a soft cloth or chamois leather.

Protecting

NOTICE

The use of products that contain silicone will cause discoloration of the chrome and stainless steel parts, and must not be used.

The use of abrasive cleaning products will damage the finish, and must not be used.

When the chrome and stainless steel is dry, apply a suitable proprietary chrome cleaner on to the surface, following the manufacturer's instructions.

It is recommended that regular protection be applied to the motorcycle as this will both protect and enhance its appearance.

Black Chrome Care

Items such as headlight bowls and mirrors on some models must be correctly cleaned to preserve their appearance. Please contact your dealer if you are not sure which components on your motorcycle are black chrome parts. Maintain the appearance of black chrome items by rubbing a small amount of light oil into the surface.

Exhaust System Care

All parts of the exhaust system of your motorcycle must be cleaned regularly to avoid a deterioration of its appearance. These instructions can be applied to chrome, brushed stainless steel and carbon fiber components. Matt painted exhaust systems should be cleaned as above, noting the care instructions in the Matt Paintwork section previously.

The exhaust system must be cool before washing to prevent water spotting.

Washing

Wash as previously described.

Make sure that no soap or water enters the exhausts.

Drying

Dry the exhaust system as far as possible with a soft cloth or chamois leather. Do not run the engine to dry the system or spotting will occur.

Protecting

NOTICE

The use of products that contain silicone will cause discoloration of the chrome and stainless steel parts, and must not be used.

The use of abrasive cleaning products will damage the finish, and must not be used.

When the exhaust system is dry, apply a suitable proprietary motorcycle protection spray onto the surface, following the manufacturer's instructions.

It is recommended that regular protection be applied to the system as this will both protect and enhance the system's appearance.

Seat Care**NOTICE**

Do not use chemicals or high pressure spray washers to clean the seat.

Using chemicals or high pressure spray washers may damage the seat cover.

To help maintain its appearance, clean the seat using a sponge or cleaning cloth with soap and water.

Windshield Care (if equipped)**WARNING**

Never attempt to clean the windshield while riding the motorcycle.

Removal of the rider's hands from the handlebars while riding the motorcycle will diminish the ability of the rider to maintain the control of the motorcycle.

Attempting to clean the windshield while riding the motorcycle may lead to loss of motorcycle control, which could result in serious injury or death.

NOTICE

Corrosive chemicals, such as battery acid, will damage the windshield. Never allow corrosive chemicals to come into contact with the windshield.

NOTICE

Products such as window cleaning fluids, insect remover, rain repellent, scouring compounds, gasoline or strong solvents such as alcohol, acetone, carbon tetrachloride, will damage the windshield.

Never allow these products to come into contact with the windshield.

Clean the windshield with a solution of mild soap or detergent and clean cold water.

After cleaning, rinse well and then dry with a soft, lint-free cloth.

If the transparency of the windshield is reduced by scratches or oxidation, which cannot be removed, the windshield must be replaced.

Leather Products Care

We recommend that the leather products are periodically cleaned with a damp cloth and allowed to dry naturally at room temperature. This will maintain the appearance of the leather and ensure the long life of the product.

The Triumph leather product is a natural product and lack of care can result in damage and permanent wear.

Follow these simple instructions to prolong the life of the leather product:

- ▼ Do not use household cleaning products, bleach, detergents containing bleach or any kind of solvent to clean the leather product.
- ▼ Do not immerse the leather product in water.
- ▼ Avoid direct heat from fires and radiators, which can dry out and distort the leather.
- ▼ Do not leave the leather product in direct sunlight for prolonged periods of time.
- ▼ Do not dry the leather product by applying direct heat to it at any time.

CLEANING AND STORAGE

- ▼ If the leather product does get wet, absorb any excess water with a soft, clean cloth then leave the leather product to dry naturally at room temperature.
- ▼ Avoid exposure of the leather product to high levels of salt, for example sea/salt water or road surfaces that have been treated during the winter for ice and snow.
- ▼ If exposure to salt is unavoidable, clean the leather product immediately after each exposure using a damp cloth, then leave the leather product to dry naturally at room temperature.
- ▼ Gently clean any minor marks with a damp cloth then leave the leather product to dry naturally at room temperature.
- ▼ Place the leather product in a fabric bag or cardboard box to protect it when in storage. Do not use a plastic bag.

Monsoon/Rainy Season Care

During the Monsoon/Rainy season, extra care is required in order to obtain consistent performance of your motorcycle.

Always observe the following:

- ▼ Make sure that the motorcycle is parked in a covered area. If a covered area is not available, make sure to put a suitable waterproof breathable cover over the motorcycle.
- ▼ Make sure that the tires are in a good condition.
- ▼ Check and, if necessary, correct the tire pressures.

NOTICE

If the drive chain gets contaminated by mud, we recommend that the drive chain is cleaned and lubricated before riding.

- ▼ The drive chain should be cleaned and lubricated every 200 miles (300 km) using Triumph Performance chain lubricant.

WARNING

When using the motorcycle on loose, wet or muddy roads, braking effectiveness will be reduced by dust, mud or moisture collecting on the brakes.

Always brake earlier in these conditions to make sure that brake surfaces are cleaned by the braking action.

Riding the motorcycle with brakes contaminated with dust, mud or moisture may lead to loss of motorcycle control, which could result in serious injury or death.

- ▼ Check that the front and rear brakes are functioning correctly.
- ▼ Make sure that you wear appropriate waterproof clothing suitable for motorcycles.
- ▼ Never ride the motorcycle through floods as water may enter the engine. Water entering the engine may cause engine damage. Damage caused by water entering the engine is not covered by the motorcycle warranty, as it is not due to a manufacturing defect.
- ▼ If the motorcycle is parked and water level rises around the motorcycle, do not try to start the engine. The motorcycle should be inspected for water ingress before starting the engine. Inspections and repairs must be completed by a competent person with the specialist knowledge and technical understanding of motorcycles, such as an authorized Triumph dealer.

Storage

Preparation for Storage

To prepare the motorcycle for storage, do the following:

- ▼ Clean and dry the entire vehicle thoroughly.
- ▼ Fill the fuel tank with the correct grade of unleaded fuel and add a suitable fuel stabilizer (if available), following the fuel stabilizer manufacturer's instructions.

WARNING

Gasoline is extremely flammable and can be explosive under certain conditions.

If parking inside a garage or other structure, be sure it is well ventilated and the motorcycle is not close to any source of flame or sparks. This includes any appliance with a pilot light.

Failure to follow the above advice may cause a fire resulting in damage to property, serious injury or death.

- ▼ Remove the spark plug from each cylinder and put several drops (0.17 fl oz (5 cc)) of engine oil into each cylinder. Cover the spark plug holes with a piece of cloth or rag. With the engine stop switch in the RUN position, push the starter button for a few seconds to coat the cylinder walls with oil. Install the spark plugs, tightening to 9 lbf ft (12 Nm).
- ▼ Change the engine oil and filter (see page 178).
- ▼ Check and if necessary correct the tire pressures (see page 267).

CLEANING AND STORAGE

- ▼ Set the motorcycle on a stand so that both wheels are raised off the ground. (If this cannot be done, put boards under the front and rear wheels to keep dampness away from the tires).
- ▼ Spray rust inhibiting oil (there are numerous products on the market and your dealer will be able to offer you local advice) on all unpainted metal surfaces to prevent rusting. Prevent oil from getting on rubber parts, brake discs or in the brake calipers.
- ▼ Lubricate and if necessary adjust the drive chain (see page 188).
- ▼ Make sure the cooling system is filled with a 50% mixture of coolant (noting that D2053 OAT coolant, as supplied by Triumph, is premixed and requires no dilution) and distilled water solution (see page 181).
- ▼ Remove the battery, and store it where it will not be exposed to direct sunlight, moisture, or freezing temperatures. During storage it should be given a slow charge (one Ampere or less) about once every two weeks (see page 225).
- ▼ Store the motorcycle in a cool, dry area, away from sunlight, and with a minimum daily temperature variation.
- ▼ Put a suitable porous cover over the motorcycle to keep dust and dirt from collecting on it. Avoid using plastic or similar non-breathable, coated materials that restrict air flow and allow heat and moisture to accumulate.

Preparation after Storage

To prepare the motorcycle to be ridden after storage, do the following:

- ▼ Install the battery (if removed) (see page 226).
- ▼ If the motorcycle has been stored for more than four months, change the engine oil (see page 178).
- ▼ Check all the points listed in the Daily Safety Checks section.
- ▼ Before starting the engine, remove the spark plugs from each cylinder.
- ▼ Put the side stand down.
- ▼ Crank the engine on the starter motor several times until the oil pressure light goes out.
- ▼ Install the spark plugs, tightening to 9 lbf ft (12 Nm), and start the engine.
- ▼ Check and if necessary correct the tire pressures (see page 267).
- ▼ Check and if necessary adjust the drive chain tension (see page 190).
- ▼ Clean the entire vehicle thoroughly.
- ▼ Check the brakes for correct operation.
- ▼ Test ride the motorcycle at low speeds.

Table of Contents

Triumph Warranty Terms and Conditions - America and Canada only	254
Conditions and Exclusions - America and Canada only	255
Noise Control System Warranty	257
Tampering With The Noise Control System Prohibited.....	258
Emission Control System Warranty.....	259
California Emissions Control Warranty Statement	260
Manufacturer's Warranty Coverage.....	261
Owner's Warranty Responsibility	261
What is Covered by this Emission Warranty	263
What Is Not Covered By This Emission Warranty.....	264
Triumph Overseas.....	264
Caring for your Motorcycle.....	265

WARRANTY

Triumph Warranty Terms and Conditions - America and Canada only

Thank you for choosing a Triumph motorcycle. This motorcycle is the product of Triumph's use of proven engineering, exhaustive testing, and continuous striving for superior reliability, safety, and performance.

This section of the Owner's Handbook includes details of the warranty and other useful information concerning your motorcycle.

Make sure that all your owner information is entered in the Triumph Motorcycle Service Handbook that is provided with the motorcycle.

Maintain maximum protection under warranty by making sure that your motorcycle is serviced in accordance with the recommendations of the scheduled maintenance chart in this Owner's Handbook.

If you should sell your motorcycle, make sure this Owner's Handbook or Quick Start Guide (where supplied with the motorcycle) together with all other relevant documents are passed to the new owner. Please advise the new owner that they can notify Triumph of the change of ownership by contacting their local Triumph dealer.

All new Triumph motorcycles are covered by a comprehensive unlimited mileage warranty, commencing from the date of first registration or the date of sale if the motorcycle remains unregistered. Refer to your motorcycle warranty registration certificate for details of the warranty period.

Within the warranty period, TRIUMPH MOTORCYCLES AMERICA LIMITED warrant the new Triumph motorcycle detailed in the Motorcycle Service Handbook to be free from any defect in materials used in the manufacture, and/or workmanship at the time of its manufacture.

Any part found to be defective during this period will be repaired or replaced at the discretion of TRIUMPH MOTORCYCLES AMERICA LIMITED by an authorized Triumph dealer.

Any part replaced under the warranty will be covered for the remaining period of the warranty.

Any parts replaced under warranty must be returned to TRIUMPH MOTORCYCLES AMERICA LIMITED by the dealer/distributor and will become the property of Triumph Motorcycles America Ltd.

Triumph may, at its discretion make any repairs or replacement of defective parts falling outside the warranty, but such work shall not be deemed to be any admission of liability.

Triumph will bear labor charges for work carried out under the warranty.

The warranty may be transferred to subsequent owners for the balance of the remaining warranty period.

Conditions and Exclusions - America and Canada only

- ▼ The motorcycle must not have been used for competition, misused¹, inadequately or incorrectly serviced or maintained.
- ▼ The motorcycle must have been serviced as detailed in the manufacturers service maintenance schedule, at the intervals specified in the Owner's Handbook and the service log completed accordingly.
- ▼ The motorcycle battery is warranted for 12 (twelve) months from the original date of purchase of the motorcycle. After this 12 (twelve) month period, the battery is excluded from the terms of this warranty. The battery supplied with the motorcycle must be provided with sufficient charge to replenish that lost by the operation of the starting mechanism and/or the use of electrical equipment while the engine is not running.

Refer to the battery section of this handbook for details of required battery maintenance.

The warranty does not cover:

- ▼ Defects caused by incorrect adjustment, repair or modification not authorized by TRIUMPH MOTORCYCLES AMERICA LIMITED.

¹ Misuse includes any use not in accordance with the recommendations made in the 'how to ride the motorcycle' section of the Owner's Handbook and any use contrary to the warnings given in that same handbook. In addition, misuse will include, but not be limited to any use of the motorcycle which does not constitute normal use.

WARRANTY

- ▼ Defects caused by the use of parts and accessories not authorized by TRIUMPH MOTORCYCLES AMERICA LIMITED.
- ▼ The cost of removal and replacement of parts and accessories, unless supplied as original equipment, or recommended by TRIUMPH MOTORCYCLES AMERICA LIMITED.
- ▼ The cost of transportation of the motorcycle to or from the authorized Triumph dealer, or expenses incurred while the motorcycle is unable to be ridden due to warranty repairs.
- ▼ Normal servicing and normal service items, such as spark plugs, oil and air filters are not covered by this warranty. Similarly, items which are expected to wear as part of their normal function such as tires, bulbs, chains, brake pads and clutch plates are also excluded, unless there is a manufacturing defect.
- ▼ Defects to the front fork oil seals as they are subject to wear and tear, including but not limited to damage caused by stone chips to the inner fork tubes.
- ▼ Seats, luggage, paint, chrome, polished aluminum items, or trim deterioration or fading caused by normal wear and tear, exposure, or lack of correct maintenance.
- ▼ Motorcycles used on a commercial basis.
- ▼ Defects which have not been reported to an authorized dealer within ten days of discovery of the defect.
- ▼ Motorcycles which have been inadequately lubricated, or for which the wrong fuel or lubricant has been used.
- ▼ Damages due to water submersion and/or foreign material ingestion.

Should a warranty claim become necessary, Triumph Motorcycles and its authorized dealers shall not be liable for loss of use, inconvenience, lost time, commercial losses or other incidental or consequential damages.

This warranty shall be governed by and construed in accordance with the laws of England and Wales, save that in the event of any material conflict or inconsistency between such application to this warranty of the laws of England and Wales and local statutory rights that would otherwise be applicable to Triumph customers (dealerships or consumers) purchasing Triumph products in another country, those local statutory rights shall take precedence.

The competent courts of England and Wales shall have primary authority to settle any questions, claims or disputes which may arise under or in connection with this warranty, save that to the extent that any such issue arising requires the consideration and interpretation of applicable local statutory rights applicable to a customer purchasing Triumph products in another country, the customer may seek to take proceedings in any competent court of that country.

Any statement, condition, representation, description, or warranty otherwise contained in any catalog, advertisement or other publication shall not be construed as enlarging, varying or overriding anything contained herein.

Triumph Motorcycles reserve the right to make alterations or improvements without notification to any model or motorcycle without obligation to do so to motorcycles already sold.

This warranty does not affect your statutory rights.

Noise Control System Warranty

NOTICE

This product should be checked for repair or replacement if the motorcycle noise has increased significantly through use, otherwise the owner may become subject to penalties under state and local ordinances.

The following warranty applies to the noise control system and is in addition to the general Triumph warranty and the emission control warranty.

Per 40 C.F.R. § 205.173-1, Triumph Motorcycles America Limited, warrants that this exhaust system, at the time of sale, meets all applicable U.S. E.P.A. federal noise standards. This warranty extends to the first person who buys this exhaust system for purposes other than resale, and to all subsequent buyers. Warranty claims should be directed to an authorized Triumph Motorcycles America dealer.

Triumph Motorcycles America Limited warrants to the first, and each subsequent owner, that the vehicle was designed and built so as to conform, at the time of sale, with the regulations of the U.S. Environmental Protection Agency (as tested following F-76 Drive-By test procedure) and, at the time of manufacture, was free from defects in materials and workmanship which would cause the motorcycle not to meet the U.S. Environmental Protection Agency Standards. This noise control system warranty extends for a period of 1 calendar year or 3,730 miles (6,000 km) whichever occurs first from the date on which the motorcycle was delivered to the first retail purchaser or, in the case of a demonstration motorcycle or company motorcycle, the date on which the company placed the motorcycle in service prior to retail sale.

Tampering With The Noise Control System Prohibited

Owners are warned that the law prohibits:

- (a) The removal or rendering inoperative by any person other than for purposes of maintenance, repair or replacement, of any device or element of design incorporated into any new vehicle for the purpose of noise control prior to its sale or delivery to the ultimate purchaser or while it is in use and
- (b) the use of the vehicle after such device or element of design has been removed or rendered inoperative by any person.

Acts which are likely to constitute tampering include the following:

- ▼ Removal or tampering with the mufflers, baffles or header pipes or any other component which conducts exhaust gases.
- ▼ Removal of or puncturing of any part of the air intake system.
- ▼ Failure to carry out maintenance as prescribed in the owner's manual.

- ▼ Replacement of any parts of the exhaust or air intake system with parts other than those specified by Triumph Motorcycles America Limited.

The following items are not covered by the noise control system warranty:

- ▼ Failures which arise through misuse, alterations or accident damage.
- ▼ Replacing, removing, or modifications of any part of the noise control system (consisting of the exhaust system and air intake system) with parts not certified to be noise legal for street use.
- ▼ Triumph Motorcycles America Limited and its authorized dealers shall not be liable for loss of use, inconvenience, lost time, commercial losses or other incidental or consequential damages.
- ▼ Any motorcycle which has had the odometer recorded mileage changed so that the correct mileage of the motorcycle cannot be accurately determined.

Emission Control System Warranty

The following warranty applies to the emission control system and is in addition to the general Triumph warranty and the noise control system warranty.

Triumph Motorcycles America Limited warrants to the first, and each subsequent owner, that the vehicle was designed and built so as to conform, at the time of sale, with the regulations of the U.S. Environmental Protection Agency and the California Air Resources Board and, at the time of manufacture, was free from defects in materials and workmanship which would cause the motorcycle not to meet the U.S. Environmental Protection Agency or California Air Resources Board Standards. This emission control system warranty extends for a period of 5 calendar years or 18,641 miles whichever occurs first, from the date on which the motorcycle was delivered to the first retail purchaser or, in the case of a demonstration motorcycle or company motorcycle, the date on which the company placed the motorcycle in service prior to retail sale.

WARRANTY

The following are not covered by the emission control system warranty:

- ▼ Failures which arise through misuse, alterations, accident damage or failure to carry out maintenance as described in the owner's manual.
- ▼ The replacement of any parts required in the maintenance of the emission control system.
- ▼ Triumph Motorcycles America Limited and its authorized dealers shall not be liable for loss of use, inconvenience, lost time, commercial losses or other incidental or consequential damages.
- ▼ Any motorcycle which has had the odometer recorded mileage changed so that the correct mileage of the motorcycle cannot be accurately determined.

California Emissions Control Warranty Statement

Your warranty rights and obligations

The California Air Resources Board and Triumph Motorcycles America Limited are pleased to explain the emission control system on your motorcycle. In California, new motor vehicles must be designed, built and equipped to meet the State's stringent anti-smog standards. Triumph Motorcycles America Limited must warrant the emission control system on your motorcycle for the periods of time listed below provided there has been no abuse, neglect or improper maintenance of your vehicle.

Your emission control system may include parts such as the fuel injection and the ignition systems. Also included may be hoses, connectors and other emission related assemblies.

Where a warrantable condition exists, Triumph Motorcycles America Limited will repair your motorcycle at no cost to you including diagnosis, parts and labor.

Manufacturer's Warranty Coverage

For a period of use of five years or 18,641 miles, whichever first occurs: If an emission related part on your motorcycle is defective, the parts will be repaired or replaced by Triumph Motorcycles America Limited. This is your emission control system DEFECTS WARRANTY.

Owner's Warranty Responsibility

As the motorcycle owner, you are responsible for the performance of the required maintenance listed in your owner's manual.

Triumph Motorcycles America Limited recommends that you retain all receipts covering maintenance on your motorcycle, but Triumph Motorcycles America Limited cannot deny warranty solely for the lack of receipts or for your failure to ensure the performance of all scheduled maintenance.

You are responsible for presenting your motorcycle to a Triumph Motorcycles America Limited dealer as soon as a problem exists. The warranty repairs should be completed in a reasonable amount of time, not to exceed 30 days.

As the motorcycle owner, you should also be aware that Triumph Motorcycles America Limited may deny you warranty coverage if your motorcycle or a part has failed due to abuse, neglect, improper maintenance or unapproved modifications.

If you have any questions regarding your warranty rights and responsibilities, you should contact Triumph Motorcycles America Limited, Warranty Service Department, 1070 White Street SW, Suite B, Atlanta, GA 30310 (telephone 678 854 2010), or the California Air Resources Board at 4001 Iowa Avenue, Riverside, California 92507.

WARRANTY

Triumph Motorcycles America Limited warrants to the first, and each subsequent owner, that the vehicle was designed and built so as to conform, at the time of sale, with the regulations of the California Air Resources Board and, at the time of manufacture, was free from defects in materials and workmanship which would cause the motorcycle not to meet the California Air Resources Board Standards.

This warranty period starts the date the motorcycle is delivered to the first retail purchaser or, if the motorcycle is placed in service as a demonstrator or company motorcycle prior to sale at retail, the date it is first placed in service.

The emission control system of each new Triumph motorcycle was designed, built and tested using only genuine Triumph Motorcycle parts and with these parts the motorcycle is certified as being in conformity with California emission control regulations.

WE RECOMMEND THAT ONLY GENUINE TRIUMPH MOTORCYCLE PARTS BE USED FOR MAINTENANCE REPAIR OR REPLACEMENT OF THE EMISSION CONTROL SYSTEM. However, if you are willing to pay for it yourself, you can have replacement or repair of your motorcycle's emission control system performed by any qualified repair establishment or individual using non-genuine parts.

Remember: Use of replacement parts which are not equal in quality to genuine Triumph parts may impair the effectiveness of the emission control system or otherwise damage your motorcycle. If other than genuine Triumph parts are used for maintenance, replacement or repair of components affecting emission control, you should obtain written assurances that such non-Triumph parts are warranted by their manufacturer to be equal in quality to genuine Triumph Motorcycle parts in both performance and durability. The use of non-Triumph replacement parts does not invalidate the warranty, if any, on other components unless the non-Triumph parts cause damage to warranted parts. However, we recommend that you go only to any authorized Triumph Motorcycle dealer for repairs under warranty, that has factory-trained mechanics and genuine parts. However, in the case of an "emergency" (as defined below) where an authorized Triumph dealer is not reasonably available, you could have repairs performed at any available service establishment or by the owner, using any replacement part. A part not being available within 30 days, or a repair not being complete within 30 days constitutes an emergency. Triumph Motorcycles America Limited will reimburse the owner for such repairs, including diagnosis, only if it is established that the repairs are covered under this emission warranty. Triumph Motorcycles America Limited parts reimbursement, however, will not exceed our suggested retail price for all

warranted parts replaced and our labor reimbursement will be limited to our recommended time allowances for emission system repairs at the geographically appropriate hourly labor rate.

To obtain reimbursement from Triumph Motorcycles America Limited for such emergency repairs, you must keep all failed parts and original receipts, marked "paid," so you can present them to an authorized Triumph dealer for their inspection. Triumph Motorcycles America Limited recommends that you bring your motorcycle to an authorized dealer for inspection to ensure that the emergency repairs were done properly.

What is Covered by this Emission Warranty

The emission control system warranty covers the following "warranted parts" only:

- ▼ Fuel injection/engine management equipment including oxygen sensors
- ▼ Intake manifold
- ▼ Air cleaner box
- ▼ Spark advance/retard system
- ▼ Spark plugs (first 10,000 miles)
- ▼ Ignition coils
- ▼ Charcoal canister
- ▼ Cap, fuel tank
- ▼ Fuel/vapor separator (fuel tank)
- ▼ Vapor valve
- ▼ Catalyst (including parts containing a catalyst)
- ▼ Rollover/vent/pressure control valves
- ▼ Secondary air system
- ▼ If used on the above systems: hoses, clamps, fittings, tubing, sealing gaskets and mounting hardware.

WARRANTY

What Is Not Covered By This Emission Warranty

The emission control system warranty does not cover:

Malfunctions in any "warranted parts" caused by any of the following: abuse, misuse, modification, alteration, tampering, disconnection, or improper or inadequate maintenance.

Damage resulting from accident, acts of nature or other events beyond the control of Triumph Motorcycles America Limited.

The repair or replacement of "warranted parts" which are scheduled for replacement prior to 18,641 miles (such as spark plugs, which are scheduled for replacement at 10,000 miles) once these parts have been replaced at the first replacement interval as part of required maintenance services.

Repairs and services performed by anyone other than an authorized Triumph dealer (except in case of emergency). The California Air Resources Board defines an "emergency" as an authorized dealer not being reasonably available or the lack of availability of "warranted parts" within a reasonable time period not to exceed 30 days.

Loss of time, inconvenience, loss of use of the motorcycle, or commercial loss.

Repairs on any motorcycle of which odometer mileage has been changed so that mileage cannot be really determined.

Triumph Overseas

If you are traveling abroad and require assistance or advice from a Triumph dealer, contact the subsidiary or importer for the country which you are visiting.

Subsidiary offices are listed below.

For an up to date list of authorized Triumph dealers and importers, visit www.triumphmotorcycles.co.uk/dealers.

Subsidiary Offices

Benelux

Triumph Netherlands

Tel: +31 725 41 0311

Email: Benelux@Triumph.co.uk

Brazil

Triumph Motorcycles Brazil Ltda

Tel: +55 11 3010 1010

Email: sac.triumph@europ-assistance.com.br

China

British Triumph (Shanghai) Trading Co., Ltd.

Tel: +86 21 6140 9180

Email: aftersales.china@triumphmotorcycles.com

Denmark/Finland/Norway/Sweden

Triumph Motorcycles AB

Tel: +46 8 680 68 00

Fax: +46 8 680 07 85

France

Triumph S.A.

Tel: +33 1 64 62 3838

Fax: +33 1 64 80 5828

Germany/Austria

Triumph Motorrad Deutschland GmbH

Tel: +49 6003 829090

Fax: +49 6003 8290927

Italy

Triumph Motorcycles srl

Tel: +39 02 93 454525

Fax: +39 02 93 582575

Japan

Triumph Motorcycles Japan K.K.

Tel: +81 3 6453 9810

Fax: +81 3 6453 9811

Spain/Portugal

Triumph Motocicletas España, S.L

Tel: +34 91 637 7475

Fax: +34 91 636 1134

Thailand

Triumph Thailand

Tel: +66(0)20170333

Fax: +66(0)20170330

United Kingdom/Éire

Triumph Motorcycles Ltd

Tel: +44 1455 45 5012

Fax: +44 1455 45 2211

USA/Canada

Triumph Motorcycles (America) Ltd

Tel: +1 678 854 2010

Fax: +1 678 854 8740

Caring for your Motorcycle

Triumph Motorcycles have taken great care in the selection of materials, plating and painting techniques so as to provide its customers with a quality cosmetic appearance allied to durability. However, motorcycles are often used in hostile environmental conditions and in these circumstances it is essential that the motorcycle is washed, dried and lost lubricity replaced to prevent discoloration particularly of plated and unplated metallic surfaces. Your dealer can provide further information and advice if required. Ultimately the appearance of your motorcycle will very much depend on the care it receives.

For further information in regards to caring for your motorcycle, refer to the Cleaning and Storage section of this Owner's Handbook.

This page intentionally left blank

Table of Contents

Trident 660 and Trident 660 - Triple Tribute.....	268
Trident 800	273
Tiger Sport 660.....	278
Tiger Sport 800.....	283
Daytona 660.....	288
Tiger Sport 800 Tour.....	293

SPECIFICATIONS

Trident 660 and Trident 660 - Triple Tribute

Dimensions, Weights and Performance

A list of model specific dimensions, weights and performance figures is available from your authorized Triumph dealer, or on the Internet at www.triumphmotorcycles.co.uk.

Payload

Trident 660 and Trident 660 - Triple Tribute

Maximum payload (rider, passenger, luggage and accessories)

452 lb (205 kg)

Engine

Trident 660 and Trident 660 - Triple Tribute

Engine configuration

3 cylinder 12 valve DOHC

Arrangement

Transverse in-line

Displacement

40.3 cu in (660 cc)

Bore x stroke

2.91 x 2.01 in (74 x 51.1 mm)

Compression ratio

11.95:1

Cylinder numbering

Left to right (no.3 adjacent to camshaft drive)

Cylinder sequence

Number 1 at left

Firing order

1 2 3

Starting system

Electric starter

Lubrication

Trident 660 and Trident 660 - Triple Tribute

Lubrication system

Pressure lubrication, wet sump

Engine Oil Capacities:

Oil capacity (dry fill)

0.85 gallons (3.20 liters)

Oil capacity (wet fill including oil filter)

0.74 gallons (2.80 liters)

Oil capacity (wet fill excluding oil filter)

0.69 gallons (2.60 liters)

Cooling System	Trident 660 and Trident 660 - Triple Tribute
Coolant type	Triumph D2053 OAT coolant (premixed)
Coolant ratio	50/50 (premixed as supplied by Triumph)
Cooling system capacity	0.58 gallons (2.2 liters)
Thermostat opening temperature (nominal)	159.8°F +/- 4°F (71°C +/- 2°C)

Fuel System	Trident 660 and Trident 660 - Triple Tribute
Fuel injection system	Electronic, sequential
Injector type	Twin jet, solenoid operated plate valve
Fuel pump type	Submerged electric
Fuel pressure (nominal)	50.8 lb/in ² (3.5 bar)

Fuel	Trident 660 and Trident 660 - Triple Tribute
Fuel type	Unleaded, 91 RON (U.S. 87 CLC/AKI)
Fuel tank capacity	3.7 gallons (14.0 liters)
Low fuel indicator light	0.82 gallons (3.1 liters)

Ignition	Trident 660 and Trident 660 - Triple Tribute
Ignition system	Digital inductive
Electronic rev. limiter	10,500 rpm
Spark plug type	NGK CR9EK
Spark plug gap	0.02 - 0.03 in (0.60-0.75 mm)

SPECIFICATIONS

Transmission	Trident 660 and Trident 660 - Triple Tribute
Transmission type	6 speed, constant mesh
Clutch type	Wet multi-plate, slip assist
Chain type	DID520VM4
Number of links	120
Chain length (20 links)	12.56 in (319 mm)
Primary drive ratio	1.854:1 (76/41)
Final drive ratio	3.188:1 (51/16)
Gear ratios - 1st gear	2.867:1 (43/15)
Gear ratios - 2nd gear	2.053:1 (39/19)
Gear ratios - 3rd gear	1.565:1 (36/23)
Gear ratios - 4th gear	1.286:1 (27/21)
Gear ratios - 5th gear	1.107:1 (31/28)
Gear ratios - 6th gear	0.967:1 (29/30)

WARNING

Use the recommended tires **ONLY** in the combinations listed in the approved Tire Selector at www.triumphtechnicalinformation.com/tyres.

Do not mix tires from different manufacturers or mix different specification tires from the same manufacturers.

Using/mixing tires may affect the handling, stability, braking and traction control (if equipped) functions of the motorcycle.

Failure to follow the advice above may lead to loss of motorcycle control, which could result in serious injury or death.

Approved Tires

A list of approved tires specific to these models is available from your authorized Triumph dealer, or on the Internet at www.triumphtechnicalinformation.com/tyres.

Tires		Trident 660 and Trident 660 - Triple Tribute
Tire Sizes:		
Front tire size		120/70 ZR17 58W
Rear tire size		180/55 ZR17 73W
Tire Pressures (Cold):		
Front tire pressure		34 lb/in ² (2.34 bar)
Rear tire pressure		42 lb/in ² (2.90 bar)

Electrical Equipment		Trident 660 and Trident 660 - Triple Tribute
Battery type		YTX9-BS
Battery rating		12 Volt - 8 Ah
Alternator rating		14 Volt, 29 Amp at 5,000 rpm
Parking light		LED
Headlight		LED
Rear/brake light		LED
License plate light		LED
Turn signal lights		LED

SPECIFICATIONS

Torque Figures	Trident 660 and Trident 660 - Triple Tribute
Battery terminal fasteners	40 lbf in (4.5 Nm)
Drive chain slack adjuster lock nut	12 lbf ft (16 Nm)
Rear hugger and chain guard molding	35 lbf in (4 Nm)
Clutch cable lower lock nut	27 lbf in (3 Nm)
Oil filter	89 lbf in (10 Nm)
Spark plug	9 lbf ft (12 Nm)
Sump plug	18 lbf ft (25 Nm)
Rear wheel spindle lock nut	81 lbf ft (110 Nm)

Fluids and Lubricants	Trident 660 and Trident 660 - Triple Tribute
Bearings and pivots	Triumph Performance RG2 grease (NLGI 2)
Brake fluid	Triumph Performance DOT 4 brake fluid
Coolant	Triumph D2053 OAT coolant (premixed)
Drive chain	Triumph Performance chain lubricant
Engine oil	Fully or semi-synthetic 10W/40 or 10W/50 motorcycle engine oil that meets specification API SN (or higher) and JASO MA2. Triumph Performance fully synthetic engine oil is recommended

Trident 800

Dimensions, Weights and Performance

A list of model specific dimensions, weights and performance figures is available from your authorized Triumph dealer, or on the Internet at www.triumphmotorcycles.co.uk.

Payload

Trident 800

Maximum payload (rider, passenger, luggage and accessories)

463 lb (210 kg)

Engine

Trident 800

Engine configuration

3 cylinder 12 valve DOHC

Arrangement

Transverse in-line

Displacement

48.7 cu in (798 cc)

Bore x stroke

3.07 x 2.19 in (78 x 55.65 mm)

Compression ratio

13.23:1

Cylinder numbering

Left to right (no.3 adjacent to camshaft drive)

Cylinder sequence

Number 1 at left

Firing order

1 2 3

Starting system

Electric starter

SPECIFICATIONS

Lubrication		Trident 800
Lubrication system		Pressure lubrication, wet sump
Engine Oil Capacities:		
Oil capacity (dry fill)		0.9 gallons (3.40 liters)
Oil capacity (wet fill including oil filter)		0.79 gallons (3.00 liters)
Oil capacity (wet fill excluding oil filter)		0.74 gallons (2.80 liters)
Cooling System		Trident 800
Coolant type		Triumph D2053 OAT coolant (premixed)
Coolant ratio		50/50 (premixed as supplied by Triumph)
Cooling system capacity		0.69 gallons (2.60 liters)
Thermostat opening temperature		159.8°F +/- 4°F (71°C +/- 2°C)
Fuel System		Trident 800
Fuel injection system		Electronic, sequential
Injector type		Twin jet, solenoid operated plate valve
Fuel pump type		Submerged electric
Fuel pressure (nominal)		3.43 bar (49.7 lb/in ²)
Fuel		Trident 800
Fuel type		Unleaded, 91 RON (U.S. 87 CLC/AKI)
Fuel tank capacity		3.7 gallons (14.0 liters)
Low fuel indicator light		0.9 gallons (3.4 liters)

Ignition	Trident 800
Ignition system	Digital inductive
Electronic rev. limiter	11,500 rpm
Spark plug type	NGK CR9EK
Spark plug gap	0.02 - 0.03 in (0.60-0.75 mm)

Transmission	Trident 800
Transmission type	6 speed, constant mesh
Clutch type	Wet multi-plate, slip assist
Chain type	DID520VM4
Number of links	118
Chain length (20 links)	12.56 in (319 mm)
Primary drive ratio	1.854:1 (76/41)
Final drive ratio	3.188:1 (51/16)
Gear ratios - 1st gear	2.867:1 (43/15)
Gear ratios - 2nd gear	2.053:1 (39/19)
Gear ratios - 3rd gear	1.565:1 (36/23)
Gear ratios - 4th gear	1.286:1 (27/21)
Gear ratios - 5th gear	1.107:1 (31/28)
Gear ratios - 6th gear	0.967:1 (29/30)

WARNING

Use the recommended tires **ONLY** in the combinations listed in the approved Tire Selector at www.triumphtechnicalinformation.com/tyres.

Do not mix tires from different manufacturers or mix different specification tires from the same manufacturers.

Using/mixing tires may affect the handling, stability, braking and traction control (if equipped) functions of the motorcycle.

Failure to follow the advice above may lead to loss of motorcycle control, which could result in serious injury or death.

SPECIFICATIONS

Approved Tires

A list of approved tires specific to these models is available from your authorized Triumph dealer, or on the Internet at www.triumphtechnicalinformation.com/tyres.

Tires

Trident 800

Tire Sizes:

Front tire size	120/70 ZR17 58W
Rear tire size	180/55 ZR17 73W
Tire Pressures (Cold):	
Front tire pressure	33.9 lb/in ² (2.34 bar)
Rear tire pressure	42 lb/in ² (2.90 bar)

Electrical Equipment

Trident 800

Battery type	YTX9-BS
Battery rating	12 Volt - 8 Ah
Alternator rating	14 Volt, 31 Amp at 5,000 rpm
Parking light	LED
Headlight	LED
Rear/brake light	LED
License plate light	LED
Turn signal lights	LED

Torque Figures	Trident 800
Battery terminal fasteners	40 lbf in (4.5 Nm)
Drive chain slack adjuster lock nut	12 lbf ft (16 Nm)
Rear hugger and chain guard molding	35 lbf in (4 Nm)
Clutch cable lower lock nut	27 lbf in (3 Nm)
Oil filter	89 lbf in (10 Nm)
Spark plug	9 lbf ft (12 Nm)
Sump plug	18 lbf ft (25 Nm)
Rear wheel spindle lock nut	81 lbf ft (110 Nm)

Fluids and Lubricants	Trident 800
Bearings and pivots	Triumph Performance RG2 grease (NLGI 2)
Brake fluid	Triumph Performance DOT 4 brake fluid
Coolant	Triumph D2053 OAT coolant (premixed)
Drive chain	Triumph Performance chain lubricant
Engine oil	Fully or semi-synthetic 10W/40 or 10W/50 motorcycle engine oil that meets specification API SN (or higher) and JASO MA2. Triumph Performance fully synthetic engine oil is recommended

SPECIFICATIONS

Tiger Sport 660

Dimensions, Weights and Performance

A list of model specific dimensions, weights and performance figures is available from your authorized Triumph dealer, or on the Internet at www.triumphmotorcycles.co.uk.

Payload

Tiger Sport 660

Maximum payload (rider, passenger, luggage and accessories)

492 lb (223 kg)

Engine

Tiger Sport 660

Engine configuration

3 cylinder 12 valve DOHC

Arrangement

Transverse in-line

Displacement

40.3 cu in (660 cc)

Bore x stroke

2.91 x 2.01 in (74 x 51.1 mm)

Compression ratio

11.95:1

Cylinder numbering

Left to right (no.3 adjacent to camshaft drive)

Cylinder sequence

Number 1 at left

Firing order

1 2 3

Starting system

Electric starter

Lubrication

Tiger Sport 660

Lubrication system

Pressure lubrication, wet sump

Engine Oil Capacities:

Oil capacity (dry fill)

0.85 gallons (3.20 liters)

Oil capacity (wet fill including oil filter)

0.74 gallons (2.80 liters)

Oil capacity (wet fill excluding oil filter)

0.69 gallons (2.60 liters)

Cooling System	Tiger Sport 660
Coolant type	Triumph D2053 OAT coolant (premixed)
Coolant ratio	50/50 (premixed as supplied by Triumph)
Cooling system capacity	0.58 gallons (2.2 liters)
Thermostat opening temperature (nominal)	159.8°F +/- 4°F (71°C +/- 2°C)

Fuel System	Tiger Sport 660
Fuel injection system	Electronic, sequential
Injector type	Twin jet, solenoid operated plate valve
Fuel pump type	Submerged electric
Fuel pressure (nominal)	50.8 lb/in ² (3.5 bar)

Fuel	Tiger Sport 660
Fuel type	Unleaded, 91 RON (U.S. 87 CLC/AKI)
Fuel tank capacity	4.49 gallons (17.0 liters)
Low fuel indicator light	0.82 gallons (3.1 liters)

Ignition	Tiger Sport 660
Ignition system	Digital inductive
Electronic rev. limiter	10,500 rpm
Spark plug type	NGK CR9EK
Spark plug gap	0.02 - 0.03 in (0.60-0.75 mm)

SPECIFICATIONS

Transmission	Tiger Sport 660
Transmission type	6 speed, constant mesh
Clutch type	Wet multi-plate, slip assist
Chain type	DID520VM4
Number of links	122
Chain length (20 links)	12.56 in (319 mm)
Primary drive ratio	1.854:1 (76/41)
Final drive ratio	3.188:1 (51/16)
Gear ratios - 1st gear	2.867:1 (43/15)
Gear ratios - 2nd gear	2.053:1 (39/19)
Gear ratios - 3rd gear	1.565:1 (36/23)
Gear ratios - 4th gear	1.286:1 (27/21)
Gear ratios - 5th gear	1.107:1 (31/28)
Gear ratios - 6th gear	0.967:1 (29/30)

WARNING

Use the recommended tires **ONLY** in the combinations listed in the approved Tire Selector at www.triumphtechnicalinformation.com/tyres.

Do not mix tires from different manufacturers or mix different specification tires from the same manufacturers.

Using/mixing tires may affect the handling, stability, braking and traction control (if equipped) functions of the motorcycle.

Failure to follow the advice above may lead to loss of motorcycle control, which could result in serious injury or death.

Approved Tires

A list of approved tires specific to these models is available from your authorized Triumph dealer, or on the Internet at www.triumphtechnicalinformation.com/tyres.

Tires	
Tiger Sport 660	
Tire Sizes:	
Front tire size	120/70 ZR17 58W
Rear tire size	180/55 ZR17 73W
Tire Pressures (Cold):	
Front tire pressure	33 lb/in ² (2.28 bar)
Rear tire pressure	36 lb/in ² (2.48 bar)

Electrical Equipment	
Tiger Sport 660	
Battery type	YTX9-BS
Battery rating	12 Volt - 8 Ah
Alternator rating	14 Volt, 29 Amp at 5,000 rpm
Parking light	LED
Headlight	LED
Rear/brake light	LED
License plate light	LED
Turn signal lights	LED

SPECIFICATIONS

Torque Figures	Tiger Sport 660
Battery terminal fasteners	40 lbf in (4.5 Nm)
Drive chain slack adjuster lock nut	12 lbf ft (16 Nm)
Rear hugger and chain guard molding	35 lbf in (4 Nm)
Clutch cable lower lock nut	27 lbf in (3 Nm)
Oil filter	89 lbf in (10 Nm)
Spark plug	9 lbf ft (12 Nm)
Sump plug	18 lbf ft (25 Nm)
Rear wheel spindle lock nut	81 lbf ft (110 Nm)

Fluids and Lubricants	Tiger Sport 660
Bearings and pivots	Triumph Performance RG2 grease (NLGI 2)
Brake fluid	Triumph Performance DOT 4 brake fluid
Coolant	Triumph D2053 OAT coolant (premixed)
Drive chain	Triumph Performance chain lubricant
Engine oil	Fully or semi-synthetic 10W/40 or 10W/50 motorcycle engine oil that meets specification API SN (or higher) and JASO MA2. Triumph Performance fully synthetic engine oil is recommended

Tiger Sport 800

Dimensions, Weights and Performance

A list of model specific dimensions, weights and performance figures is available from your authorized Triumph dealer, or on the Internet at www.triumphmotorcycles.co.uk.

Payload

Tiger Sport 800

Maximum payload (rider, passenger, luggage and accessories)

489 lb (222 kg)

Engine

Tiger Sport 800

Engine configuration

3 cylinder 12 valve DOHC

Arrangement

Transverse in-line

Displacement

48.7 cu in (798 cc)

Bore x stroke

3.07 x 2.19 in (78 x 55.65 mm)

Compression ratio

13.23:1

Cylinder numbering

Left to right (no.3 adjacent to camshaft drive)

Cylinder sequence

Number 1 at left

Firing order

1 2 3

Starting system

Electric starter

Lubrication

Tiger Sport 800

Lubrication system

Pressure lubrication, wet sump

Engine Oil Capacities:

Oil capacity (dry fill)

0.9 gallons (3.40 liters)

Oil capacity (wet fill including oil filter)

0.79 gallon (3.00 liters)

Oil capacity (wet fill excluding oil filter)

0.74 gallons (2.80 liters)

SPECIFICATIONS

Cooling System	Tiger Sport 800
Coolant type	Triumph D2053 OAT coolant (premixed)
Coolant ratio	50/50 (premixed as supplied by Triumph)
Cooling system capacity	0.69 gallons (2.60 liters)
Thermostat opening temperature (nominal)	159.8°F +/- 4°F (71°C +/- 2°C)

Fuel System	Tiger Sport 800
Fuel injection system	Electronic, sequential
Injector type	Twin jet, solenoid operated plate valve
Fuel pump type	Submerged electric
Fuel pressure (nominal)	49.7 lb/in ² (3.43 bar)

Fuel	Tiger Sport 800
Fuel type	Unleaded, 91 RON (U.S. 87 CLC/AKI)
Fuel tank capacity	4.91 gallons (18.6 liters)
Low fuel indicator light	0.82 gallons (3.1 liters)

Ignition	Tiger Sport 800
Ignition system	Digital inductive
Electronic rev. limiter	11,350 rpm
Spark plug type	NGK CR9EK
Spark plug gap	0.02 - 0.03 in (0.60-0.75 mm)

Transmission	Tiger Sport 800
Transmission type	6 speed, constant mesh
Clutch type	Wet multi-plate, slip assist
Chain type	DID520VM4
Number of links	120
Chain length (20 links)	12.4 in (315 mm)
Primary drive ratio	1.848:1 (85/46)
Final drive ratio	3:1 (48/16)
Gear ratios - 1st gear	2.31:1 (37/16)
Gear ratios - 2nd gear	1.86:1 (39/21)
Gear ratios - 3rd gear	1.50:1 (36/24)
Gear ratios - 4th gear	1.29:1 (27/21)
Gear ratios - 5th gear	1.14:1 (25/22)
Gear ratios - 6th gear	0.97:1 (29/30)

WARNING

Use the recommended tires **ONLY** in the combinations listed in the approved Tire Selector at www.triumphtechnicalinformation.com/tyres.

Do not mix tires from different manufacturers or mix different specification tires from the same manufacturers.

Using/mixing tires may affect the handling, stability, braking and traction control (if equipped) functions of the motorcycle.

Failure to follow the advice above may lead to loss of motorcycle control, which could result in serious injury or death.

Approved Tires

A list of approved tires specific to these models is available from your authorized Triumph dealer, or on the Internet at www.triumphtechnicalinformation.com/tyres.

SPECIFICATIONS

Tires		Tiger Sport 800
Tire Sizes:		
Front tire size	120/70 ZR17 58W	
Rear tire size	180/55 ZR17 73W	
Tire Pressures (Cold):		
Front tire pressure	33 lb/in ² (2.28 bar)	
Rear tire pressure	36 lb/in ² (2.48 bar)	
Electrical Equipment		Tiger Sport 800
Battery type	YTX9-BS	
Battery rating	12 Volt - 8 Ah	
Alternator rating	14 Volt, 31 Amp at 6,000 rpm	
Parking light	LED	
Headlight	LED	
Rear/brake light	LED	
License plate light	LED	
Turn signal lights	LED	

Torque Figures	Tiger Sport 800
Battery terminal fasteners	40 lbf in (4.5 Nm)
Drive chain slack adjuster lock nut	12 lbf ft (16 Nm)
Rear hugger and chain guard molding	35 lbf in (4 Nm)
Clutch cable lower lock nut	27 lbf in (3 Nm)
Oil filter	89 lbf in (10 Nm)
Spark plug	9 lbf ft (12 Nm)
Sump plug	18 lbf ft (25 Nm)
Rear wheel spindle lock nut	81 lbf ft (110 Nm)

Fluids and Lubricants	Tiger Sport 800
Bearings and pivots	Triumph Performance RG2 grease (NLGI 2)
Brake fluid	Triumph Performance DOT 4 brake fluid
Coolant	Triumph D2053 OAT coolant (premixed)
Drive chain	Triumph Performance chain lubricant
Engine oil	Fully or semi-synthetic 10W/40 or 10W/50 motorcycle engine oil that meets specification API SN (or higher) and JASO MA2. Triumph Performance fully synthetic engine oil is recommended

Daytona 660

Dimensions, Weights and Performance

A list of model specific dimensions, weights and performance figures is available from your authorized Triumph dealer, or on the Internet at www.triumphmotorcycles.co.uk.

Payload**Daytona 660**

Maximum payload (rider, passenger, luggage and accessories)

430 lb (195 kg)

Engine**Daytona 660**

Engine configuration

3 cylinder 12 valve DOHC

Arrangement

Transverse in-line

Displacement

40.3 cu in (660 cc)

Bore x stroke

2.91 x 2.01 in (74 x 51.1 mm)

Compression ratio

12.05:1

Cylinder numbering

Left to right (no.3 adjacent to camshaft drive)

Cylinder sequence

Number 1 at left

Firing order

1 2 3

Starting system

Electric starter

Lubrication**Daytona 660**

Lubrication system

Pressure lubrication, wet sump

Engine Oil Capacities:

Oil capacity (dry fill)

0.97 gallons (3.70 liters)

Oil capacity (wet fill including oil filter)

0.84 gallons (3.20 liters)

Oil capacity (wet fill excluding oil filter)

0.79 gallons (3.0 liters)

Cooling System	Daytona 660
Coolant type	Triumph D2053 OAT coolant (premixed)
Coolant ratio	50/50 (premixed as supplied by Triumph)
Cooling system capacity	0.58 gallons (2.2 liters)
Cooling system capacity	159.8°F +/- 4°F (71°C +/- 2°C)

Fuel System	Daytona 660
Fuel injection system	Electronic, sequential
Injector type	Twin jet, solenoid operated plate valve
Fuel pump type	Submerged electric
Fuel pressure (nominal)	50.8 lb/in ² (3.5 bar)

Fuel	Daytona 660
Fuel type	Unleaded, 91 RON (U.S. 87 CLC/AKI)
Fuel tank capacity	3.7 gallons (14.0 liters)
Low fuel indicator light	0.82 gallons (3.1 liters)

Ignition	Daytona 660
Ignition system	Digital inductive
Electronic rev. limiter	12,650 rpm
Spark plug type	NGK CR9EK
Spark plug gap	0.02 - 0.03 in (0.60-0.75 mm)

Transmission	Daytona 660
Transmission type	6 speed, constant mesh
Clutch type	Wet multi-plate, slip assist
Chain type	DID520VM4
Number of links	120
Chain length (20 links)	12.56 in (319 mm)
Primary drive ratio	1.854:1 (76/41)
Final drive ratio	3.40:1 (51/15)
Gear ratios - 1st gear	2.31:1 (37/16)
Gear ratios - 2nd gear	1.86:1 (39/21)
Gear ratios - 3rd gear	1.50:1 (36/24)
Gear ratios - 4th gear	1.29:1 (27/21)
Gear ratios - 5th gear	1.14:1 (25/22)
Gear ratios - 6th gear	1.04:1 (24/23)

WARNING

Use the recommended tires **ONLY** in the combinations listed in the approved Tire Selector at www.triumphtechnicalinformation.com/tyres.

Do not mix tires from different manufacturers or mix different specification tires from the same manufacturers.

Using/mixing tires may affect the handling, stability, braking and traction control (if equipped) functions of the motorcycle.

Failure to follow the advice above may lead to loss of motorcycle control, which could result in serious injury or death.

Approved Tires

A list of approved tires specific to these models is available from your authorized Triumph dealer, or on the Internet at www.triumphtechnicalinformation.com/tyres.

Tires		Daytona 660
Tire Sizes:		
Front tire size		120/70 ZR17 58W
Rear tire size		180/55 ZR17 73W
Tire Pressures (Cold):		
Front tire pressure		34 lb/in ² (2.34 bar)
Rear tire pressure		42 lb/in ² (2.90 bar)
Electrical Equipment		Daytona 660
Battery type		YTX9-BS
Battery rating		12 Volt - 8 Ah
Alternator rating		14 Volt, 29 Amp at 5,000 rpm
Parking light		LED
Headlight		LED
Rear/brake light		LED
License plate light		LED
Turn signal lights		LED

SPECIFICATIONS

Torque Figures	Daytona 660
Battery terminal fasteners	40 lbf in (4.5 Nm)
Drive chain adjuster nut	27 lbf in (3 Nm)
Drive chain slack adjuster lock nut	11 lbf ft (15 Nm)
Rear hugger and chain guard molding	35 lbf in (4 Nm)
Clutch cable lower lock nut	27 lbf in (3 Nm)
Oil filter	89 lbf in (10 Nm)
Spark plug	9 lbf ft (12 Nm)
Sump plug	18 lbf ft (25 Nm)
Rear wheel spindle lock nut	81 lbf ft (110 Nm)
Rider seat fasteners	44 lbf in (5 Nm)

Fluids and Lubricants	Daytona 660
Bearings and pivots	Triumph Performance RG2 grease (NLGI 2)
Brake fluid	Triumph Performance DOT 4 brake fluid
Coolant	Triumph D2053 OAT coolant (premixed)
Drive chain	Triumph Performance chain lubricant
Engine oil	Fully or semi-synthetic 10W/40 or 10W/50 motorcycle engine oil that meets specification API SN (or higher) and JASO MA2. Triumph Performance fully synthetic engine oil is recommended

Tiger Sport 800 Tour

Dimensions, Weights and Performance

A list of model specific dimensions, weights and performance figures is available from your authorized Triumph dealer, or on the Internet at www.triumphmotorcycles.co.uk.

Payload Tiger Sport 800 Tour

Maximum payload (rider, passenger, luggage and accessories)	447 lb (203 kg)
---	-----------------

Engine Tiger Sport 800 Tour

Engine configuration	3 cylinder 12 valve DOHC
Arrangement	Transverse in-line
Displacement	48.8 cu in (800 cc)
Bore x stroke	3.07 x 2.19 in (78 x 55.65 mm)
Compression ratio	13.23:1
Cylinder numbering	Left to right (no.3 adjacent to camshaft drive)
Cylinder sequence	Number 1 at left
Firing order	1 2 3
Starting system	Electric starter

Lubrication Tiger Sport 800 Tour

Lubrication system	Pressure lubrication, wet sump
--------------------	--------------------------------

Engine Oil Capacities:

Oil capacity (dry fill)	0.9 gallons (3.40 liters)
Oil capacity (wet fill including oil filter)	0.79 gallons (3.00 liters)
Oil capacity (wet fill excluding oil filter)	0.74 gallons (2.80 liters)

SPECIFICATIONS

Cooling System	Tiger Sport 800 Tour
Coolant type	Triumph D2053 OAT coolant (premixed)
Coolant ratio	50/50 (premixed as supplied by Triumph)
Cooling system capacity	0.69 gallons (2.60 liters)
Thermostat opening temperature (nominal)	159.8°F +/- 4°F (71°C +/- 2°C)

Fuel System	Tiger Sport 800 Tour
Fuel injection system	Electronic, sequential
Injector type	Twin jet, solenoid operated plate valve
Fuel pump type	Submerged electric
Fuel pressure (nominal)	49.7 lb/in ² (3.43 bar)

Fuel	Tiger Sport 800 Tour
Fuel type	Unleaded, 91 RON (U.S. 87 CLC/AKI)
Fuel tank capacity	4.91 gallons (18.6 liters)
Low fuel indicator light	0.82 gallons (3.1 liters)

Ignition	Tiger Sport 800 Tour
Ignition system	Digital inductive
Electronic rev. limiter	11,500 rpm
Spark plug type	NGK CR9EK
Spark plug gap	0.024 x 0.03 in (0.60-0.75 mm)

Transmission	Tiger Sport 800 Tour
Transmission type	6 speed, constant mesh
Clutch type	Wet multi-plate, slip assist
Chain type	DID520VM4
Number of links	120
Chain length (20 links)	12.56 in (319 mm)
Primary drive ratio	1.848:1 (85/46)
Final drive ratio	3:1 (48/16)
Gear ratios - 1st gear	2.31:1 (37/16)
Gear ratios - 2nd gear	1.86:1 (39/21)
Gear ratios - 3rd gear	1.50:1 (36/24)
Gear ratios - 4th gear	1.29:1 (27/21)
Gear ratios - 5th gear	1.14:1 (25/22)
Gear ratios - 6th gear	0.97:1 (29/30)

WARNING

Use the recommended tires **ONLY** in the combinations listed in the approved Tire Selector at www.triumphtechnicalinformation.com/tyres.

Do not mix tires from different manufacturers or mix different specification tires from the same manufacturers.

Using/mixing tires may affect the handling, stability, braking and traction control (if equipped) functions of the motorcycle.

Failure to follow the advice above may lead to loss of motorcycle control, which could result in serious injury or death.

Approved Tires

A list of approved tires specific to these models is available from your authorized Triumph dealer, or on the Internet at www.triumphtechnicalinformation.com/tyres.

SPECIFICATIONS

Tires		Tiger Sport 800 Tour
Tire Sizes:		
Front tire size	120/70 ZR17 58W	
Rear tire size	180/55 ZR17 73W	
Tire Pressures (Cold):		
Front tire pressure	33 lb/in ² (2.28 bar)	
Rear tire pressure	36 lb/in ² (2.48 bar)	
Electrical Equipment		Tiger Sport 800 Tour
Battery type	YTX9-BS	
Battery rating	12 Volt - 8 Ah	
Alternator rating	14 Volt, 31 Amp at 6,000 rpm	
Parking light	LED	
Headlight	LED	
Rear/brake light	LED	
License plate light	LED	
Turn signal lights	LED	

Torque Figures	Tiger Sport 800 Tour
Battery terminal fasteners	40 lbf in (4.5 Nm)
Drive chain slack adjuster lock nut	12 lbf ft (16 Nm)
Rear hugger and chain guard molding	35 lbf in (4 Nm)
Clutch cable lower lock nut	27 lbf in (3 Nm)
Oil filter	7 lbf ft (10 Nm)
Spark plug	9 lbf ft (12 Nm)
Sump plug	18 lbf ft (25 Nm)
Rear wheel spindle lock nut	81 lbf ft (110 Nm)

Fluids and Lubricants	Tiger Sport 800 Tour
Bearings and pivots	Triumph Performance RG2 grease (NLGI 2)
Brake fluid	Triumph Performance DOT 4 brake fluid
Coolant	Triumph D2053 OAT coolant (premixed)
Drive chain	Triumph Performance chain lubricant
Engine oil	Fully or semi-synthetic 10W/40 or 10W/50 motorcycle engine oil that meets specification API SN (or higher) and JASO MA2. Triumph Performance fully synthetic engine oil is recommended

This page intentionally left blank

A	
Accessories, Loading and Passengers	159
Accessories	159
Loading.....	161
Passengers.....	162
Ambient Air Temperature	70
Anti-lock Braking System (ABS)	153
Optimized Cornering ABS.....	154
Warning Light.....	153
B	
Bank Angle Indicators	215
Battery	221
Charging.....	225
Discharge.....	225
Disposal	224
Installation.....	226
Maintenance	224
Removal.....	222
Storage.....	225
Belly Pan	
Installation.....	175
Removal.....	174
Bluetooth®	92
Brakes.....	195
Braking	151
Breaking-in New Brake Discs and Pads..	195
Disc Brake Fluid.....	198
Front Brake Fluid Adjustment	199
Front Brake Fluid Inspection.....	199
Front Brake Wear Inspection.....	196
Light Switches	201
Optimized Cornering ABS.....	154
Pad Wear Compensation.....	195
Rear Brake Fluid Adjustment.....	201
Rear Brake Fluid Inspection.....	200
Rear Brake Wear Inspection	197
Breaking-In.....	142
Brightness	78
C	
Cleaning	
After Washing.....	244
Aluminum Items - not Lacquered or Painted	245
Black Chrome Items.....	246
Care of Leather Products	249
Chrome and Stainless Steel.....	246
Exhaust System	247
Frequency of Cleaning	242
Gloss Paintwork.....	245
Matt Paintwork.....	245
Monsoon.....	250
Preparation for Washing.....	242
Seat Care	248
Washing.....	244
Where to be Careful	243
Windshield.....	249
Cleaning and Storage	242
Clutch	186
Adjustment	187
Inspection.....	186
Controls	
Brake Lever Adjuster	98
Clutch Lever	98
Engine Immobilizer	98
Heated Grips Button (if equipped)	103
Ignition Key.....	97
Ignition Switch/Steering Lock.....	96
Left Handlebar Switches	100
Right Handlebar Switches.....	99
Throttle Control	95
Coolant.....	77
Coolant Temperature Gage	69
Cooling System	181
Coolant Change.....	184
Coolant Level Adjustment.....	183
Coolant Level Inspection	182
Corrosion Inhibitors	181
Radiator and Hoses.....	185

- Cruise Control 108
 - Activating..... 108
 - Deactivating 108
- D**
- Daytime Running Lights (DRL) 63
- Drive Chain 188
 - Damage Inspection..... 191
 - Free Movement Adjustment 190
 - Free Movement Inspection..... 189
 - Lubrication..... 188
 - Sprockets Wear Inspection 193
 - Wear Inspection 192
- E**
- Engine
 - Moving Off 148
 - Starting the Engine..... 147
 - Stopping the Engine..... 146
- Engine Oil 174
 - Oil and Oil Filter Change..... 178
 - Oil Level Inspection..... 177
 - Specification and Grade 180
- Engine Start/Stop Switch
 - RUN Position 99
 - START Position 99
 - STOP Position 99
- F**
- Fairings..... 120
 - Installation..... 123
 - Removal..... 120
- Final Drive Chain Guard
 - Installation..... 194
 - Removal..... 193
- Front Fork Inspection 207
- Fuel
 - Filling the Fuel Tank..... 107
 - Fuel Gage 68
 - Fuel Grade..... 104
 - Fuel Tank Cap..... 106
 - Refueling 106
- Fuel Status..... 76
- Fuses..... 229
 - Identification 232
- G**
- Gears 79
 - Gear Position 71
 - Shifting Gears 149
- H**
- Handbook and Tool Kit
 - Handbook 141
 - Tool Kit 141
- Headlight(s)..... 237
 - Adjustment 238
 - Condensation 238
 - Replacement..... 240
- High Speed Operation 157
- I**
- Instruments
 - Ambient Air Temperature..... 70
 - Bike Set Up Menu..... 83
 - Bike Setup - Service 85
 - Bike Setup - Traction Control (TC)..... 84
 - Bike Setup - TSA (if equipped) 83
 - Bike Setup - Turn Signals..... 84
 - Bluetooth® 92
 - Brightness..... 78

Coolant	77
Coolant Temperature Gage.....	69
Daytona 660	57
Display Navigation.....	71
Display Setup - Brightness	87
Display Setup - Clock	90
Display Setup - Date	91
Display Setup - Language	89
Display Setup - Shift Indicator	88
Display Setup - Units.....	89
Display Setup - Visible Trays.....	88
Display Setup Menu	87
Frost Symbol.....	70
Fuel Gage	68
Fuel Status	76
Gear Position.....	71
Gears.....	79
Information Tray	75
Main Menu.....	80
Odometer	67
Reset to Defaults.....	92
Riding Mode Configuration	82
Riding Modes	72, 81
Service Interval.....	78
Speedometer.....	67
Tachometer.....	68, 79
Tiger Sport 660	55
Tiger Sport 800	56
Tire Pressure Monitoring System (TPMS) (if equipped)	77
Trident 660 and Trident 660 - Triple Tribute	53
Trident 800.....	54
Trip 2 Display.....	87
Trip Meters	76
Trip Setup - Automatic Reset	86
Trip Setup - Manual Reset.....	86
Trip Setup Menu.....	85
Warning and Information Messages.....	64
Warning Lights.....	58

L

Left Handlebar Switches	
Automatic Daytime Running Lights (DRL) Button (if equipped).....	102
Cruise Control Button (if equipped)	102
High Beam Button	101
Horn Button	101
Mode Button	101
Navigation Buttons.....	101
Turn Signal Switch	101
License Plate Light	240
Lights	237
Headlight(s).....	237
Headlight(s) Adjustment.....	238
Headlight(s) Replacement	240
License Plate Light	240
Tail Light	240
Turn Signal Lights	240
Luggage System	
Pannier Installation	129
Pannier Operation.....	126

M

Maintenance	
Scheduled Maintenance	168
Mirrors	
Bar End Mirrors.....	202
Mirror Adjustment	203

O

Odometer.....	67
---------------	----

P

Parking.....	156
Parts Identification	
..... 30, 31, 32, 33, 34, 35, 36, 37, 38, 39, 40, 41	
Rider View.....	42, 43, 44, 45, 46, 47

- R**
- Rider View..... 42, 43, 44, 45, 46, 47
 - Riding Modes
 - Configuration 82
 - Rain 72
 - Road 73
 - Selection 74
 - Sport 73
 - Right Handlebar Switches
 - Engine Start/Stop Switch - RUN Position 99
 - Engine Start/Stop Switch - START Position 99
 - Engine Start/Stop Switch - STOP Position 99
 - Hazard Warning Lights Button 99
- S**
- Safety
 - Daily Safety Checks 143
 - Fuel and Exhaust Fumes 10
 - Handlebars and Footrests 15
 - Helmet and Clothing 11
 - Maintenance and Equipment 12
 - Parking 13
 - Parts and Accessories 17
 - Riding 13
 - The Motorcycle 09
 - Scheduled Maintenance
 - Disposal of Used Fluids 169
 - Seats 115
 - Seat Care 115, 248
 - Seat Installation 117
 - Seat Lock 115
 - Seat Removal 116
 - Serial Numbers
 - Engine Serial Number 49
 - Vehicle Identification Number 49
 - Service Interval 78
 - Specifications
 - Cooling System . 269, 274, 279, 284, 289, 294
 - Daytona 660 288
 - Electrical Equipment 271, 276, 281, 286, 291, 296
 - Engine 268, 273, 278, 283, 288, 293
 - Fluids and Lubricants 272, 277, 282, 287, 292, 297
 - Fuel 269, 274, 279, 284, 289, 294
 - Fuel System 269, 274, 279, 284, 289, 294
 - Ignition 269, 275, 279, 284, 289, 294
 - Lubrication 268, 274, 278, 283, 288, 293
 - Payload 268, 273, 278, 283, 288, 293
 - Tiger Sport 800 283
 - Tiger Sport 800 Tour 293
 - Tiger Sport 660 278
 - Tires 271, 276, 281, 286, 291, 296
 - Torque Figures... 272, 277, 282, 287, 292, 297
 - Transmission 270, 275, 280, 285, 290, 295
 - Trident 660 and Trident 660 - Triple Tribute 268
 - Trident 800 273
 - Speedometer 67
 - Stands 113
 - Center Stand 114
 - Paddock Stand Pegs 115
 - Side Stand 114
 - Steering Bearings
 - Inspection 204
 - Steering/Wheel Bearings 204
 - Storage
 - Preparation after Storage 252
 - Preparation for Storage 251
 - Suspension 206
 - Front Compression Damping Adjustment 212
 - Front Rebound Damping Adjustment 211
 - Rear Rebound Damping Adjustment 214
 - Rear Spring Preload Adjustment 213
 - Suspension Settings 208

T	
Tachometer.....	68, 79
Tail Light.....	240
Throttle Control.....	185
Brake Use	95
Inspection	186
Tire Pressure Monitoring System (TPMS).....	111
Replacement Tires.....	113
Sensor Batteries	112
Sensor Serial Number	113
Tire Pressure Warning Light	63
Tire Pressures	112, 217
Tire Pressure Monitoring System (TPMS) (if equipped)	77
Tires	216
Minimum Tread Depth	218
Replacement	113, 218
Tire Inflation Pressures.....	217
Tire Type	216
Tire Wear	218
Traction Control (TC).....	109
Optimized Cornering Traction Control	109
Settings	110
Trip Meters	76
Triumph Shift Assist (TSA)	150
Turn Signal Lights.....	240
W	
Warning Lights	
Anti-lock Braking System (ABS) Warning Light	61
Cruise Control Indicator Light.....	61
Daytime Running Lights (DRL) (if equipped)	63
Engine Immobilizer / Alarm Indicator Light	60
Engine Management System Malfunction Indicator Light (MIL).....	58
General Warning Symbol.....	64
Hazard Warning Lights.....	62
High Beam Indicator Light.....	62
High Coolant Temperature Warning Light	59
Low Battery Warning Light.....	64
Low Fuel Indicator Light.....	63
Low Oil Pressure Warning Light.....	59
Neutral Indicator Light	63
Traction Control (TC) Disabled Warning Light	62
Traction Control (TC) Indicator Light	62
Turn signal Light	62
Warnings.....	05
Immobilizer and TPMS.....	304
Maintenance.....	06
Noise Control System.....	06
Owner's Handbook.....	03
QR Code	04
Talk to Triumph	07
Triumph Technical Information (TTI).....	04
Warning Label Locations	18, 19, 20, 21, 22, 23, 24, 25, 26, 27, 28, 29
Warning Labels	05
Warning Lights	58
Wheel Bearings	
Inspection.....	205
Windshield.....	141
Adjustment	141
Cleaning	249

APPROVAL INFORMATION

This section contains approval information that is required to be included in this Owner's Handbook.

FCC Statement

This device complies with part 15 of the Federal Communications Commission (FCC) Rules.

Operation is subject to the following two conditions:

- ▼ This device may not cause harmful interference.
- ▼ This device must accept any interference received, including interference that may cause undesired operation.

Changes or modifications to the device could void the user's authority to operate the equipment.

Canadian Approval

This device contains license-exempt transmitter(s)/receiver(s) that comply with Innovation, Science and Economic Development Canada's license-exempt RSS(s).

Operation is subject to the following two conditions:

1. This device may not cause interference.
2. This device must accept any interference, including interference that may cause undesired operation of the device.

Radio frequency radiation exposure information:

This equipment complies with radiation exposure limits set forth for an uncontrolled environment. This equipment should be installed and operated with minimum distance of 20 cm between the radiator and your body.